

# ON THE GAUSS HYPERGEOMETRIC SERIES WITH ROOTS OUTSIDE THE UNIT DISK

高野勝男 茨城大 [Takano Katsuo, Ibaraki University]  
岡崎宏光 熊本大 [Okazaki Hiromitsu, Kumamoto University]

## 1. Introduction

It is known in [10] that the normed conjugate product of gamma functions such as

$$\frac{2}{\pi} \Gamma(1 - ix) \Gamma(1 + ix) = \frac{2}{\pi} \frac{1}{\prod_{n=1}^{\infty} (1 + x^2/n^2)}, \quad (1)$$

is an infinitely divisible density. In the process in showing the infinite divisibility of the probability distribution with density (1), a family of polynomials with roots outside the unit disk appeared. From the infinite divisibility of the above probability distribution and from numerical analysis of roots of the terminating hypergeometric series we conjectured that the following density function consisting of normed conjugate product of gamma functions is an infinitely divisible density.

$$c \left| \frac{\Gamma(m + ix)}{\Gamma(m)} \right|^2 = \frac{c}{\prod_{n=0}^{\infty} (1 + x^2/(m + n)^2)} \quad (m \in N) \quad (2)$$

(cf. [1. 6.1.25]) In this case the Gauss hypergeometric series, i.e.,  ${}_2F_1(-n, 2m; 2m + n + 1; z)$  appears in general form and it is much more complicated than the case  $m = 1$ . We are necessary to study the location of roots of the Gauss hypergeometric series in showing the infinite divisibility of the probability distribution with density (2).

## 2. The hypergeometric series doesn't have roots on the unit circle

Let

$$g_n(z) = {}_2F_1(-n, 2m; 2m + n + 1; z).$$

It is often convenient for us to treat the polynomial  $z^m g_n(z)$  in stead of  $g_n(z)$ . Consider the unit circle  $C : z = e^{it}$  ( $0 \leq t \leq 2\pi$ ). Let

$$u(m, n; t) = \operatorname{Re} e^{imt} g_n(e^{it}),$$

$$v(m, n; t) = \operatorname{Im} e^{imt} g_n(e^{it}).$$

We have

$$\begin{aligned} u(m, n; t) &= \cos mt + \frac{(-n)(2m)}{2m+n+1} \cos(m+1)t \\ &+ \frac{(-n)_2(2m)_2}{(2m+n+1)_2} \frac{\cos(m+2)t}{2!} + \frac{(-n)_3(2m)_3}{(2m+n+1)_3} \frac{\cos(m+3)t}{3!} + \dots \\ &+ \frac{(-n)_k(2m)_k}{(2m+n+1)_k} \frac{\cos(m+k)t}{k!} + \dots \\ &+ \frac{(-n)_n(2m)_n}{(2m+n+1)_n} \frac{\cos(m+n)t}{n!} \end{aligned} \quad (3)$$

and

$$\begin{aligned} v(m, n; t) &= \sin mt + \frac{(-n)(2m)}{2m+n+1} \sin(m+1)t \\ &+ \frac{(-n)_2(2m)_2}{(2m+n+1)_2} \frac{\sin(m+2)t}{2!} + \frac{(-n)_3(2m)_3}{(2m+n+1)_3} \frac{\sin(m+3)t}{3!} + \dots \\ &+ \frac{(-n)_k(2m)_k}{(2m+n+1)_k} \frac{\sin(m+k)t}{k!} + \dots \\ &+ \frac{(-n)_n(2m)_n}{(2m+n+1)_n} \frac{\sin(m+n)t}{n!}. \end{aligned} \quad (4)$$

Here  $(a)_k = a(a+1)(a+2)\dots(a+k-1)$  denotes the Pochhammer symbol. We note that  $u(m, n; t)$  and  $v(m, n; t)$  do not always make a Jordan curve when  $t$  runs through the interval  $[0, 2\pi]$ . It is known in [1] that the Gauss hypergeometric series is a solution of a differential equation. That is,  $g_n(z)$  satisfies the hypergeometric equation.

$$z(1-z) \frac{d^2}{dz^2} g_n(z) + (2m+n+1 - (2m-n+1)z) \frac{d}{dz} g_n(z) + 2mng_n(z) = 0. \quad (5)$$

**Lemma 1** When  $1 \leq m$  and  $1 \leq n$  the functions  $u(m, n; t)$  and  $v(m, n; t)$  are solutions of the following differential equation

$$\sin \frac{t}{2} x''(t) - n \cos \frac{t}{2} x'(t) + (n+m)m \sin \frac{t}{2} x(t) = 0. \quad (6)$$

**Proof.** Let  $h(z) = z^m g_n(z)$ . Then we obtain the following differential equation

$$z^2(1-z)h''(z) + (n+1+(n-1)z)zh'(z) - (m+n)m(1-z)h(z) = 0. \quad (7)$$

If  $z = e^{it}$  we obtain the following equation

$$(1 - e^{it}) \frac{d^2 h(e^{it})}{dt^2} + n(1 + e^{it})i \frac{dh(e^{it})}{dt} + (n+m)m(1 - e^{it})h(e^{it}) = 0 \quad (8)$$

and hence we can see that the functions  $u(m, n; t)$  and  $v(m, n; t)$  are solutions of the following differential equation

$$\sin \frac{t}{2} x''(t) - n \cos \frac{t}{2} x'(t) + (n+m)m \sin \frac{t}{2} x(t) = 0.$$

q.e.d.

By using the above Lemma we can obtain the following result.

**Theorem 1.** *If  $1 \leq m$  and  $1 \leq n$  the Gauss hypergeometric series  $g_n(z)$  does not have roots on the unit circle.*

**Proof.** In order to show that  $z^m g_n(z)$  does not have roots on the unit circle we will show that the following relation

$$w(t) = u(m, n; t)v'(m, n; t) - u'(m, n; t)v(m, n; t) = c(1 - \cos t)^n \quad (9)$$

holds, where  $c$  is positive constant not depending on the variable  $t$ . If and only if  $t_0 = 0, 2\pi$  then  $w(t_0) = 0$ . But we have  $\cos(k+m)t_0 = 1$  and by Vandermode's formula  $u(m, n; t_0) = (n+1)_n / (2m+n+1)_n > 0$  and so  $v'(m, n; t_0) = 0$ . Let us set

$$\alpha(t) = 2^{-2n} \sin^{-2n} \left( \frac{t}{2} \right)$$

and

$$\beta(t) = 2^{-2n} (n+1) \sin^{-2n} \left( \frac{t}{2} \right).$$

Then the differential equation (6) can be written such as the following form,

$$\{\alpha(t)x'(t)\}' + \beta(t)x(t) = 0$$

and the wronskian  $w(t)$  can be expressed as the following form,

$$\alpha(t)w(t) = c \text{ (const).}$$

From the above differential equation we obtain

$$w(t) = \{\alpha(t)\}^{-1}c = c 2^{2n} \sin^{2n}\left(\frac{t}{2}\right).$$

To determine  $c$  we take  $t = \pi$ . Then it implies

$$w(\pi) = u(m, n; \pi)v'(m, n; \pi) - u'(m, n; \pi)v(m, n; \pi) = c 2^{2n}.$$

We see that if  $m$  is an even positive integer then

$$\begin{aligned} w(\pi) &= \left\{ 1 + \frac{(-n)(2m)}{2m+n+1}(-1) + \frac{(-n)_2(2m)_2}{(2m+n+1)_2} + \frac{(-n)_3(2m)_3}{(2m+n+1)_3} \frac{(-1)}{3!} + \dots \right. \\ &+ \left. \frac{(-n)_k(2m)_k}{(2m+n+1)_k} \frac{(-1)^k}{k!} + \dots + \frac{(-n)_n(2m)_n}{(2m+n+1)_n} \frac{(-1)^n}{n!} \right\} \\ &\cdot \left\{ m + \frac{(-n)(2m)}{2m+n+1}(m+1)(-1) + \frac{(-n)_2(2m)_2}{(2m+n+1)_2} \frac{(m+2)}{2!} \right. \\ &+ \frac{(-n)_3(2m)_3}{(2m+n+1)_3} \frac{(m+3)(-1)}{3!} + \dots \\ &+ \frac{(-n)_k(2m)_k}{(2m+n+1)_k} \frac{(m+k)(-1)^k}{k!} + \dots \\ &+ \left. \frac{(-n)_n(2m)_n}{(2m+n+1)_n} \frac{(m+n)(-1)^n}{n!} \right\} \end{aligned} \quad (10)$$

is positive and so  $c$  is positive constant. In the same way we see that if  $m$  is an odd integer then  $c$  is positive constant. q.e.d.

### 3. The hypergeometric series has roots outside the unit disk

If  $m = 1$  it is known in [9] that the roots of  $g_n(z)$  appears outside the closed unit disk. If  $n = 1$  the root of  $g_1(z)$  is  $z_1 = (m+1)/m$  and if  $n = 2$  the roots of  $g_2(z)$  are

$$z_1 = \frac{m+1}{2m+1} \left( \frac{m+2}{m+1} + i\sqrt{\frac{3(m+2)}{m}} \right), \quad z_2 = \frac{m+1}{2m+1} \left( \frac{m+2}{m+1} - i\sqrt{\frac{3(m+2)}{m}} \right)$$

for all  $m \in N$ . These roots are outside the unit disk. Concerning the roots of the Gauss hypergeometric function  $g_n(z)$  for  $n$  larger than 2 we obtain the following result.

**Theorem 2.** *If  $1 \leq m$  and  $1 \leq n$  the Gauss hypergeometric series  $g_n(z)$  has roots outside the unit disk.*

**Proof.** Let

$$p(-n, 2m; 2m + n + 1; t) = \operatorname{Re}\{ {}_2F_1(-n, 2m; 2m + n + 1; e^{it}) \}$$

and

$$q(-n, 2m; 2m + n + 1; t) = \operatorname{Im}\{ {}_2F_1(-n, 2m; 2m + n + 1; e^{it}) \}.$$

If  $t = 0$  then

$$p(-n, 2m; 2m + n + 1; 0) = \frac{(n+1)_n}{(2m+n+1)_n} = p(0) > 0$$

and

$$q'(-n, 2m; 2m + n + 1; 0) = -\frac{(2m)n}{2m+n+1} \frac{(n+1)_{n-1}}{(2m+n+2)_{n-1}} < 0.$$

If  $t = \pi$  then

$$p(-n, 2m; 2m + n + 1; \pi) = \sum_{k=0}^n \frac{(-n)_k (2m)_k (-1)^k}{(2m+n+1)_k k!} = p(\pi)$$

and  $p(0) < p(\pi)$ , and

$$q'(-n, 2m; 2m + n + 1; \pi) = \frac{(2m)n}{2m+n+1} \sum_{k=0}^{n-1} \frac{(-n+1)_k (2m+1)_k (-1)^k}{(2m+n+2)_k k!} > 0.$$

The closed interval  $[-1, 1]$  of real line is mapped to the interval  $[p(0), p(\pi)]$  of the real positive line by the function  $g_n(z)$ .  $g_n(e^{it})$  is symmetric on the interval  $[0, 2\pi]$ . In order to show that all the roots of the Gauss hypergeometric function  $g_n(z)$  are outside the unit disk, it suffices to show that  $|g_n(e^{it})|^2$  is strictly increasing in  $t$  on the interval  $[0, \pi]$ . It suffices to show that the derivative of the function  $|g_n(e^{it})|^2$  is positive in  $t$  on the interval  $(0, \pi)$ . We make use of the following formula

$$\begin{aligned} & {}_2F_1(-n, b; c; z) {}_2F_1(-n, b; c; Z) \\ &= \frac{(c-b)_n}{(c)_n} F_4[-n, b; c, 1-n+b-c; zZ, (1-z)(1-Z)] \end{aligned}$$

for  $z = e^{it}$ ,  $Z = e^{-it}$  and  $b = 2m$ ,  $c = 2m + n + 1$ , where

$$F_4[-n, b; c, 1 - n + b - c; zZ, (1 - z)(1 - Z)] \\ = \sum_{r=0}^n \sum_{s=0}^n \frac{(-n)_{r+s} (b)_{r+s} (zZ)^r [(1 - z)(1 - Z)]^s}{(c)_r (1 - n + b - c)_s r! s!}.$$

From the above we obtain

$$|g_n(e^{it})|^2 = \frac{(n+1)_n}{(2m+n+1)_n} \sum_{r=0}^n \sum_{s=0}^n \frac{(-n)_{r+s} (2m)_{r+s} [2y]^{2s}}{(2m+n+1)_r (-2n)_s r! s!},$$

where  $y$  denotes  $\sin(t/2)$ . By Vandermode's formula we see that

$$|g_n(e^{it})|^2 \\ = \sum_{s=0}^n \frac{(2m)_s}{(2m+n+1)_n (2m+n+1)_{n-s}} \binom{n}{s} \binom{2n-s}{n} (2(n-s))! [2y]^{2s}$$

Let us denote the derivative of  $|g_n(e^{it})|^2/2$  by  $d(t)$ . We can write  $d(t)$  such as the following form

$$d(t) = n \sin t \left[ A_0 + A_1 (2y)^2 + A_2 (2y)^4 + \dots + A_{n-2} (2y)^{2(n-2)} \right. \\ \left. + A_{n-1} (2y)^{2(n-1)} \right], \quad (11)$$

and the coefficient  $A_{n-j}$  is given by

$$A_{n-j} = \frac{(2m)_{n-j+1}}{(2m+n+1)_n (2m+n+1)_{j-1}} \binom{n-1}{n-j} \binom{n+j-1}{n} (2(j-1))! \quad (12)$$

for  $j = 1, 2, \dots, n$ . Since all the coefficients  $A_{n-j}$  are positive we see that the function  $d(t)$  is positive on the interval  $(0, \pi)$ .

q.e.d.

At last we mention of the computational result of the above theorem 3.1. The following curves which are images of the unit circle by the Gauss hypergeometric functions  $g_n(z)$  don't enclose the origin and these graphs show us that all the roots of  $g_n(z)$  are outside the unit disk. The notation 'log' in the label means that the curve is the image of the unit circle by  $g_n(z)$  and it is modified by a transformation of logarithm. The figure 13 is the curve of normal scale to contrast with the figure 14. The figure 15 is consisted of curves of images of the 5 circles with radii  $r = 1, 0.95, 0.90, 0.85, 0.80$ .

## References

- [1] M. Abramowitz and I. A. Stegun, Handbook of Mathematical Functions, New York, Dover, 1970.
- [2] L. Bondesson, On the infinite divisibility of the half-Cauchy and other decreasing densities and probability functions on the nonnegative line, *Scand. Actuarial J.*, (1985), 225-247.
- [3] E. Koelink and W. Van Assche, Orthogonal Polynomials and Special Functions, *Lecture Notes in Mathematics*, 1817 Leuven 2002, Springer 2003.
- [4] W. Koepf, Hypergeometric Summations, *Advanced Lecture in Mathematics*, Vieweg, Braunschweig/Wiesbaden, 1998.
- [5] M. J. Goovaerts, L. D'Hooge, and N. De Pril, On the infinite divisibility of the product of two  $\Gamma$ -distributed stochastic variables, *Applied mathematics and computation*, 3 (1977), 127-135.
- [6] K. Sato, Class  $L$  of multivariate distributions and its subclasses, *J. Multivariate Anal.* 10 (1980), 207-232.
- [7] L. J. Slater, Generalized hypergeometric functions, Cambridge University Press, 1966.
- [8] F. W. Steutel, Preservation of infinite divisibility under mixing and related topics, *Math. Centre Tracts, Math. Centre, Amsterdam*, 33. 1970
- [9] K. Takano, On a family of polynomials with zeros outside the unit disk, *International J. comput. Numer. Anal. Appl.*, 1. No.1 (2002), 369-382.
- [10] K. Takano, On infinite divisibility of normed product of Cauchy densities, *J. Comput. Applied Math.*, 150(2003), 253-263.

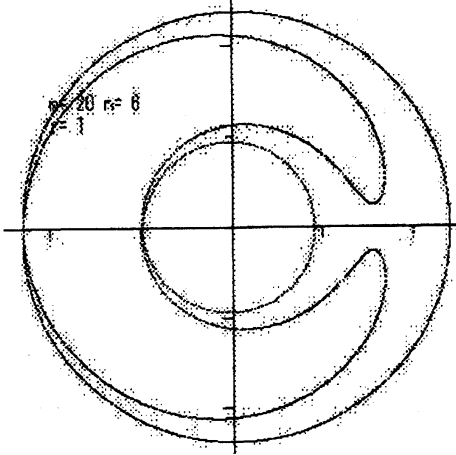
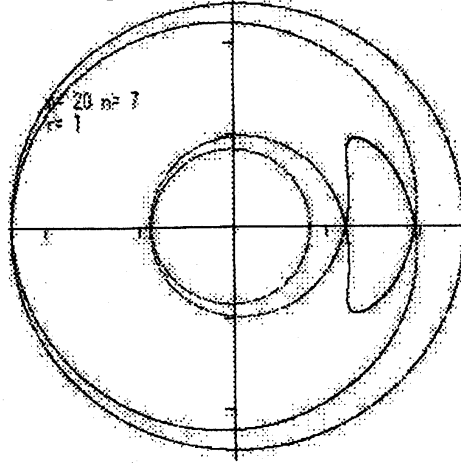
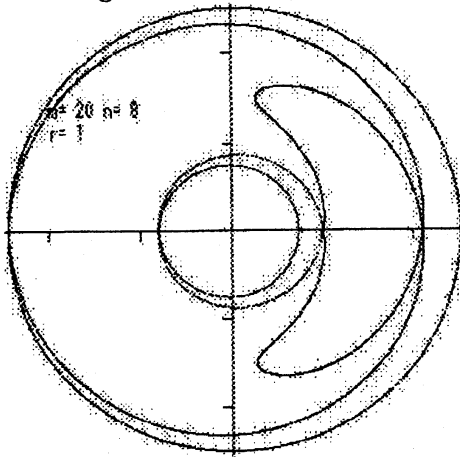
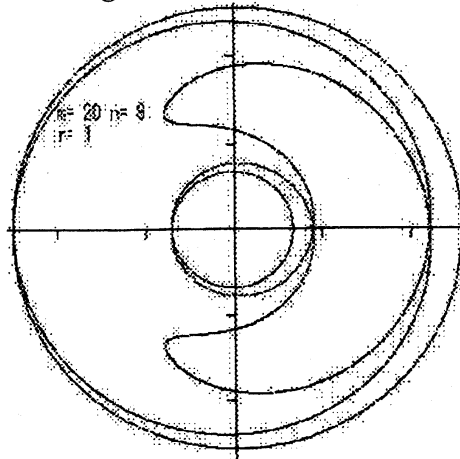
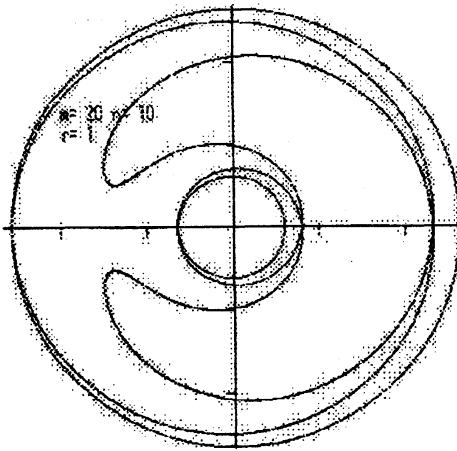
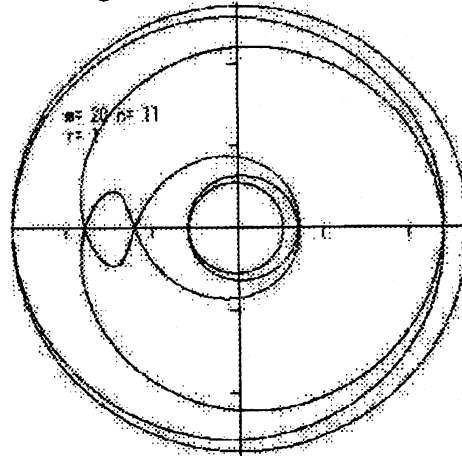
Figure 1:  $m=20, n=6$  logFigure 2:  $m=20, n=7$  logFigure 3:  $m=20, n=8$  logFigure 4:  $m=20, n=9$  logFigure 5:  $m=20, n=10$  logFigure 6:  $m=20, n=11$  log



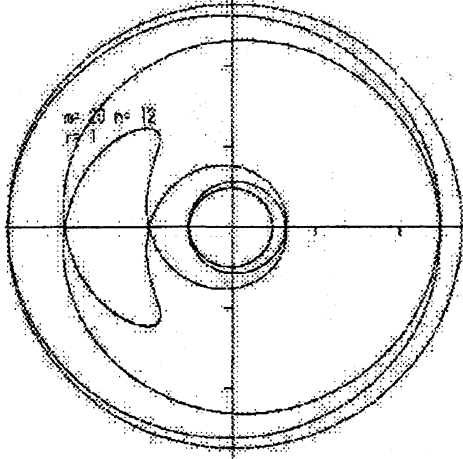
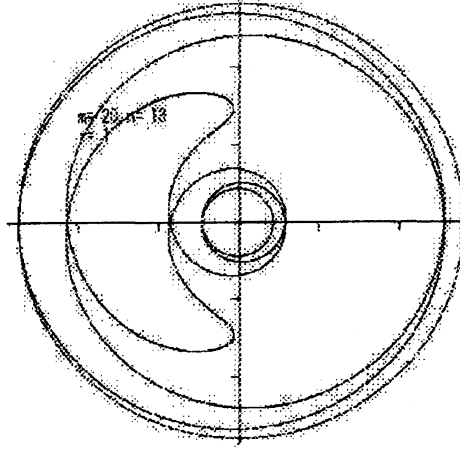
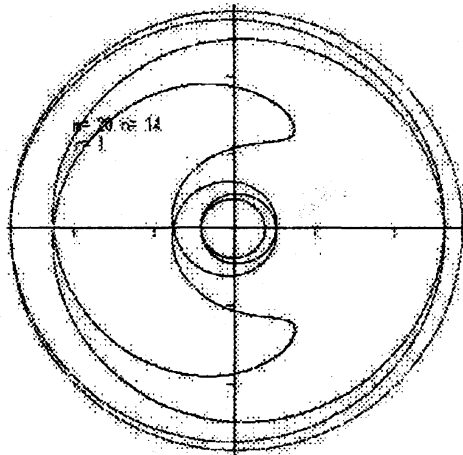
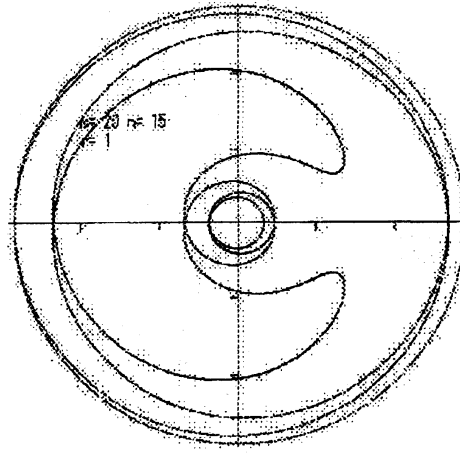
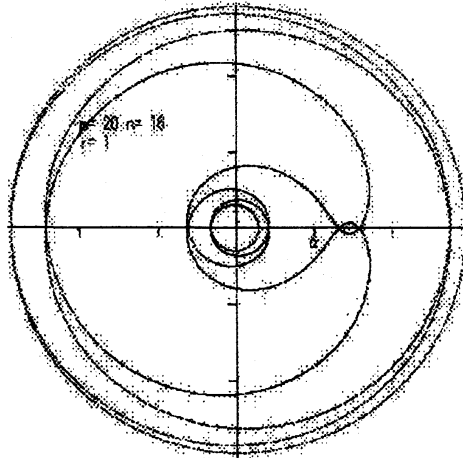
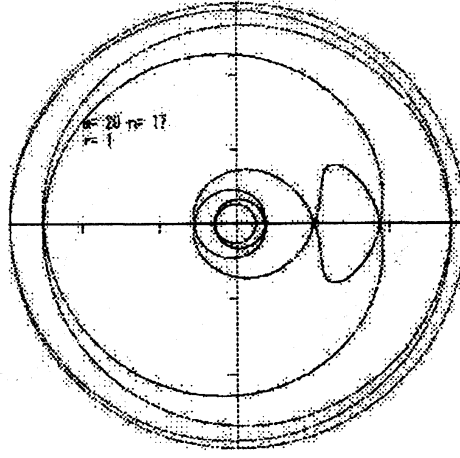
Figure 7:  $m=20, n=12$  logFigure 8:  $m=20, n=13$  logFigure 9:  $m=20, n=14$  logFigure 10:  $m=20, n=15$  logFigure 11:  $m=20, n=16$  logFigure 12:  $m=20, n=17$  log

Figure 13:  $m=40, n=40$

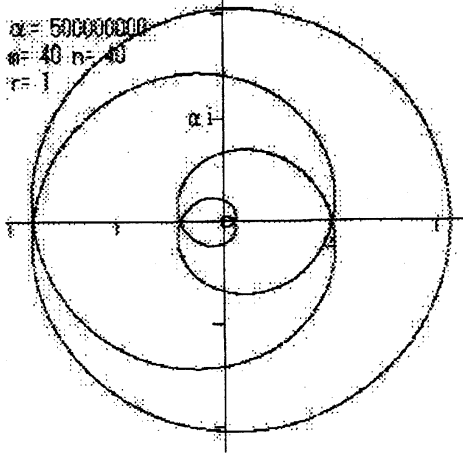


Figure 14:  $m=40, n=40 \text{ log}$

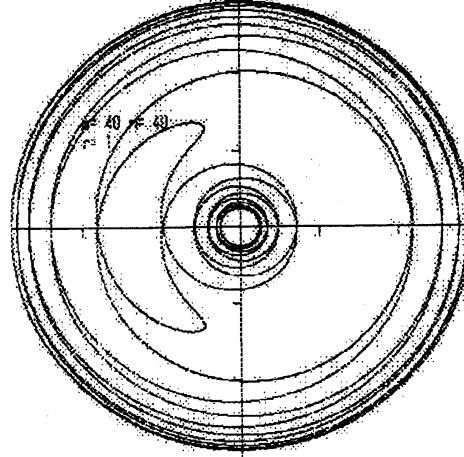


Figure 15:  $m=5, n=10 \text{ log}$

