

ON HYPERBOLIC POLYNOMIAL DIFFEOMORPHISMS OF \mathbb{C}^2

石井 豊 (九州大学数理学研究院)
Yutaka ISHII (Department of Mathematics, Kyushu University)

CONTENTS

1. Introduction and Main Result	1
2. Hyperbolicity: A Motivation	2
3. Some Preliminary Results	2
4. A Criterion for Hyperbolicity	3
5. Fusion of Two Polynomials	6
6. Rigorous Numerics Technique	7
7. Proof of Main Theorem	8
References	9

1. INTRODUCTION AND MAIN RESULT

The purpose of this note is to sketch a proof of the result stated in Main Theorem below. Consider a cubic *complex Hénon map*:

$$f_{a,b} : (x, y) \mapsto (-x^3 + a - by, x)$$

with $(a, b) = (-1.35, 0.2)$ and let J be the *Julia set* of $f_{a,b}$.

Main Theorem. *The cubic complex Hénon map above is hyperbolic but is not topologically conjugate on J to a small perturbation of any expanding polynomial in one variable.*

Here, a Hénon map or, more generally, a polynomial diffeomorphism f of \mathbb{C}^2 is said to be *hyperbolic* if its Julia set is a hyperbolic set for f (see Definition 2.2 and Lemma 3.3). Hyperbolic polynomial diffeomorphisms of \mathbb{C}^2 have been extensively studied, e.g., from the viewpoint of Axiom A theory by [BS1] and the combinatorial point of view *à la* Douady–Hubbard by [BS7]. In [HO2, FS] it has been shown that a sufficiently small perturbation of any expanding polynomial $p(x)$ of one variable in the *generalized Hénon family*:

$$f_{p,b} : (x, y) \mapsto (p(x) - by, x)$$

is hyperbolic. However, this was so far the only known example of a polynomial diffeomorphism of \mathbb{C}^2 which was rigorously shown to be hyperbolic. Moreover, the dynamics of such $f_{p,b}$ can be modeled by the projective limit of the one-dimensional map $p(x)$ on its Julia set. Thus, it was not known whether there exists a hyperbolic polynomial diffeomorphism of \mathbb{C}^2 which can not be obtained in this way, and the above theorem provides the first example of a hyperbolic complex Hénon map with essentially two-dimensional dynamics.

In the rest of this article, we will outline the proof of Main Theorem which relies on some analytic tools from complex analysis (see Section 4), a combinatorial idea called the *fusion* to construct two-dimensional dynamics from polynomials in one variable (see Section 5), and rigorous numerics technique by employing interval arithmetic (see Section 6).

2. HYPERBOLICITY: A MOTIVATION

Let $f : M \rightarrow M$ be a diffeomorphism from a Riemannian manifold M to itself. We say that a point $p \in M$ belongs to the *non-wandering set* Ω_f if for any neighborhood U of p there exists n so that $U \cap f^n(U) \neq \emptyset$. Apparently, periodic points of f belong to Ω_f .

Definition 2.1. A compact invariant subset $\Lambda \subset M$ is said to be *hyperbolic* if there exist constants $C > 0$ and $0 < \lambda < 1$, and a splitting $T_p M = E_p^u \oplus E_p^s$ for $p \in \Omega_f$ so that

- (i) $Df(E_p^{u/s}) = E_{f(p)}^{u/s}$,
- (ii) $\|Df_p^n(v)\| \leq C\lambda^n \|v\|$ for $v \in E_p^s$,
- (iii) $\|Df_p^{-n}(v)\| \leq C\lambda^n \|v\|$ for $v \in E_p^u$

for all $n > 0$ and $p \in \Omega_f$.

A fundamental concept in the dynamical system theory since 1960's is

Definition 2.2. We say that a diffeomorphism $f : M \rightarrow M$ satisfies *Axiom A* if Ω_f is a hyperbolic set and periodic points are dense in Ω_f .

Since the celebrated paper [Sm], it was widely believed that the maps satisfying Axiom A are dense in the space of all systems. Although this belief turned out to be false in some cases, it has been always a driving force for research of dynamical systems.

For polynomial diffeomorphisms of \mathbb{C}^2 , the only known example of an Axiom A map is a small perturbation $f_{p,b}$ of an expanding polynomial p in one variable [HO2, FS]. Moreover, the dynamics of such map $f_{p,b}$ is topologically conjugate to the projective limit of p on its Julia set $\hat{p} : \varprojlim(p, J_p) \rightarrow \varprojlim(p, J_p)$, so it does not present essentially two-dimensional dynamical features. In view of the belief above, it is thus natural to ask the following

Question. Does there exist an Axiom A polynomial diffeomorphism of \mathbb{C}^2 which is not conjugate on its Julia set to the projective limit of any expanding polynomial in one variable?

Note that, for a polynomial diffeomorphism of \mathbb{C}^2 , its Julia set is hyperbolic if and only if it satisfies Axiom A (see Lemma 3.3). The answer to this question was not known for the last 15 years, and our Main Theorem gives an affirmative answer to it.

3. SOME PRELIMINARY RESULTS

Let f be a polynomial diffeomorphism of \mathbb{C}^2 . It is known by a result of Friedland and Milnor [FM] that f is conjugate to either (i) an affine map, (ii) an elementary map, or (iii) the composition of finitely many generalized complex Hénon maps. Since the affine maps and the elementary maps do not present dynamically interesting behavior, we will hereafter focus only on a map in the class (iii), i.e. a map of the form $f = f_{p_1, b_1} \circ \cdots \circ f_{p_k, b_k}$ throughout this article. The product $d \equiv \deg p_1 \cdots \deg p_k$ is called the (*algebraic*) *degree* of f . Note also that we have $b \equiv \det(Df) = \det(Df_{p_1, b_1}) \cdots \det(Df_{p_k, b_k}) = b_1 \cdots b_k$.

For a polynomial diffeomorphism f , let us define

$$K_f^\pm = K^\pm \equiv \{(x, y) \in \mathbb{C}^2 : \{f^{\pm n}(x, y)\}_{n>0} \text{ is bounded in } \mathbb{C}^2\},$$

i.e. K^+ (resp. K^-) is the set of points whose forward (resp. backward) orbits are bounded in \mathbb{C}^2 . We also put $K \equiv K^+ \cap K^-$ and $J^\pm \equiv \partial K^\pm$. The *Julia set* of f is defined as $J_f = J \equiv J^+ \cap J^-$ [HO1]. Obviously these sets are invariant by f .

Hereafter, we will often consider two different spaces $\mathcal{A}^* \subset \mathbb{C}^2$ where $*$ = \mathfrak{D} or \mathfrak{R} , and consider a polynomial diffeomorphism $f : \mathcal{A}^{\mathfrak{D}} \rightarrow \mathcal{A}^{\mathfrak{R}}$ (notice that this does not necessarily mean $f(\mathcal{A}^{\mathfrak{D}}) \subset \mathcal{A}^{\mathfrak{R}}$). Here, \mathfrak{D} signifies the domain and \mathfrak{R} signifies the range of f .

A subset of $T_p\mathbb{C}^2$ is called a *cone* if it can be expressed as the union of complex lines through the origin of $T_p\mathbb{C}^2$. Let $\{C_p^*\}_{p \in \mathcal{A}^*}$ ($* = \mathfrak{D}, \mathfrak{R}$) be two cone fields in $T_p\mathbb{C}^2$ over \mathcal{A}^* and $\|\cdot\|_*$ be metrics in C_p^* .

Definition 3.1 (Pair of Expanding Cone Fields). We say that $(\{C_p^{\mathfrak{D}}\}_{p \in \mathcal{A}^{\mathfrak{D}}}, \|\cdot\|_{\mathfrak{D}})$ and $(\{C_p^{\mathfrak{R}}\}_{p \in \mathcal{A}^{\mathfrak{R}}}, \|\cdot\|_{\mathfrak{R}})$ form a pair of expanding cone fields for f (or, f expands the pair of cone fields) if there exists a constant $\lambda > 1$ so that

$$Df(C_p^{\mathfrak{D}}) \subset C_{f(p)}^{\mathfrak{R}} \quad \text{and} \quad \lambda\|v\|_{\mathfrak{D}} \leq \|Df(v)\|_{\mathfrak{R}}$$

hold for all $p \in \mathcal{A}^{\mathfrak{D}} \cap f^{-1}(\mathcal{A}^{\mathfrak{R}})$ and all $v \in C_p^{\mathfrak{D}}$. Similarly, a pair of contracting cone fields for f is defined as a pair of expanding cone fields for f^{-1} .

In particular, when $\mathcal{A} \equiv \mathcal{A}^{\mathfrak{D}} = \mathcal{A}^{\mathfrak{R}}$, $\|\cdot\| \equiv \|\cdot\|_{\mathfrak{D}} = \|\cdot\|_{\mathfrak{R}}$ and $C_p^u \equiv C_p^{\mathfrak{D}} = C_p^{\mathfrak{R}}$ for all $p \in \mathcal{A} \cap f^{-1}(\mathcal{A})$ and the above condition holds, then we say $(\{C_p^u\}_{p \in \mathcal{A}}, \|\cdot\|)$ forms an *expanding cone field* (or, f expands the cone field). Similarly, the notion of *contracting cone field* (or, f contracts the cone field) can be defined.

The next claim tells that, to prove hyperbolicity, it is sufficient to construct some expanding/contracting cone fields.

Lemma 3.2. If $f : \mathcal{A} \rightarrow \mathcal{A}$ has both nonempty expanding/contracting cone fields $\{C_p^{u/s}\}_{p \in \mathcal{A}}$, then f is hyperbolic on $\bigcap_{n \in \mathbb{Z}} f^n(\mathcal{A})$.

On the hyperbolicity of the polynomial diffeomorphisms of \mathbb{C}^2 , the following fact is known (see [BS1], Lemma 5.5 and Theorem 5.6).

Lemma 3.3. J_f is a hyperbolic set for f if and only if f satisfies Axiom A.

Thanks to this fact, one may simply say that a polynomial diffeomorphism f is *hyperbolic* when the Julia set J_f is a hyperbolic set for f as in Introduction. In what follows, we thus prove hyperbolicity of $f_{a,b}$ on its Julia set J_f .

4. A CRITERION FOR HYPERBOLICITY

Let A_x and A_y be bounded regions in \mathbb{C} . Let us put $\mathcal{A} = A_x \times A_y$, and let $\pi_x : \mathcal{A} \rightarrow A_x$ and $\pi_y : \mathcal{A} \rightarrow A_y$ be two projections. Below, we will define two types of cone fields. The first one (to which we do not assign a metric) looks more general than the other.

Definition 4.1 (Horizontal/Vertical Cone Fields). A cone field on \mathcal{A} is called a *horizontal cone field* if each cone contains the horizontal direction but not the vertical direction. A *vertical cone field* can be defined similarly.

Next, a very specific cone field is defined in terms of Poincaré metrics. Let $|\cdot|_D$ be the Poincaré metric in a bounded domain $D \subset \mathbb{C}$. Define a cone field in terms of the “slope” with respect to the Poincaré metrics in A_x and A_y as follows:

$$C_p^h \equiv \{v = (v_x, v_y) \in T_p\mathcal{A} : |v_x|_{A_x} \geq |v_y|_{A_y}\}.$$

A metric in this cone is given by $\|v\|_h \equiv |D\pi_x(v)|_{A_x}$.

Definition 4.2 (Poincaré Cone Fields). We call $(\{C_p^h\}_{p \in \mathcal{A}}, \|\cdot\|_h)$ the *horizontal Poincaré cone field*. The *vertical Poincaré cone field* $(\{C_p^v\}_{p \in \mathcal{A}}, \|\cdot\|_v)$ can be defined similarly.

A product set $\mathcal{A} = A_x \times A_y$ equipped with the horizontal/vertical Poincaré cone fields is called a *Poincaré box*. A Poincaré box will be a building block for verifying hyperbolicity of polynomial diffeomorphisms throughout this work.

Let $\mathcal{A}^* = A_x^* \times A_y^*$ ($*$ = $\mathfrak{D}, \mathfrak{R}$) be two Poincaré boxes, $f : \mathcal{A}^{\mathfrak{D}} \rightarrow \mathcal{A}^{\mathfrak{R}}$ be a holomorphic injection and $\iota : \mathcal{A}^{\mathfrak{D}} \cap f^{-1}(\mathcal{A}^{\mathfrak{R}}) \rightarrow \mathcal{A}^{\mathfrak{D}}$ be the inclusion map. The following two conditions will be used to state our criterion for hyperbolicity.

Definition 4.3 (Crossed Mapping Condition). We say that $f : \mathcal{A}^{\mathfrak{D}} \rightarrow \mathcal{A}^{\mathfrak{R}}$ satisfies the crossed mapping condition (CMC) of degree d if

$$\rho_f \equiv (\pi_x^{\mathfrak{R}} \circ f, \pi_y^{\mathfrak{D}} \circ \iota) : \iota^{-1}(\mathcal{A}^{\mathfrak{D}}) \cap f^{-1}(\mathcal{A}^{\mathfrak{R}}) \longrightarrow A_x^{\mathfrak{R}} \times A_y^{\mathfrak{D}}$$

is proper of degree d .

Let $\mathcal{F}_h^{\mathfrak{D}} = \{A_x^{\mathfrak{D}}(y)\}_{y \in A_y^{\mathfrak{D}}}$ be the horizontal foliation of $\mathcal{A}^{\mathfrak{D}}$ with leaves $A_x^{\mathfrak{D}}(y) = A_x^{\mathfrak{D}} \times \{y\}$ and $\mathcal{F}_v^{\mathfrak{R}} = \{A_y^{\mathfrak{R}}(x)\}_{x \in A_x^{\mathfrak{R}}}$ be the vertical foliation of $\mathcal{A}^{\mathfrak{R}}$ with leaves $A_y^{\mathfrak{R}}(x) = \{x\} \times A_y^{\mathfrak{R}}$.

Definition 4.4 (No-Tangency Condition). We say that $f : \mathcal{A}^{\mathfrak{D}} \rightarrow \mathcal{A}^{\mathfrak{R}}$ satisfies the no-tangency condition (NTC) if $f(\mathcal{F}_h^{\mathfrak{D}})$ and $\mathcal{F}_v^{\mathfrak{R}}$ have no tangencies. Similarly we say that $f^{-1} : \mathcal{A}^{\mathfrak{R}} \rightarrow \mathcal{A}^{\mathfrak{D}}$ satisfies the (NTC) if $\mathcal{F}_h^{\mathfrak{D}}$ and $f^{-1}(\mathcal{F}_v^{\mathfrak{R}})$ have no tangencies.

Notice that we do not exchange h and v of the foliations in the definition of the non-tangency condition for f^{-1} . Hence, f satisfies the (NTC) iff so does f^{-1} .

The following elementary example illustrates the two conditions given above.

Example. Given a polynomial diffeomorphism f , choose a sufficiently large $R > 0$. Put $\Delta_x(a; r) = \{x \in \mathbb{C} : |x - a| < r\}$, $\mathcal{D}_R = \Delta_x(0; R) \times \Delta_y(0; R)$, $V^+ = V_R^+ \equiv \{(x, y) \in \mathbb{C}^2 : |x| \geq R, |x| \geq |y|\}$ and $V^- = V_R^- \equiv \{(x, y) \in \mathbb{C}^2 : |y| \geq R, |y| \geq |x|\}$. Then, f induces a homomorphism:

$$f_* : H_2(\mathcal{D}_R \cup V^+, V^+) \longrightarrow H_2(\mathcal{D}_R \cup V^+, V^+).$$

Since $H_2(\mathcal{D}_R \cup V^+, V^+) = \mathbb{Z}$, one can define the (topological) degree of f to be $f_*(1)$. It is easy to see that the topological degree of f is equal to the algebraic degree d of f .

Consider $f : \mathcal{D}_R \rightarrow \mathcal{D}_R$ and $\rho_f : \mathcal{D}_R \cap f^{-1}(\mathcal{D}_R) \rightarrow \mathcal{D}_R$. Given $(x, y) \in \mathcal{D}_R$, $f(\rho^{-1}(x, y))$ is equal to $f(D_x(y)) \cap D_y(x)$, where we write $D_x(y) = \Delta_x(0; R) \times \{y\}$ and $D_y(x) = \{x\} \times \Delta_y(0; R)$. Since $f(V^+) \subset V^+$ and $f^{-1}(V^-) \subset V^-$ hold, the number $\text{card}(f(D_x(y)) \cap D_y(x))$ can be counted by the number of times $\pi_x \circ f(\partial D_x(y))$ rounds around $\Delta_x(0; R)$ by the Argument Principle. This is equal to the degree of f , so it follows that $\text{card}(f(D_x(y)) \cap D_y(x)) = d$ counted with multiplicity for all $(x, y) \in \mathcal{D}_R$. Thus, $f : \mathcal{D}_R \rightarrow \mathcal{D}_R$ satisfies the (CMC). Notice that $f : \mathcal{D}_R \rightarrow \mathcal{D}_R$ satisfies the (NTC) iff $\text{card}(f(D_x(y)) \cap D_y(x)) = d$ counted without multiplicity for all $(x, y) \in \mathcal{D}_R$. (End of Example.)

Now, the central claim for verifying hyperbolicity is stated as

Theorem 4.5 (Hyperbolicity Criterion). Assume that $f : \mathcal{A}^{\mathfrak{D}} \rightarrow \mathcal{A}^{\mathfrak{R}}$ satisfies the crossed mapping condition (CMC) of degree $d \geq 2$. Then, the following are equivalent:

- (i) f preserves some pair of horizontal cone fields,
- (ii) f^{-1} preserves some pair of vertical cone fields,
- (iii) f expands the pair of the horizontal Poincaré cone fields,
- (iv) f^{-1} expands the pair of the vertical Poincaré cone fields,
- (v) f satisfies the no-tangency condition (NTC),
- (vi) f^{-1} satisfies the no-tangency condition (NTC).

Moreover, when $\mathcal{A}^{\mathfrak{D}} = \mathcal{A}^{\mathfrak{R}} = \mathcal{B} = B_x \times B_y$, where B_x and B_y are bounded open topological disks in \mathbb{C} , then any of the six conditions above is equivalent to the following:

- (vii) $\mathcal{B} \cap f^{-1}(\mathcal{B})$ has d connected components.

The (CMC) and the (NTC) can be rewritten as more checkable conditions so that we can verify the hyperbolicity of some specific polynomial diffeomorphisms of \mathbb{C}^2 . To do this, given two open subsets V and W of \mathbb{C} , let us write the vertical boundary $\partial_v(V \times W) = \partial V \times W$ and the horizontal boundary $\partial_h(V \times W) = V \times \partial W$.

Definition 4.6 (Boundary Compatibility Condition). We say that $f : \mathcal{A}^{\mathfrak{D}} \rightarrow \mathcal{A}^{\mathfrak{R}}$ satisfies the boundary compatibility condition (BCC) if

- (i) $\text{dist}(\pi_x^{\mathfrak{R}} \circ f(\partial_v \mathcal{A}^{\mathfrak{D}}), A_x^{\mathfrak{R}}) > 0$ and
- (ii) $\text{dist}(\pi_y^{\mathfrak{D}} \circ f^{-1}(\partial_h \mathcal{A}^{\mathfrak{R}}), A_y^{\mathfrak{D}}) > 0$

hold, where $\text{dist}(\cdot, \cdot)$ means the Euclidean distance between two sets in \mathbb{C} .

Let us define

$$\mathcal{C} = \mathcal{C}_f \equiv \bigcup_{y \in A_y^{\mathfrak{D}}} \{\text{critical points of } \pi_x^{\mathfrak{R}} \circ f : A_x^{\mathfrak{D}} \times \{y\} \rightarrow A_x^{\mathfrak{R}}\},$$

and call it the *dynamical critical set* of f .

Definition 4.7 (Off-Criticality Condition). We say that $f : \mathcal{A}^{\mathfrak{D}} \rightarrow \mathcal{A}^{\mathfrak{R}}$ satisfies the off-criticality condition (OCC) if $\text{dist}(\pi_x^{\mathfrak{R}} \circ f(\mathcal{C}_f), A_x^{\mathfrak{R}}) > 0$ holds.

It is not difficult to see that the (BCC) implies the (CMC), and the (OCC) implies the (NTC). Thus, the theorem above can be trivially extended to the setting

$$f : \bigsqcup_{1 \leq j \leq M_{\mathfrak{D}}} \mathcal{A}_j^{\mathfrak{D}} \longrightarrow \bigsqcup_{1 \leq k \leq M_{\mathfrak{R}}} \mathcal{A}_k^{\mathfrak{R}},$$

where each \mathcal{A}_i^* is an open set in \mathbb{C}^2 biholomorphic to a Poincaré box of the form $A_x^* \times A_y^*$ (then, two natural projections for \mathcal{A}_i^* corresponding to π_x^* and π_y^* and the notion of horizontal/vertical Poincaré cone fields in \mathcal{A}_i^* can be defined), and the domain and the range are assumed to be the *disjoint* unions of $\{\mathcal{A}_i^*\}_{1 \leq i \leq M_*}$. Then, Theorem 4.5 can be restated as

Corollary 4.8. If $f : \mathcal{A}_j^{\mathfrak{D}} \rightarrow \mathcal{A}_k^{\mathfrak{R}}$ satisfies the (BCC) and the (OCC) for $1 \leq j \leq M_{\mathfrak{D}}$ and $1 \leq k \leq M_{\mathfrak{R}}$, then f expands the pair of the horizontal Poincaré cone fields and contracts the pair of the vertical Poincaré cone fields on their unions. In particular, if $\mathcal{A}_i^{\mathfrak{D}} = \mathcal{A}_i^{\mathfrak{R}} = \mathcal{A}_i$ for all $1 \leq i \leq M \equiv M_{\mathfrak{D}} = M_{\mathfrak{R}}$ and $f : \mathcal{A}_j \rightarrow \mathcal{A}_k$ satisfies the (BCC) and the (OCC) for all $1 \leq j, k \leq M$, then f is hyperbolic on $\bigcap_{n \in \mathbb{Z}} f^n(\bigsqcup_{1 \leq i \leq M} \mathcal{A}_i)$.

As a by-product of this criterion, we can give explicit bounds on parameter regions of hyperbolic maps in the (quadratic) Hénon family:

$$f_{c,b} : (x, y) \longmapsto (x^2 + c - by, x),$$

where $b \in \mathbb{C}^\times = \mathbb{C} \setminus \{0\}$ and $c \in \mathbb{C}$ are complex parameters.

Corollary 4.9. If (c, b) satisfies either

- (i) $|c| > 2(1 + |b|)^2$ (a hyperbolic horseshoe case),
- (ii) $c = 0$ and $|b| < (\sqrt{2} - 1)/2$ (an attractive fixed point case) or
- (iii) $c = -1$ and $|b| < 0.02$ (an attractive cycle of period two case),

then the complex Hénon map $f_{c,b}$ is hyperbolic on J .

Notice that [HO2, FS] did not give any specific bounds on the possible perturbation width $|b|$ which keeps the hyperbolicity of $f_{c,b}$.

We can extend the hyperbolicity criterion above to the case where some Poincaré boxes have overlaps in the following way. Let $\{\mathcal{A}_i\}_{i=0}^N$ be a family of Poincaré boxes in \mathbb{C}^2 each of which is biholomorphic to a product set of the form $A_x^i \times A_y^i$ with its horizontal Poincaré cone field $\{C_p^{\mathcal{A}_i}\}_{p \in \mathcal{A}_i}$ in \mathcal{A}_i . Let us write $\mathcal{A} = \bigcup_{i=0}^N \mathcal{A}_i$.

Definition 4.10 (Gluing of Poincaré Boxes). For each $p \in \mathcal{A}$, let us write $I(p) \equiv \{i : p \in \mathcal{A}_i\}$. We shall define a cone field $\{C_p^\cap\}_{p \in \mathcal{A}}$ by

$$C_p^\cap \equiv \bigcap_{i \in I(p)} C_p^{\mathcal{A}_i}$$

for $p \in \mathcal{A}$ and a metric $\|\cdot\|_\cap$ in it by

$$\|v\|_\cap \equiv \min\{\|v\|_{\mathcal{A}_i} : i \in I(p)\}$$

for $v \in C_p^\cap$.

Remark 4.11. A priori we do not know if C_p^\cap is non-empty for p with $\text{card}(I(p)) \geq 2$.

Given a subset $I \subset \{0, 1, \dots, N\}$, let us write

$$\langle I \rangle \equiv \left(\bigcap_{i \in I} \mathcal{A}_i \right) \setminus \left(\bigcup_{j \in I^c} \mathcal{A}_j \right) = \{p \in \mathcal{A} : I(p) = I\}.$$

In what follows, we only consider the case $\text{card}(I(p)) \leq 2$. One then sees, for example, $\langle i \rangle = \mathcal{A}_i \setminus \bigcup_{j \neq i} \mathcal{A}_j$ and $\langle i, j \rangle = \mathcal{A}_i \cap \mathcal{A}_j$.

A crucial step in the proof of Main Theorem is to combine the hyperbolicity criterion with the following:

Lemma 4.12 (Gluing Lemma). Let $p \in \mathcal{A} \cap f^{-1}(\mathcal{A})$. If for any $i \in I(f(p))$ there exists $j = j(i) \in I(p)$ such that $f : \mathcal{A}_j \rightarrow \mathcal{A}_i$ satisfies the (BCC) and the (OCC), then there is a constant $\lambda > 1$ so that $Df(C_p^\cap) \subset C_{f(p)}^\cap$ and $\|Df(v)\|_\cap \geq \lambda \|v\|_\cap$ for $v \in C_p^\cap$.

5. FUSION OF TWO POLYNOMIALS

In this section we present a model study of fusion.

Think of two cubics $p_1(x)$ and $p_2(x)$ so that $p_2(x) = p_1(x) + \delta$ for some $\delta > 0$, both have negative leading coefficients and have two real critical points $c_1 > c_2$. Let $\Delta_x(0; R) = \{|x| < R\}$ and $\Delta_y(0; R) = \{|y| < R\}$. Take $R > 0$ sufficiently large so that $\partial\Delta_x(0; R) \times \Delta_y(0; R) \subset \text{int}V^+$ and $\Delta_x(0; R) \times \partial\Delta_y(0; R) \subset \text{int}V^-$ hold. Assume that p_i satisfies $p_1(c_2) < -R$, $p_2(c_2) < -R$ and $p_2(c_1) > R$ so that the orbits $|p_1^k(c_2)|$, $|p_2^k(c_1)|$ and $|p_2^k(c_2)|$ go to infinity as $k \rightarrow \infty$. Assume also that c_1 is a super-attractive fixed point for p_1 . Define $B_{y,1}$ to be the connected component of $p_1^{-1}(\Delta_y(0; R))$ containing c_1 and $B_{y,2}$ to be the other component. Let H be a closed neighborhood of c_1 which is contained in the attractive basin of c_1 . Put $\mathcal{A}_1 = (\Delta_x(0; R) \setminus H) \times B_{y,1}$ and $\mathcal{A}_2 = \Delta_x(0; R) \times B_{y,2}$. Now, we assume that there exists a generalized Hénon map f with

$$(1) \quad f|_{\mathcal{A}_i}(x, y) \approx (p_i(x), x)$$

for $i = 1, 2$.

(a) Consider $f : \mathcal{A}_1 \rightarrow \mathcal{A}_1 \cup \mathcal{A}_2$. Then, the (BCC) would hold since

$$\overline{f(H \times B_{y,1})} \approx \overline{p_1(H) \times H} \subset \text{int}(H \times B_{y,1})$$

by the approximation (1) above and $R > 0$ is large. Also the (OCC) would hold since

$$\overline{f(\{c_1\} \times B_{y,1})} \approx \overline{\{p_1(c_1)\} \times \{c_1\}} \subset \text{int}(H \times B_{y,1})$$

and

$$\overline{f(\{c_2\} \times B_{y,1})} \approx \overline{\{p_1(c_2)\} \times \{c_2\}} \subset \text{int}V^+$$

again by (1). Thus we may conclude that $f : \mathcal{A}_1 \rightarrow \mathcal{A}_1 \cup \mathcal{A}_2$ satisfies the (BCC) and the (OCC) if the argument above is verified rigorously.

(b) Consider $f : \mathcal{A}_2 \rightarrow \mathcal{A}_1 \cup \mathcal{A}_2$. Since \mathcal{A}_2 does not have any holes like H and $R > 0$ is large, the (BCC) would hold for f on \mathcal{A}_2 . Also the (OCC) would hold since

$$\overline{f(\{c_1\} \times B_{y,2})} \approx \overline{\{p_2(c_1)\} \times \{c_1\}} \subset \text{int}V^+$$

and

$$\overline{f(\{c_2\} \times B_{y,2})} \approx \overline{\{p_2(c_2)\} \times \{c_2\}} \subset \text{int}V^+.$$

Thus we may conclude that $f : \mathcal{A}_2 \rightarrow \mathcal{A}_1 \cup \mathcal{A}_2$ satisfies the (BCC) and the (OCC) if the argument above is verified.

Combining these two considerations, we may expect that $f : \mathcal{A}_1 \cup \mathcal{A}_2 \rightarrow \mathcal{A}_1 \cup \mathcal{A}_2$ is hyperbolic on $\bigcap_{n \in \mathbb{Z}} f^n(\mathcal{A}_1 \cup \mathcal{A}_2)$ by the hyperbolicity criterion. In this way, the generalized Hénon map $f_{p,b}$ restricted to $\mathcal{A}_1 \cup \mathcal{A}_2$ can be viewed as a *fusion* of two polynomials $p_1(x)$ and $p_2(x)$ in one variable. This method enables us to construct a topological model of the dynamics of a generalized Hénon map which have essentially two-dimensional dynamics.

6. RIGOROUS NUMERICS TECHNIQUE

Computer do not understand all real numbers. Let \mathbb{F}^* be the set of real numbers which can be represented by binary floating point numbers no longer than a certain length of digits and put $\mathbb{F} \equiv \mathbb{F}^* \cup \{\infty\}$. Denote by \mathcal{J} the set of all closed intervals with their end points in \mathbb{F} . Given $x \in \mathbb{R}$, let $\downarrow x \downarrow$ be the largest number in \mathbb{F} which is less than x and let $\uparrow x \uparrow$ be the smallest number in \mathbb{F} which is greater than x (when such number does not exist in \mathbb{F}^* , we assign ∞). It then follows that

$$x \in [\downarrow x \downarrow, \uparrow x \uparrow] \in \mathcal{J}.$$

Interval arithmetic is a set of operations to output an interval in \mathcal{J} from given two intervals in \mathcal{J} . It contains at least four basic operations: addition, differentiation, multiplication and division. Specifically, the addition of given two intervals $I_1 = [a, b]$, $I_2 = [c, d] \in \mathcal{J}$ is defined by

$$I_1 + I_2 \equiv [\downarrow a + c \downarrow, \uparrow b + d \uparrow].$$

It then rigorously follows that $\{x+y : x \in I_1, y \in I_2\} \subset I_1 + I_2$. The other three operations can be defined similarly. A point $x \in \mathbb{R}$ is represented as the small interval $[\downarrow x \downarrow, \uparrow x \uparrow] \in \mathcal{J}$. We also write $[a, b] < [c, d]$ when $b < c$.

In this article interval arithmetic will be employed to prove rigorously the (BCC) and the (OCC) for a given polynomial diffeomorphism of \mathbb{C}^2 . It should be easy to imagine how this technique is used for checking the (BCC); we simply cover the vertical boundary of $\mathcal{A}^{\mathcal{D}}$ by small real four-dimensional cubes (i.e. product sets of four small intervals) in \mathbb{C}^2 and see how they are mapped by $\pi_x \circ f$. Thus, below we explain how interval arithmetic will be applied to check the (OCC).

The problem of checking the (OCC) for a given generalized Hénon map $f_{p,b}$ reduces to finding the zeros of the derivative $\frac{d}{dx}(p(x) - by_0)$ for each fixed $y_0 \in A_y^{\mathcal{D}}$. Essentially, this means that one has to find the zeros for a family of polynomials $q_y(x)$ in x parameterized by $y \in A \subset \mathbb{C}$. To do this, we first apply Newton's method to know approximate locations of its zeros. However, this method can not tell how many zeros we found in the region since it does not detect the multiplicity of zeros.

In order to count the multiplicity we employ the idea of winding number. That is, we first fix $y \in A$ and write a small circle in the x -plane centered at the approximate location of a zero (which we had already found by Newton's method). We map the circle by q_y and count how it rounds around the image of the approximate zero, which gives both the existence and the number of zeros inside the small circle. Our method to count the winding number on computer is the following. We may assume that the image of the approximate zero is the origin of the complex plane. Cover the small circle by many tiny squares and map them by q_y . We then verify the following two points (i) check that the images of the squares have certain distance from the origin which is much larger than the size of the image squares, and (ii) count the number of changes of the signs in the real and the imaginary parts of the sequence of image squares. These data tell how the image squares move one quadrant to another (note that the transition between the first and the third quadrants and between the second and the fourth are prohibited by (i)), and if the signs change properly, we are able to know the winding number of the image of the small circle.

An advantage of this method is that, since the winding number is integer-valued, its mathematical rigorous justification becomes easier (there is almost no room for round-off errors to be involved). Another advantage of this winding number method is its stability; once we check that the image of the circle by q_y rounds a point desired number of times for a fixed parameter y , then this is often true for any nearby parameters. So, by dividing the parameter set A into small squares and verifying the above points for each squares, we can rigorously trace the zeros of q_y for all $y \in A$.

7. PROOF OF MAIN THEOREM

Let $f = f_{a,b}$ be the cubic complex Hénon map under consideration as in the Introduction. We first define four specific Poincaré boxes $\{\mathcal{A}_i\}_{i=0}^3$ with associated Poincaré cone fields $\{C_p^{\mathcal{A}_i}\}_{p \in \mathcal{A}_i}$ for $0 \leq i \leq 3$, where \mathcal{A}_1 and \mathcal{A}_2 are biholomorphic to a bidisk and $\pi_1(\mathcal{A}_i) = \mathbb{Z}$ for $i = 0, 3$. As was seen in Definition 4.10, we can define the new cone field $(\{C_p^\cap\}_{p \in \mathcal{A}_1}, \|\cdot\|_\cap)$ by using $\{C_p^{\mathcal{A}_i}\}_{p \in \mathcal{A}_i}$. See Figure 1 below, where we described how the boxes are sitting in \mathbb{C}^2 , how they are overlapped and how they are mapped by f . The shaded regions are the holes of \mathcal{A}_0 and \mathcal{A}_3 and their images. Note that the two disjoint Poincaré boxes \mathcal{A}_i ($i = 1, 2$) are figured out in the same place in Figure 1.

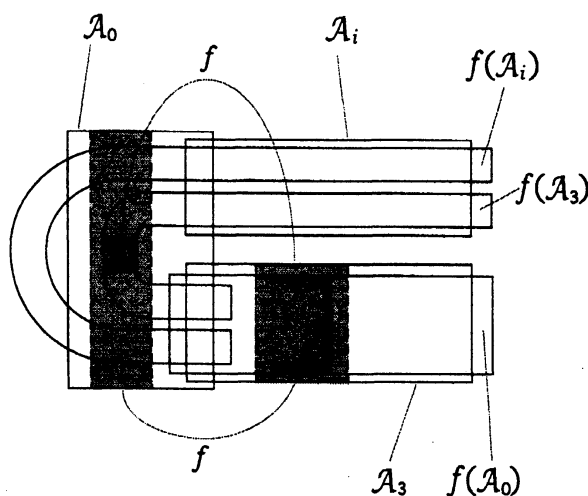

Figure 1. Poincaré boxes for the cubic Hénon map $f_{a,b}$.

With a help of rigorous numerics technique described in the previous section we are able to get the

Proposition 7.1. *There are 10 programs written in C++ which rigorously verify the following assertions using interval arithmetic:*

- (i) $J_f \subset \mathcal{A}$,
- (ii) *The following transitions: $\mathcal{A}_0 \rightarrow \mathcal{A}_3$, $\mathcal{A}_1 \rightarrow \mathcal{A}_0$, $\mathcal{A}_1 \rightarrow \mathcal{A}_1$, $\mathcal{A}_1 \rightarrow \mathcal{A}_2$, $\mathcal{A}_2 \rightarrow \mathcal{A}_0$, $\mathcal{A}_2 \rightarrow \mathcal{A}_1$, $\mathcal{A}_2 \rightarrow \mathcal{A}_2$, $\mathcal{A}_3 \rightarrow \mathcal{A}_0$, $\mathcal{A}_3 \rightarrow \mathcal{A}_1$ and $\mathcal{A}_3 \rightarrow \mathcal{A}_2$ by f satisfy the (BCC) and the (OCC),*
- (iii) *There exists a bidisk $\mathcal{V} \supset \bigcap_{|n| \leq 2} f^n(\mathcal{A}_0 \cap \mathcal{A}_3)$ so that $f : \mathcal{V} \rightarrow \mathcal{V}$ satisfies the (BCC) of degree one.*

Combining this proposition with Corollary 4.8 and the Gluing Lemma, one can conclude that the cubic Hénon map $f_{a,b}$ is hyperbolic on its Julia set.

To conclude the proof, we show that $f_{a,b}$ is not topologically conjugate to a small perturbation of any hyperbolic polynomial in one variable. Assume that $f = f_{a,b}$ is conjugate to a small perturbation $g = f_{q,b}$ of some expanding polynomial q . The degree of q then should be three, so it has two critical points. If both of their orbits diverge to infinity, then J_g is totally disconnected. However, J_f contains solenoids of period two, so this is not the case. If both of their orbits are bounded, then J_g is connected. However, J_f is not connected (note that the transitions $\mathcal{A}_i \rightarrow \mathcal{A}_0$ for $i = 1, 2$ look like a horseshoe), so this is not the case either. Thus, the only possibility is that one orbit converges to an attractive cycle and the other diverges to infinity. Note that, by comparing the number of periodic points, one sees that q has a unique attractive cycle of period two, which attracts a critical orbit. For two among the three fixed points of f , the connected component of J_f containing the fixed point consists of the point itself. For two among the three fixed points of g , the connected component of J_g containing the fixed point is homeomorphic to the projective limit $\varprojlim(p, J_p)$, where $p(x) = x^2 - 1$. It follows that f can not be topologically conjugate to g on their Julia sets. This finishes the proof of Main Theorem. Q.E.D.

For more details of the proof, consult [I].

REFERENCES

- [BS1] E. Bedford, J. Smillie, *Polynomial diffeomorphisms of \mathbb{C}^2 : Currents, equilibrium measure and hyperbolicity*. Invent. Math. **103**, no. 1, 69–99 (1991).
- [BS7] E. Bedford, J. Smillie, *Polynomial diffeomorphisms of \mathbb{C}^2 . VII: Hyperbolicity and external rays*. Ann. Sci. École Norm. Sup. **32**, no. 4, 455–497 (1999).
- [D] A. Douady, *Descriptions of compact sets in \mathbb{C}* . Topological Methods in Modern Mathematics (Stony Brook, NY, 1991), 429–465, Publish or Perish, Houston, TX, (1993).
- [FS] J. E. Fornæss, N. Sibony, *Complex Hénon mappings in \mathbb{C}^2 and Fatou-Bieberbach domains*. Duke Math. J. **65**, no. 2, 345–380 (1992).
- [FM] S. Friedland, J. Milnor, *Dynamical properties of plane polynomial automorphisms*. Ergodic Theory Dynam. Systems **9**, no. 1, 67–99 (1989).
- [HO1] J. H. Hubbard, R. W. Oberste-Vorth, *Hénon mappings in the complex domain. I: The global topology of dynamical space*. Inst. Hautes Études Sci. Publ. Math. **79**, 5–46 (1994).
- [HO2] J. H. Hubbard, R. W. Oberste-Vorth, *Hénon mappings in the complex domain. II: Projective and inductive limits of polynomials*. Real and Complex Dynamical Systems (Hillerod, 1993), 89–132, NATO Adv. Sci. Inst. Ser. C 464, Kluwer Acad. Publ., Dordrecht (1995).
- [I] Y. Ishii, *Hyperbolic polynomial diffeomorphisms of \mathbb{C}^2* . Preprint (2005).
- [Sm] S. Smale, *Differentiable dynamical systems*. Bull. Amer. Math. Soc. **73**, 747–817 (1967).