

GRAPHS AND PROJECTIVE PLAINES IN 3-MANIFOLDS

WOLFGANG HEIL

Department of Mathematics
Florida State University
Tallahassee, FL 32306-3027, U.S.A.

SEIYA NEGAMI

Department of Information Science
Tokyo Institute of Technology
Oh-okayama, Meguro-Ku, Tokyo 152, Japan

(Received March 17, 1986 and in revised form April 18, 1986)

ABSTRACT. Proper homotopy equivalent compact P^2 -irreducible and sufficiently large 3-manifolds are homeomorphic. The result is not known for irreducible 3-manifolds that contain 2-sided projective planes, even if one assumes the Poincaré conjecture. In this paper to such a 3-manifold M is associated a graph $G(M)$ that specifies how a maximal system of mutually disjoint non-isotopic projective planes is embedded in M , and it is shown that $G(M)$ is an invariant of the homotopy type of M . On the other hand it is shown that any given graph can be realized as $G(M)$ for infinitely many irreducible and boundary irreducible M .

As an application it is shown that any closed irreducible 3-manifold M that contains 2-sided projective planes can be obtained from a P^2 -irreducible 3-manifold and $P^2 \times S^1$ by removing a solid Klein bottle from each and gluing together the resulting boundaries; furthermore M contains an orientation preserving simple closed curve α such that any nontrivial Dehn surgery along α yields a P^2 -irreducible 3-manifold.

KEY WORDS AND PHRASES. P^2 -irreducible 3-manifolds, incompressible surfaces.
1986 AMS SUBJECT CLASSIFICATION CODE. 57N10.

1. INTRODUCTION

The classification theorem for compact P^2 -irreducible, sufficiently large 3-manifolds M and N asserts that if $(M, \partial M)$ is homotopy equivalent to $(N, \partial N)$, then M is homeomorphic to N [11], [3]. The assumption of being " P^2 -irreducible and sufficiently large" makes M and N aspherical which allows for modifications

of homotopy equivalences. Also, the assumption of being "irreducible" is needed to avoid the Poincaré conjecture.

In this paper, we consider P^2 -containing 3-manifolds, that is, 3-manifolds that contain a 2-sided projective plane. Epstein [1] showed that any irreducible, compact, non-orientable 3-manifold with finite fundamental group is homotopy equivalent to $P^2 \times I$, and the Poincaré conjecture would imply that it is in fact homeomorphic to $P^2 \times I$.

As a first step in trying to prove a classification theorem modulo the Poincaré conjecture for irreducible P^2 -containing 3-manifolds M , we associate to M a P^2 -graph that specifies how a maximal system of mutually disjoint non-isotopic projective planes is embedded in M , and show that it is an invariant of homotopy type. On the other hand, it is shown that any given graph can be realized as a P^2 -graph of infinitely many irreducible and ∂ -irreducible 3-manifolds. As an application, it is shown that any closed irreducible P^2 -containing 3-manifold M can be obtained from a P^2 -irreducible 3-manifold and $P^2 \times S^1$ by removing a solid Klein bottle from each and gluing together the resulting boundaries.

2. P^2 -GRAPHS

Two disjoint 2-sided projective planes P_0 and P_1 in a 3-manifold M are *parallel* (*pseudo-parallel* resp.) if there is a submanifold Q of M homeomorphic (homotopy equivalent) to $P^2 \times I$ such that $\partial Q = P_0 \cup P_1$. A maximal set of pairwise disjoint non-parallel (non pseudo-parallel) 2-sided projective planes in $\text{Int } M$ is called a *complete* (*pseudo-complete*) system of projective planes in M . Since 2-sided projective planes are incompressible, it follows from Haken's Theorem [2] that a (pseudo-)complete system in a compact 3-manifold M is finite. Moreover if M is also irreducible, a complete system is uniquely determined up to ambient isotopy [9].

We define the (coloured) P^2 -graph $G(M)$ of an irreducible 3-manifold M as follows: Choose a vertex v_i in the interior of each component C_i of M cut open along a complete system \mathcal{P} . Let v_i be coloured white if $C_i \cong P^2 \times I$ and $\partial C_i \cap \partial M$ contains a projective plane; otherwise let v_i be coloured black. Join v_i and v_j by an edge if C_i and C_j meet along a common $P^2 \in \mathcal{P}$. The resulting graph $G(M)$ may be embedded in M so that each edge intersects its corresponding P^2 transversely in a single point. (See Figure 1.) Note that a white vertex must have degree 1.

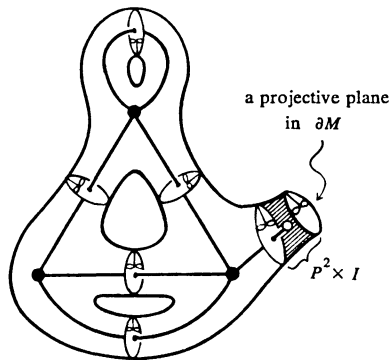

In a similar way, we define the *pseudo P^2 -graph* $G'(M)$ by starting with a pseudo-complete system P' . More explicitly, let P be a complete system,

$$P = \{P_{1,1}, \dots, P_{1,\alpha}, P_{2,1}, \dots, P_{2,\alpha}, \dots, P_{m,1}, \dots, P_{m,\alpha_m}\}$$

where the $P_{i,j}$'s have been numbered so that $P_{i,k}$ is pseudo-parallel to $P_{i,1}$ for $1 \leq k, l \leq \alpha_i$, but $P_{i,k}$ is not pseudo-parallel to $P_{j,1}$ for $i \neq j$. We can also assume that the $P_{i,j}$'s are numbered in such a way that for each $i = 1, \dots, m$ the projective planes $P_{i,1}$ and P_{i,α_i} bound a submanifold \tilde{C}_i homotopy equivalent to $P^2 \times I$ in M that contains the other $P_{i,j}$ in its interior. Then $P' = \{P_{1,1}, P_{2,1}, \dots, P_{m,1}\}$ is a pseudo-complete system for M . Let M' be the quotient obtained from M by collapsing the components \tilde{C}_i onto $P_{i,1}$ ($i = 1, \dots, m$). The P' is a complete system in M' and clearly $G(M')$ is isomorphic to $G'(M)$ as graphs.

Note that $G(M)$ and $G'(M)$ are homeomorphic as topological spaces. However if there are 3-manifolds homotopy equivalent to but not homeomorphic to $P^2 \times I$ - (any such example would provide a counter example to the Poincaré conjecture) - then $G(M)$ is obtained from $G'(M)$ by subdividing edges, and the two graphs may not be isomorphic as graphs.

Observe also that the homomorphisms on fundamental groups induced by the inclusion $i: G(M) \rightarrow M$ are injective and that the natural projection $q: M \rightarrow M'$ is a homotopy equivalence.

We now show that the pseudo-graph of M is an invariant of the relative homotopy type of M :

THEOREM 1. Let M and N be compact, irreducible 3-manifolds and let $f: (N, \partial N) \rightarrow (M, \partial M)$ be a map such that $f_*: \pi_1(N) \rightarrow \pi_1(M)$ is an isomorphism. Then $G'(N)$ and $G'(M)$ are isomorphic as coloured graphs.

COROLLARY 2. If $f: (N, \partial N) \rightarrow (M, \partial M)$ is a homotopy equivalence then $G'(N) \cong G'(M)$.

For the proof, we need a generalization of the lemma on homotopy surgery of maps [11], [5, Lemma 6.5]:

LEMMA 3. Let M be a compact 3-manifold, X a p.l. k -manifold containing a properly embedded 2-sided p.l. $(k-1)$ -submanifold Y with $\ker(\pi_1(Y) \rightarrow \pi_1(X)) = 1$. Let $f: M \rightarrow X$ be a map. Then there are disjoint homotopy 3-balls B_1, \dots, B_n with B_i in $\text{Int } M$ or $B_i \cap \partial M = \partial B_i \cap \partial M$ a disk, and there is a map $g: M_0 = M - \cup_i B_i \rightarrow X$ such that

- (i) $g_* = (f|_{M_0})_*: \pi_1(M_0) \rightarrow \pi_1(X)$,
- (ii) each component of $g^{-1}(Y)$ is a properly embedded, 2-sided incompressible surface in M_0 , and
- (iii) g maps each fiber $p \times [-1,1]$ of a product neighbourhood $g^{-1}(Y) \times [-1,1]$ of $g^{-1}(Y)$ homeomorphically to the fiber $g(p) \times [-1,1]$ of a product neighborhood $Y \times [-1,1]$ of Y .

To see this, we follow the proof of Lemma 6.5 in [5] and indicate the modifications. By a homotopy, we may assume that $f^{-1}(X)$ is a system of 2-sided surfaces.

(1) If $f^{-1}(Y)$ contains a compressible 2-sphere F , then F bounds a homotopy 3-cell C in M and we let $M'_0 = \overline{M - U}$ where U is a smaller regular neighbourhood of C , and $g = f|M'_0$.

(2) If $f^{-1}(Y)$ contains a compressible 2-cell F then F bounds together with a disk on ∂M a 3-cell C in M and we proceed as in (1).

(3) If there is a compressible disk D in $\text{Int } M$ with $D \cap f^{-1}(Y) = \partial D$ and ∂D not contractible in $f^{-1}(Y)$, choose a regular neighbourhood C of D with $C \cap f^{-1}(Y)$ an annulus A properly embedded in C . Let D_1, D_2 be the disks in ∂C with $\partial A = \partial D_1 \cup \partial D_2$ and let E_1, E_2 be two disjoint disks properly embedded in C with $\partial E_i = \partial D_i$. Let K_i and L_i be relative collars on E_i in C such that $K_i \cup L_i$ is a relative bicollar of E_i in C and let $D'_i \cup E'_i$ be the relative boundary of $K_i \cup L_i$ in C (see Figure 2). The spheres $(D_i - D_i \cap K_i) \cup D'_i$ ($i = 1, 2$) and $(\partial C - D_1 \cup D_2 \cup L_1 \cup L_2) \cup E'_1 \cup E'_2$ bound balls B_i and B respectively in C . Let $M'_0 = \overline{M - B_1 \cup B_2 \cup B}$ and let $g|M - \overline{C} = f|M - \overline{C}$. Since $\ker(\pi_1(Y) \rightarrow \pi_1(X)) = 1$, we may extend $g|_{\partial E_i}$ to map E_i into Y and extending g to the bicollar $K_i \cup L_i$ of E_i into the product neighbourhood of Y we obtain $g: M'_0 \rightarrow X$ as required. We have $g_* = (f|M'_0)_*$ since $f(\partial E_i) = 0$ in X .

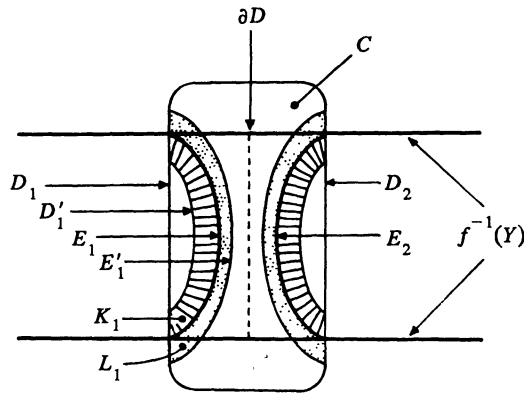

PROOF OF THEOREM 1. If $\pi_1(M) = \mathbb{Z}_2$ then both M and N are homotopy equivalent to $P^2 \times I$ and the assertion is trivial. Thus assume $\pi_1(M) \neq \mathbb{Z}_2$. Consider the map $f' = q \circ f$, where $q: M \rightarrow M'$ is the natural projection that collapses fake homotopy $P^2 \times I$'s in M onto a projective plane. Let $\mathcal{P} = \{P_1, \dots, P_m\}$ be a complete system in M' (i.e., \mathcal{P} is a pseudo-complete system in M). By Lemma 3, there are 3-balls B_1, \dots, B_k in $\text{Int } N$ such that for $N_0 = \overline{N - \cup_i B_i}$ there is a map $g: (N_0, \partial N) \rightarrow (M', \partial M)$ with $g_*: \pi_1(N_0) \rightarrow \pi_1(M')$ an isomorphism and $g^{-1}(\mathcal{P})$ a system of incompressible surfaces. We may assume that $G'(N)$ is embedded in N_0 . For each component F of $g^{-1}(\mathcal{P})$ the map $(g|_F)_*: \pi_1(F) \rightarrow \pi_1(\mathcal{P})$ is injective (for suitably chosen base points). Since $g|_{\partial N} = f|_{\partial N}$ the component F is closed and therefore F is a projective plane. Suppose that $F_{i,1}, \dots, F_{i,\alpha_i}$ are the components of $g^{-1}(F_i)$. Then all the $g_*\pi_1(F_{i,j})$ are conjugate to $\pi_1(P_i)$ in $\pi_1(M')$, and hence $\pi_1(F_{i,j})$ is conjugate to $\pi_1(F_{i,1})$ in $\pi_1(N_0)$ ($1 \leq j, l \leq \alpha_i$). Thus the nontrivial loops carried by $F_{i,1}, \dots, F_{i,\alpha_i}$ are homotopic to each other in N_0 and it follows from Theorem 4.1 of [10] that there is

a submanifold Q_i in N_0 , homotopy equivalent to a punctured $P^2 \times I$, with $\partial Q_i = F_{i,1} \cup F_{i,\alpha_i}$ and containing the other $F_{i,j}$'s in its interior. Collapsing each Q_i in N_0 to $F_{i,1}$, we obtain a quotient map $p: N_0 \rightarrow N'_0$ that induces an isomorphism on fundamental groups (but note that this N'_0 may still contain fake homotopy $P^2 \times I$'s). Again we may assume that $G'(N)$ is embedded in N'_0 . We may assume that $g|_{F_{i,j}}$ is a homeomorphism [5, Theorem 13.1]. If we collapse Q_i so that $x \in F_{i,\alpha_i}$ is identified with $(g|_{F_{i,1}})^{-1}(g|_{F_{i,\alpha_i}})(x) \in F_{i,1}$, we obtain a map $g': (N'_0, \partial N) \rightarrow (M', \partial M)$ induced by g with $g'_*: \pi_1(N'_0) \rightarrow \pi_1(M')$ an isomorphism and such that $(g')^{-1}(P_i)$ is empty or consists of one projective plane F_i in N'_0 ($i = 1, \dots, m$). Suppose $(g')^{-1}(P_i)$ is empty. If F_i does not separate M' then g' factors as $N'_0 \rightarrow M' - U(P_i) \xrightarrow{\cong} M'$ (where $U(\dots)$ is a regular neighbourhood) and i_* would be an isomorphism, which cannot be. If P_i separates M' into M'_1 and M'_2 then g' maps N'_0 into M'_1 , say, and it follows that $\pi_1(M'_2) = \mathbb{Z}_2$, hence $\partial M'_2$ consists of P_i and another projective plane P'_i , homotopic to P_i . For the nontrivial loop β of P_i , $g_*^{-1}(\beta)$ is carried by a projective plane P in N'_0 . If P is not homotopic to a boundary component then P separates (by an argument similar to the above) N'_0 into N_1 and N_2 with $\pi_1(N_1) \neq \mathbb{Z}_2$ and the isomorphism g'_* from the free product of $\pi_1(N_1)$ and $\pi_1(N_2)$ with amalgamation over $\pi_1(P)$ would induce a splitting of M'_1 over a projective plane homotopic to P_i into two submanifolds each with fundamental group different from \mathbb{Z}_2 (by Swarup [10], Theorem 5.4), which cannot be. If P is homotopic to a boundary component, by a similar argument we would get the excluded case $\pi_1(M') = \mathbb{Z}_2$.

Therefore $(g')^{-1}(P_i) = F_i$, a projective plane in N'_0 . The nontrivial loops of F_i and F_j are not homotopic in N'_0 since their images are not homotopic in M' . Therefore (again by [10]) the system $\mathbb{F} = \{F_1, \dots, F_m\}$ is a pseudo-complete system in N'_0 . Also F_i is pseudo-parallel to a boundary component of N if and only if P_i is parallel to a component of ∂M .

Now if M_j is a component of M' cut along P then $N_j = (g')^{-1}(M_j)$ is a component of N'_0 cut along \mathbb{F} . We may embed $G'(N)$ in N'_0 such that each edge intersects \mathbb{F} transversely in one point and such that g' maps each edge to an arc in M' that intersects P transversely in one point. Then for $G'(M)$ we may choose the graph $g'(C'(N))$ in M' and thus g' induces an isomorphism $G'(N) \rightarrow G'(M)$ of coloured graphs. This proves Theorem 1. \square

REMARK. We wish to thank J. Kalliongis and D. McCullough for pointing out a gap in the original proof of Theorem 1. Also it follows from their recent result (Theorem 5.1 of [12]) that Theorem 1 is in fact equivalent to Corollary 2.

If M is closed then each component of M cut along a complete system has an even number of projective planes in its boundary, since the Euler characteristic of a compact 3-manifold is even. It follows that every vertex of $G(M)$ has even degree and hence that $G(M)$ is an Euler graph (i.e. a connected graph each of whose vertices is incident to an even number of edges). Conversely, given any Euler graph G , there are infinitely many distinct, closed irreducible 3-manifolds M with $G(M)$ isomorphic to G (see [9]). It is also shown in [9] that any given graph G can be

realized as $G(M)$ for some irreducible 3-manifold M with possible compressible boundary. We strengthen this in:

THEOREM 4. For any connected graph G with a given colouring of the vertices of degree 1, there are infinitely many distinct, irreducible and ∂ -irreducible 3-manifolds M such that $G(M)$ is isomorphic to G .

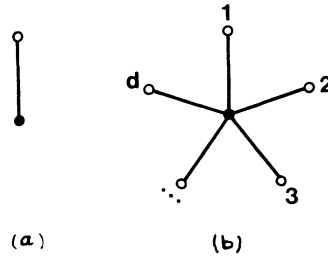

PROOF. We first construct such a 3-manifold corresponding to the graph of Figure 3(a). Let $\hat{M}_0 = S^2 \times I - \text{Int } U(k)$ and $\hat{M}_n = S^2 \times I - \text{Int } U(k \cup L)$, where U is a regular neighbourhood for the link $L = \bigcup_{i=1}^n l_i$ and the two properly embedded arcs k as shown in Figure 4. Here U is invariant under the antipodal map $\rho \times \text{id}: S^2 \times I \rightarrow S^2 \times I$. Let $g: \hat{M}_n \rightarrow M_n$ be the covering map of \hat{M}_n onto the quotient $M_n = \hat{M}_n / (\rho \times \text{id})$, then ∂M_n consists of one projective plane $g(S^2 \times 0)$, one nonorientable surface of genus 3 namely $F = g((S^2 \times 1 \cup U(k)) \cap \hat{M}_n)$, and n Klein bottles $K_i = g(\partial U(l_i) \cap \hat{M}_n)$. We claim that all boundary components of M_n are incompressible, that M_n is irreducible, and that $\{P_1^2\}$ is a complete system, where P_1^2 is a projective plane in $\text{Int } M_n$ parallel to $g(S^2 \times 0)$; it then follows that $G(M_n)$ is isomorphic to the graph of Figure 3(a).

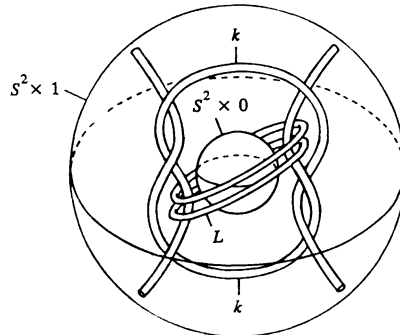

Let \hat{M}_n be obtained from \hat{M}_n by capping of $S^2 \times 0$ by a 3-ball. Lambert shows in [6] that $\partial \hat{M}_0$ is incompressible in \hat{M}_0 . Therefore $\partial \hat{M}_0$ is incompressible in M_0 and $F = g(\partial \hat{M}_0)$ is incompressible in M_0 . Now \hat{M}_0 is the complementary space of the prime tangle k (see [7]) and is in particular irreducible. To see that \hat{M}_n is irreducible, close off the components of k by arcs in $S^2 \times 1$ to get a link \hat{k} and observe that the linking number of l_i and each component of F is ± 1 . Any 2-sphere S in $\text{Int } \hat{M}_n$ separates \hat{M}_n into two components $C_j = B_j \cap \hat{M}_n$ ($j = 1, 2$),

where B_j is a 3-ball in S^3 . If l_j lies in B_1 , then so does \tilde{k} . Hence $L \cup \tilde{k} \subset B_1$ and $B_2 \cap (L \cup \tilde{k}) = \emptyset$; therefore $C_2 \cap \hat{M}_n = \emptyset$ and $C_2 = B_2$ in \hat{M}_n . It follows that any 2-sphere S in $\text{Int } \tilde{M}_n$ either bounds a 3-ball or is parallel to $S^2 \times 0$. This implies that M_n is irreducible, that $\{P_1^2\}$ is a complete system, and that each K_i is incompressible.

We now realize the graph of Figure 3(b) that consists of one vertex of degree $d \geq 2$ and d white vertices each of degree 1. Let B_i be a copy of M_1 for $i = 1, \dots, d-1$ and let B_d be a copy of M_{n+d} . Denote the Klein bottles of ∂B_i by K_i ($i = 1, \dots, n+d$). Construct the 3-manifold $B(d, n)$ from the B_j by identifying K_i with the Klein bottle of ∂B_j ($i = 1, \dots, d-1$). Since each K_i is incompressible, any 2-sided projective plane in $B(d, n)$ can be deformed off $U_i K_i$ (see e.g. [9]) and is therefore parallel to one of the projective planes of $\partial B(d, n)$. Thus $G(B(d, n))$ is isomorphic to the graph in Figure 3(b). Note that $\partial B(d, n)$ consists of n (incompressible) Klein bottles, d (incompressible) nonorientable surfaces of genus 3 and d projective planes. Note that $B(1, n) = M_n$.

Now suppose that v_1, \dots, v_k are the vertices of G of degree ≥ 2 and that among the neighbours of v_i exactly c_i are of degree 1 each. Let f_i be the number of self-loops of G based at v_i . Suppose that vertex v_i is joined to v_j by d_{ij} edges and let g_i be the sum of the d_{ij} over all neighbours v_j of v_i . Then $\deg v_i = d_i = c_i + g_i + 2f_i$. For each v_i let C_i be the 3-manifold obtained from $B(d_i, m_i)$ by identifying $2f_i$ projective planes of $\partial B(d_i, m_i)$ in pairs. Now construct a 3-manifold M' from C_1, \dots, C_k as follows: If vertex v_i is joined to v_j by d_{ij} edges in G , identify d_{ij} projective planes in ∂C_i with d_{ij} projective planes in ∂C_j . The resulting 3-manifold M' is irreducible and $\partial M'$ contains $n = m_1 + \dots + m_k$ (incompressible) Klein bottles. Now $G(M')$ is isomorphic to G , except that each vertex of degree 1 of $G(M')$ is colored white. To change the colour of such a vertex w , attach $B(1, 0)$ to M' by identifying the projective plane of M' corresponding to the vertex w with the projective plane of $\partial B(1, 0)$. In this way we construct the desired M such that $G(M) \cong G$.

Note that ∂M contains exactly n Klein bottles, where n is an arbitrary integer (independent of G). Therefore, by varying n , we have proved Theorem 4. \square

3. KLEIN BOTTLE SUM AND DEHN SURGERY

In this section, we shall show two methods to construct a P^2 -containing, irreducible, closed 3-manifold M from a P^2 -irreducible closed 3-manifold M_1 . One is a *Klein bottle sum* with $P^2 \times S^1$ and the other is a usual *Dehn surgery*. Both of them are modifications of a regular neighbourhood $U(\alpha)$ of a knot α in M_1 and are applied when $U(\alpha)$ is a solid Klein bottle or a solid torus, respectively. Lickorish's result [8] implies that any two nonorientable closed 3-manifolds can be transformed into each other by a finite sequence of Dehn surgeries along knots. However we shall show that M can be obtained from suitably chosen M_1 and α by a single Klein bottle sum with $P^2 \times S^1$ or a single Dehn surgery, as applications of the P^2 -graph $G(M)$.

Let M_1 and M_2 be two nonorientable compact 3-manifolds and let V_1 and V_2 be solid Klein bottles in $\text{Int } M_1$ and $\text{Int } M_2$, respectively. If a 3-manifold M is

obtained from $\overline{M_1 - V_1}$ and $\overline{M_2 - V_2}$ by sewing them up along the Klein bottles ∂V_1 and ∂V_2 , then M is said to be a *Klein bottle sum* of M_1 and M_2 and we write $M = M_1 \# M_2$. The homeomorphism type of M depends on a sewing map $\phi: \partial V_1 \rightarrow \partial V_2$, but is not so various. For there are only four isotopy classes of homeomorphisms of a Klein bottle. (See [8]).

Conversely, suppose that M splits into two submanifolds M'_1 and M'_2 along a 2-sided Klein bottle K^2 (i.e. $M = M'_1 \cup M'_2$, $M'_1 \cap M'_2 = K^2$). Let M_1 and M_2 denote the 3-manifolds obtained from M'_1 and M'_2 by capping off each K^2 on them with a solid Klein bottle V_i ($i = 1, 2$). Then we have a Klein bottle sum decomposition $M = M_1 \# M_2$. Since any homeomorphism of a Klein bottle extends to a homeomorphism of a solid Klein bottle [8], the homeomorphism type of M_1 and M_2 is uniquely determined, only depending on the choice of K^2 in M .

Now consider a canonical Klein bottle sum with $P^2 \times S^1$. Let V_2 be a regular neighbourhood of a nontrivial simple loop β on a fiber P^2 in $P^2 \times S^1$. Figure 5 shows that $M_2 = P^2 \times S^1 - V_2$ is a regular neighbourhood $U(P^2 \cup \alpha)$ for another fiber P^2 and a simple loop α in $P^2 \times S^1$ and is homeomorphic to $P^2 \times [0,1]$ with a 1-handle attached to both $P^2 \times 0$ and $P^2 \times 1$. Notice that the boundary of any meridian disk of V_2 runs twice through the 1-handle.

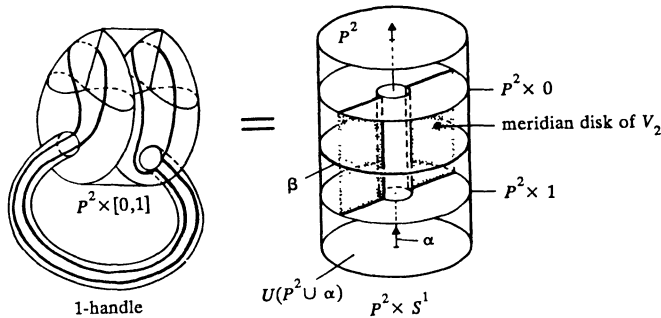

Now let M be a closed 3-manifold containing a projective plane P^2 . Since P^2 does not separate M , there is a simple loop α in M that intersects P^2 in a single point and a regular neighbourhood V of $P^2 \cup \alpha$ is homeomorphic to M_2 . Thus for $M'_1 = \overline{M - V}$ we have $M = M_1 \# P^2 \times S^1$.

By the Mayer-Vietoris exact sequence of (M_1, M_2) , we have

$$\dim H_1(M; \mathbb{Z}_2) = \dim H_1(M_1; \mathbb{Z}_2) + 1.$$

Roughly speaking, $[\alpha]$ is an extra generator for $H_1(M; \mathbb{Z}_2)$. This implies that there is a nonorientable closed 3-manifold M_1 such that M_1 contains no 2-sided projective plane and that

$$M = M_1 \# P^2 \times S^1 \# \dots \# P^2 \times S^1$$

for finitely many $P^2 \times S^1$'s.

The number of $P^2 \times S^1$'s does not exceed $\dim H_1(M_1; \mathbb{Z}_2) - 1$ since any nonorientable 3-manifold M_1 has nontrivial H_1 . Furthermore, we can decrease it to only one:

THEOREM 5. Every P^2 -containing, irreducible closed 3-manifold M can be obtained as a Klein bottle sum of a P^2 -irreducible closed 3-manifold M_1 and $P^2 \times S^1$.

$$M = M_1 \natural P^2 \times S^1.$$

PROOF. Suppose that $G(M)$ is embedded in M naturally. Since M is closed, $G(M)$ is an Euler graph. As is well-known, an Euler graph G has an Euler circuit, that is, a closed reduced edge path that contains each edge of G exactly once. Tracing an Euler circuit of $G(M)$, we can find a simple closed curve α in M which crosses each projective plane in a complete system P of M at a point. Furthermore, we make a local knot on α so that for a ball B^3 in M with $B^3 \cap \alpha$ a knotted arc, $B^3 - U(\alpha)$ contains no incompressible, ∂ -incompressible, planar surface. For example, the complements of most of the 2-bridge knots k , except torus knots, have this property [4]. So we can take the connected sum $(M, \alpha) \# (S^3, k)$ as a new α .

Let P^2 be any member of P , disjoint from B^3 . Since every 2-sided projective plane has to meet α with intersection number 1 mod 2, there is no 2-sided projective plane in M disjoint from α . Since a ball cannot contain a projective plane, if a 2-sphere S^2 in M does not meet $P^2 \cup \alpha$, then S^2 bounds a ball in M disjoint from $P^2 \cup \alpha$ by the irreducibility of M . Thus, the submanifold $M'_1 = M - U(P^2 \cup \alpha)$ is P^2 -irreducible.

Let $M_1 = M'_1 \cup V$ be the closed 3-manifold obtained from M'_1 by capping off its boundary with a solid Klein bottle V . If M_1 is not P^2 -irreducible, then there is either a 2-sided projective plane or an incompressible 2-sphere in M_1 which meets V along several meridian disks of V . Figure 5 shows that the boundary curve of a meridian disk of V must pass through B^3 twice along the local knot of α . This implies that $B^3 \cap M_1$ contains an incompressible, ∂ -incompressible, planar surface, contrary to the assumption of k . Therefore, M_1 is P^2 -irreducible and we have a decomposition $M = M_1 \natural P^2 \times S^1$. \square

We notice that M_1 in Theorem 5 cannot be taken to be universal, that is, there is no closed nonorientable 3-manifold M_1 such that every P^2 -containing closed 3-manifold M admits a Klein bottle sum decomposition $M_1 \natural P^2 \times S^1$. For if $M = M_1 \natural P^2 \times S^1$, then

$$\dim H_1(M_1; \mathbb{Z}_2) + 1 = \dim H_1(M; \mathbb{Z}_2) \geq \dim h_1(G(M); \mathbb{Z}_2).$$

The last inequality holds since there is a retraction of M onto $G(M)$. However, we can take any large value as $\dim H_1(G(M); \mathbb{Z}_2)$ by Theorem 4. Is there such a universal 3-manifold M_1 if we do not restrict the number of $P^2 \times S^1$'s?

Let α be a knot in M . A 3-manifold M_1 is called the result of a (nontrivial) *Dehn surgery* along α if M_1 can be obtained from $\overline{M - U(\alpha)}$ by sewing back $U(\alpha)$ along $\partial U(\alpha)$ in a different way. If $U(\alpha)$ is a solid Klein bottle, then any Dehn surgery does not change the homeomorphism type of M . So we shall treat only Dehn surgeries along a knot α with $U(\alpha)$ a solid torus.

By the same idea as in the proof of Theorem 5, we can show that:

THEOREM 6. Every P^2 -containing, irreducible, closed 3-manifold M contains a knot α with a regular neighbourhood $U(\alpha)$ homeomorphic to $D^2 \times S^1$ such that any nontrivial Dehn surgery along α yields a P^2 -irreducible closed 3-manifold.

PROOF. Take the same knot α as in the proof of Theorem 5. If $U(\alpha)$ is a solid Klein bottle, we add a nontrivial loop on some 2-sided projective plane to α . Then $\overline{M - U(\alpha)}$ is P^2 -irreducible. By similar arguments, we conclude that the result of a Dehn surgery along α is P^2 -irreducible whenever its surgery instruction passes through the part of the local knot of α , that is, whenever the surgery is not trivial. \square

REFERENCES

1. D.B.A. Epstein, Projective Planes in 3-manifolds, Proc. Lond. Math. Soc. (3) 11 (1961), 469-484.
2. W. Haken, Some Results on Surfaces in 3-manifolds, Studies in Modern Topology, Math. Assoc. Amer., distributed by Prentice Hall (1968), 39-98.
3. W. Heil, On P^2 -irreducible 3-manifolds, Bull. Amer. Math. Soc. 75 (1969), 772-775.
4. A. Hatcher and W. Thurston, Incompressible Surfaces in 2-bridge Knot Complements, Invent. Math. 79 (1985), 225-246.
5. J. Hempel, 3-manifolds, Ann. of Math. Studies, Vol. 86, Princeton University Press, New Jersey, 1976.
6. H.W. Lambert, Mapping Cubes with Holes onto Cubes with Handles, Ill. J. Math. 13 (1969), 606-615.
7. W.B.R. Lickorish, Prime Knots and Tangles, Trans. Amer. Math. Soc. 267 (1981), 321-332.
8. W.B.R. Lickorish, Homeomorphisms of Non-orientable Two-manifolds, Proc. Com. Phil. Soc. 59 (1963), 307-317.
9. S. Negami, Irreducible 3-manifolds with Non-trivial π_2 , Yokohama Math. J. 29 (1981), 134-144.
10. G.A. Swarup, Projective Planes in Irreducible 3-manifolds, Math. Z. 132 (1973), 305-317.
11. F. Waldhausen, On Irreducible 3-manifolds which are Sufficiently Large, Ann. of Math. 87 (1968), 56-88.
12. J. Kalliongis and D. McCullough, Maps Inducing Isomorphisms on Fundamental Groups of Compact 3-manifolds, preprint.

Special Issue on Space Dynamics

Call for Papers

Space dynamics is a very general title that can accommodate a long list of activities. This kind of research started with the study of the motion of the stars and the planets back to the origin of astronomy, and nowadays it has a large list of topics. It is possible to make a division in two main categories: astronomy and astrodynamics. By astronomy, we can relate topics that deal with the motion of the planets, natural satellites, comets, and so forth. Many important topics of research nowadays are related to those subjects. By astrodynamics, we mean topics related to spaceflight dynamics.

It means topics where a satellite, a rocket, or any kind of man-made object is travelling in space governed by the gravitational forces of celestial bodies and/or forces generated by propulsion systems that are available in those objects. Many topics are related to orbit determination, propagation, and orbital maneuvers related to those spacecrafts. Several other topics that are related to this subject are numerical methods, nonlinear dynamics, chaos, and control.

The main objective of this Special Issue is to publish topics that are under study in one of those lines. The idea is to get the most recent researches and published them in a very short time, so we can give a step in order to help scientists and engineers that work in this field to be aware of actual research. All the published papers have to be peer reviewed, but in a fast and accurate way so that the topics are not outdated by the large speed that the information flows nowadays.

Before submission authors should carefully read over the journal's Author Guidelines, which are located at <http://www.hindawi.com/journals/mpe/guidelines.html>. Prospective authors should submit an electronic copy of their complete manuscript through the journal Manuscript Tracking System at <http://mts.hindawi.com/> according to the following timetable:

Manuscript Due	July 1, 2009
First Round of Reviews	October 1, 2009
Publication Date	January 1, 2010

Lead Guest Editor

Antonio F. Bertachini A. Prado, Instituto Nacional de Pesquisas Espaciais (INPE), São José dos Campos, 12227-010 São Paulo, Brazil; prado@dem.inpe.br

Guest Editors

Maria Cecilia Zanardi, São Paulo State University (UNESP), Guaratinguetá, 12516-410 São Paulo, Brazil; cecilia@feg.unesp.br

Tadashi Yokoyama, Universidade Estadual Paulista (UNESP), Rio Claro, 13506-900 São Paulo, Brazil; tadashi@rc.unesp.br

Silvia Maria Giuliatti Winter, São Paulo State University (UNESP), Guaratinguetá, 12516-410 São Paulo, Brazil; silvia@feg.unesp.br