

Geometry of Interaction explained

Masaru Shirahata

白旗 優

Division of Mathematics, Keio University, Hiyoshi Campus
慶應義塾大学日吉数学研究室

sirahata@math.hc.keio.ac.jp

1 Introduction

The purpose of this paper is mostly expository. We first review the axiomatic framework recently proposed by Abramsky, Haghverdi and Scott [1] for Girard's Geometry of Interaction [3] in terms of traced symmetric monoidal categories. We then work out in some detail how the new proposal captures Girard's original formulation.

The Geometry of Interaction is introduced by Girard as the mathematical model of the dynamics of cut-elimination. It is formulated in terms of operator algebra, and the cut-elimination is represented by a single *execution formula*. This is very much interesting, but the intuitive meaning of this mathematical model does not seem to be perfectly clear.

Abramsky and Jagadeesan [2] proposed their own formulation of Geometry of Interaction, which is very much similar to their game semantics of linear logic. The machinery is fairly simple and clear, but the precise relationship to the original formulation is not fully explicated.

The axiomatic framework of Geometry of Interaction proposed by Abramsky, Haghverdi and Scott is supposed to fill the gap between the two formulations. In any case it gives us a very clear and intuitive picture. The framework is based on a traced symmetric monoidal category, and it yields a certain compact closed category as a model of linear combinatory algebra, covering as much as Girard's original formulation works.

The precise relationship of this framework to the original Geometry of Interaction is, however, only claimed in Abramsky, Haghverdi and Scott [1] and sketched in Haghverdi [4]. It may be obvious to them, but we find it helpful to work it out in some detail. This is what we intend to do in the present paper.

2 The axiomatic framework

2.1 Traced symmetric monoidal categories

A traced symmetric monoidal category \mathbb{C} is a symmetric monoidal category enhanced with the trace operations $\text{Tr}_{X,Y}^U(f)$ from $\mathbb{C}(X \otimes U, Y \otimes U)$ to $\mathbb{C}(X, Y)$, represented by the diagrams:

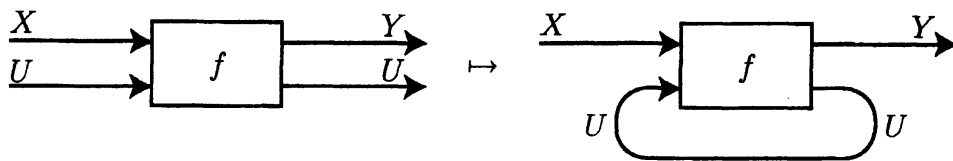

$\text{Tr}_{X,Y}^U(f)$ must satisfy the following conditions. To simplify the presentation we assume that \mathbb{C} is a strict monoidal category.

1. $\text{Tr}_{X,Y}^U(f)g = \text{Tr}_{X',Y}^U(f(g \otimes 1_U))$ for $f : X \otimes U \rightarrow Y \otimes U$ and $g : X' \rightarrow X$:

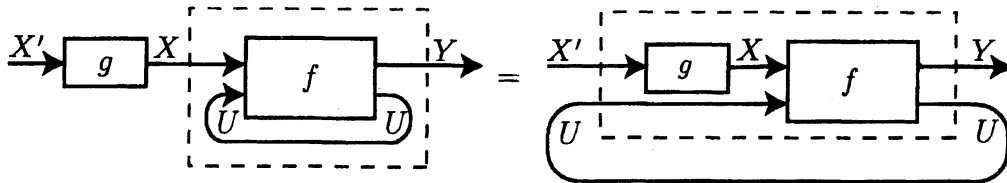

2. $g \text{Tr}_{X,Y}^U(f) = \text{Tr}_{X,Y'}^U((g \otimes 1_U)f)$ for $f : X \otimes U \rightarrow Y \otimes U$ and $g : Y \rightarrow Y'$:

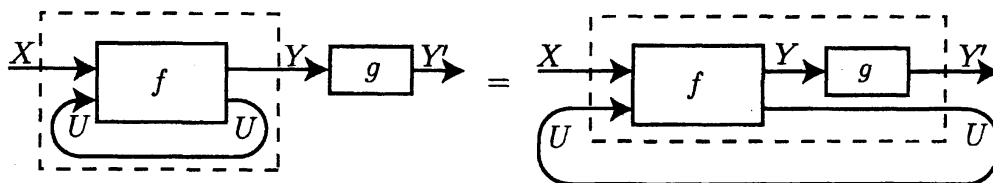

3. $\text{Tr}_{X,Y}^U((1_Y \otimes g)f) = \text{Tr}_{X,Y}^{U'}(f(1_X \otimes g))$ for $f : X \otimes U \rightarrow Y \otimes U'$ and $g : U' \rightarrow U$:

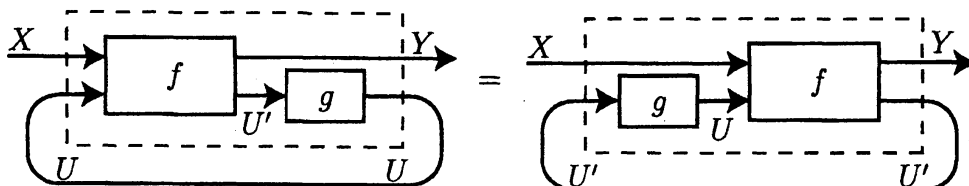

4. $\text{Tr}_{X,Y}^I(f) = f$ and $\text{Tr}_{X,Y}^{U \otimes V}(g) = \text{Tr}_{X,Y}^U(\text{Tr}_{X \otimes U, Y \otimes U}^V(g))$ for $f : X \rightarrow Y$, where $X \otimes I = X$ and $Y \otimes I = Y$, and $g : X \otimes U \otimes V \rightarrow Y \otimes U \otimes V$:

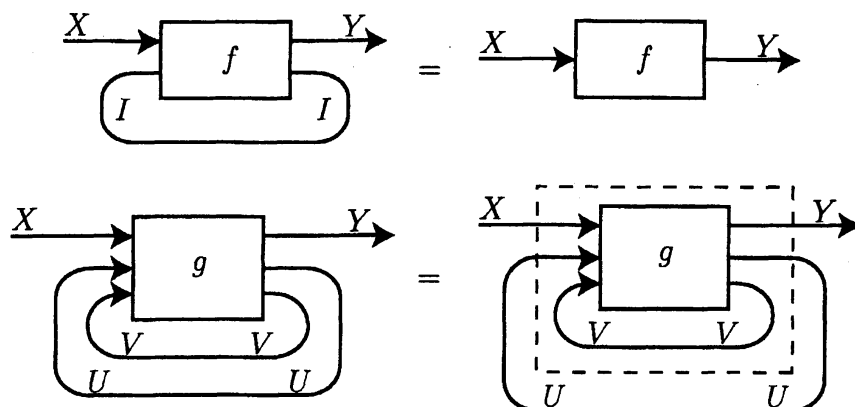

5. $g \otimes \text{Tr}_{X,Y}^U(f) = \text{Tr}_{W \otimes X, Z \otimes Y}^U(g \otimes f)$ for $f : X \otimes U \rightarrow Y \otimes U$ and $g : W \rightarrow Z$:

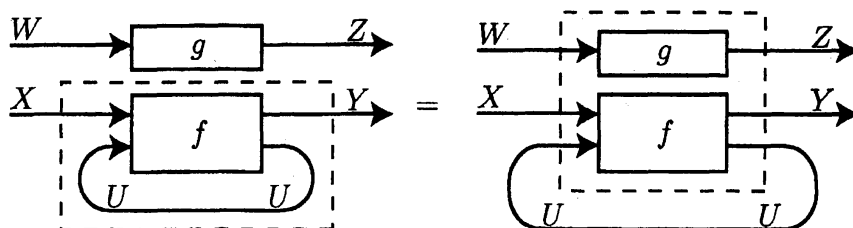

6. $\text{Tr}_{U,U}^U(\sigma_{U,U}) = 1_U$, where $\sigma_{U,U}$ is the canonical morphism for symmetry;

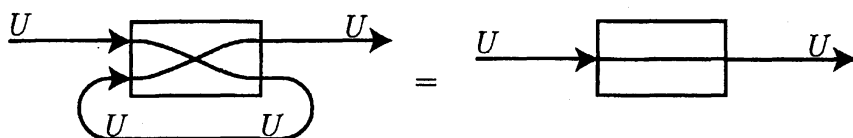

For traced symmetric monoidal categories \mathbb{C} and \mathbb{D} , a monoidal functor (F, ϕ, ϕ_I) from \mathbb{C} to \mathbb{D} is called *traced* if it is symmetric and it satisfies

$$\text{Tr}_{FX, FY}^{FU}(\phi_{Y,U}^{-1}(Ff)\phi_{X,U}) = F(\text{Tr}_{X,Y}^U(f))$$

for $f : X \otimes U \rightarrow Y \otimes U$.

2.2 The Geometry of Interaction construction

Given a traced symmetric monoidal category \mathbb{C} , we construct a compact closed category $\mathcal{G}(\mathbb{C})$, which gives a basic framework for the Geometry of Interaction.

The objects of $\mathcal{G}(\mathbb{C})$ are the pairs (A^+, A^-) of objects of \mathbb{C} . Morphisms f from (A^+, A^-) to (B^+, B^-) are the morphisms $f : A^+ \otimes B^- \rightarrow A^- \otimes B^+$ of \mathbb{C} :

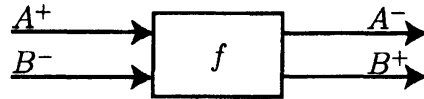

The identity for an object (A^+, A^-) is given as the canonical morphism $\sigma_{A^+, A^-} : A^+ \otimes A^- \rightarrow A^- \otimes A^+$ for symmetry in \mathbb{C} . Sometimes it is helpful to add extra subscripts to distinguish occurrences of objects. We then write $\sigma_{A^+, A^-} : A_1^+ \otimes A_2^- \rightarrow A_1^- \otimes A_2^+$ to indicate that it is a morphism from (A_1^+, A_1^-) to (A_2^+, A_2^-) .

The composition $gf : (A^+, A^-) \rightarrow (C^+, C^-)$ of morphisms $f : (A^+, A^-) \rightarrow (B^+, B^-)$ and $g : (B^+, B^-) \rightarrow (C^+, C^-)$ in $\mathcal{G}(\mathbb{C})$ is defined as

$$\text{Tr}_{A^+ \otimes C^-, A^- \otimes C^+}^{B^- \otimes B^+} (\beta(f \otimes g)\alpha)$$

in \mathbb{C} , where $\alpha = (1_{A^+} \otimes 1_{B^-} \otimes \sigma_{C^-, B^+})(1_{A^+} \otimes \sigma_{C^-, B^-} \otimes 1_{B^+})$ and $\beta = (1_{A^-} \otimes 1_{C^+} \otimes \sigma_{B^+, B^-})(1_{A^-} \otimes \sigma_{B^+, C^+} \otimes 1_{B^-})(1_{A^-} \otimes 1_{B^+} \otimes \sigma_{B^-, C^+})$, represented by the diagram:

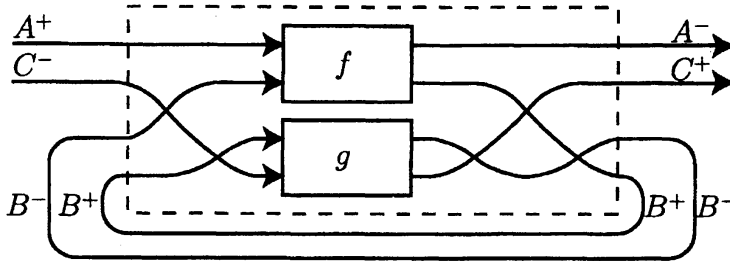

Since the coherence of the symmetric monoidal category allows us to permute the tensor products in \mathbb{C} through the canonical morphisms in any order, we can make the use of permutations implicit and depict the above diagram more intuitively:

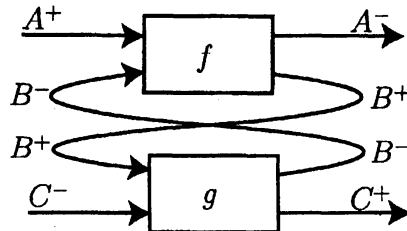

$\mathcal{G}(\mathbb{C})$ is equipped with the tensorial structure. The tensor product of (A^+, A^-) and (B^+, B^-) is given by $(A^+ \otimes B^+, A^- \otimes B^-)$, *i.e.* by taking the tensor products in \mathbb{C} pointwise. The unit is the pair (I, I) of the unit I in \mathbb{C} .

The tensor product of $f \otimes g : (A^+ \otimes C^+, B^- \otimes D^-) \rightarrow (A^- \otimes C^-, B^+ \otimes D^+)$ of $f : (A^+, A^-) \rightarrow (B^+, B^-)$ and $g : (C^+, C^-) \rightarrow (D^+, D^-)$ is given by

$$f \otimes g = (1_{A^-} \otimes \sigma_{B^+, C^-} \otimes 1_{D^+})(f \otimes g)(1_{A^+} \otimes \sigma_{C^+, B^-} \otimes 1_{D^-})$$

in \mathbb{C} , *i.e.* by taking the tensor product of f and g in \mathbb{C} and composing it with the appropriate permutations, represented by the diagram:

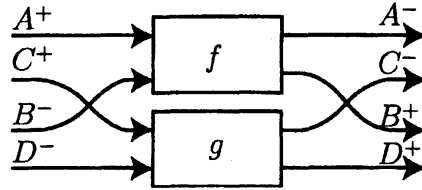

$\mathcal{G}(\mathbb{C})$ has the structure of a compact closed category as well. The left adjoint $(A^+, A^-)^*$ of (A^+, A^-) is given by (A^-, A^+) , *i.e.* by exchanging the two components. Then the unit $\eta : (I, I) \rightarrow (A^+, A^-) \otimes (A^+, A^-)^*$ should be a morphism from the unit object (I, I) to $(A^+ \otimes A^-, A^- \otimes A^+)$, which is in turn a morphism from $A^- \otimes A^+$ to $A^+ \otimes A^-$ in \mathbb{C} . In fact we can simply take σ_{A^-, A^+} in \mathbb{C} as the unit η :

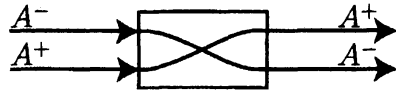

The counit $\delta : (A^+, A^-)^* \otimes (A^+, A^-) \rightarrow (I, I)$ can be similarly given by $\sigma_{A^-, A^+} : A^- \otimes A^+ \rightarrow A^+ \otimes A^-$ in \mathbb{C} .

2.3 The GoI Situation

To yield a model of intuitionistic linear logic, the traced symmetric monoidal category \mathbb{C} needs to have an extra structure, which is summarized as a GoI Situation.

Let us recall that A is a *retract* of B when there exists morphisms $f : A \rightarrow B$ and $g : B \rightarrow A$ such that $gf = 1_A$. In such a case we call (f, g) a *retraction* and write $f : A \triangleleft B : g$. The *GoI Situation* is a triple (\mathbb{C}, T, U) , where \mathbb{C} is a traced symmetric monoidal category, T is a traced symmetric monoidal functor on \mathbb{C} with the following retractions as monoidal natural transformations:

1. $e : TT \triangleleft T : e'$ (Comultiplication),
2. $d : \text{Id} \triangleleft T : d'$ (Dereliction),

3. $c : T \otimes T \triangleleft T : c'$ (Contraction),

4. $w : \mathcal{K}_I \triangleleft T : w'$ (Weakening), where \mathcal{K}_I is the constant I functor;

and U is a *reflexive object* in \mathbb{C} with the retractions:

1. $j : U \otimes U \triangleleft U : k$,

2. $l : I \triangleleft U : m$,

3. $u : TU \triangleleft U : v$.

The functor T is intended to induce the exponential operator $!$ of linear logic in $\mathcal{G}(\mathbb{C})$, as suggested by the names of the retractions.

For any categories \mathbb{C}, \mathbb{D} and functors $F, G : \mathbb{C} \rightarrow \mathbb{D}$, we say that a family of morphisms $m_A : FA \rightarrow GA$ is a *pointwise* natural transformation from F to G if the naturality condition holds only for morphisms $f : I \rightarrow A$, *i.e.* the diagram

$$\begin{array}{ccc} FA & \xrightarrow{m_A} & GA \\ Ff \uparrow & & \uparrow Gf \\ FI & \xrightarrow{m_I} & GI \end{array}$$

commutes for any such f .

Given a GoI Situation (\mathbb{C}, T, U) , the compact closed category $\mathcal{G}(\mathbb{C})$ becomes a *weakly* linear category, in the sense that the standard maps for the exponential are only pointwise natural.

This is, however, sufficient to obtain a model of intuitionistic linear logic, since we only consider the morphisms from (I, I) to (U, U) . In fact $\mathcal{G}(\mathbb{C})((I, I), (U, U))$ is a linear combinatory algebra, *i.e.*, the algebraic model of intuitionistic linear logic.

The construction of linear combinatory algebra from the GoI Situation is fully worked out in Abramsky, Haghverdi and Scot [1], and we do not give its detail here. In the present paper we are more interested in how this setting fits Girard's original formulation of Geometry of Interaction.

At this moment we only note that a morphism $f : (I, I) \rightarrow (U, U)$ in $\mathcal{G}(\mathbb{C})$ is nothing but the morphism $f : U \rightarrow U$ in \mathbb{C} , assuming that \mathbb{C} is a strict monoidal category. In this case it is more perspicuous to distinguish the two occurrences of U in (U, U) as (U^+, U^-) , and write $f : U^- \rightarrow U^+$ for f in \mathbb{C} :

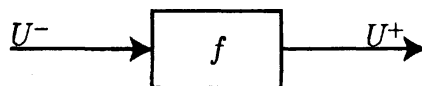

2.4 The category \mathbf{PInj}

A typical example of a traced symmetric monoidal category with a GoI Situation is the category of sets and partial injective functions. This category is equipped with the tensorial structure defined by the disjoint unions of sets and functions.

Given the disjoint union $A \uplus B = \{(0, x) \mid x \in A\} \cup \{(1, y) \mid y \in B\}$ of sets A and B , we have the injections $\iota_1 : A \rightarrow A \uplus B$ and $\iota_2 : B \rightarrow A \uplus B$ defined by

$$\iota_1 : x \mapsto (0, x), \quad \iota_2 : y \mapsto (1, y)$$

and the quasi (partial) projections $\pi_1 : A \uplus B \rightarrow A$ and $\pi_2 : A \uplus B \rightarrow B$ defined by

$$\pi_1 : (0, x) \mapsto x, \quad \pi_2 : (1, y) \mapsto y.$$

They can be naturally extended to the n -ary injections $\iota_i^n : A_i \rightarrow A_1 \uplus \dots \uplus A_n$ and quasi projections $\pi_i^n : A_1 \uplus \dots \uplus A_n \rightarrow A_i$. Note that they are all partial injective functions and hence morphisms of \mathbf{PInj} .

If partial injective functions $f_i : A \rightarrow B$ ($i \in I$) have mutually disjoint domains $\{x \mid \exists y f_i(x) = y\}$ and mutually disjoint codomains $\{y \mid \exists x f_i(x) = y\}$, they can be summed up simply by taking the union $\bigcup_{i \in I} f_i$. We write $\sum_{i \in I} f_i$ for $\bigcup_{i \in I} f_i$.

By means of ι_i^n and π_i^n any partial function $f : A_1 \uplus \dots \uplus A_n \rightarrow A_1 \uplus \dots \uplus A_m$ can be decomposed as

$$f = \sum_{i \in \{1, \dots, m\}} \sum_{j \in \{1, \dots, n\}} f_{ij}$$

where $f_{ij} = \pi_i^m f \iota_j^n$. Furthermore the trace of $f : A \oplus U \rightarrow B \oplus U$ is given by

$$\mathrm{Tr}_{A,B}^U(f) = f_{AA} + \sum_{n \in \omega} f_{UB} f_{UU}^n f_{AU}$$

where $f_{AA} = f_{11}$, $f_{AU} = f_{12}$, $f_{UB} = f_{21}$, $f_{UU} = f_{22}$.

3 Girard's formulation

3.1 The preliminary setting

Girard's original Geometry of Interaction is formulated in terms of operator algebra. The canonical example is the Banach space $\mathcal{B}(\mathbb{H})$ of bounded operators on \mathbb{H} , where \mathbb{H} is the Hilbert space ℓ^2 of square summable infinite sequences of complex numbers.

It turns out that the full internal structure of $\mathcal{B}(\mathbb{H})$ is not really necessary. For this reason we only state some of the basic definitions. The infinite sequence $\mathbf{z} = (z_i)_{i \in \omega}$ of complex numbers is *square summable* if $\sum_{i=0}^{\infty} z_i \bar{z}_i$ converges. In that

case the square root of this value is denoted $\|z\|$. The *bounded operator* u on \mathbb{H} is a linear transformation on \mathbb{H} such that $\sup\{\|u(z)\| \mid \|z\| = 1\}$ is finite.

For $\mathbf{x} = (x_i)$ and $\mathbf{y} = (y_i)$, the scalar product $\langle \mathbf{x}, \mathbf{y} \rangle$ is defined as $\sum x_i \bar{y}_i$, and we have the adjoint operation $u \mapsto u^*$ on $\mathcal{B}(\mathbb{H})$ such that $\langle u\mathbf{x}, \mathbf{y} \rangle = \langle \mathbf{x}, u^*\mathbf{y} \rangle$. A bounded operator u is

- *unitary* if $uu^* = u^*u = 1$, where 1 is the identity operator,
- *hermitian* if $u = u^*$,
- a *projector* if u is hermitian and $u^2 = u$,
- a *symmetry* if u is hermitian and unitary,
- a *partial isometry* if uu^* and u^*u are projectors.

Any projector defines a closed subspace $\mathbb{H}' = \{u\mathbf{x} \mid \mathbf{x} \in \mathbb{H}\}$ of \mathbb{H} . Conversely given any closed subspace \mathbb{H}' of \mathbb{H} , the unique decomposition $\mathbf{x} = \mathbf{x}' + \mathbf{x}''$ of $\mathbf{x} \in \mathbb{H}$ into \mathbf{x}' in \mathbb{H}' and \mathbf{x}'' in its orthogonal complement \mathbb{H}'' gives a projector $\mathbf{x} \mapsto \mathbf{x}'$.

A partial isometry u can be regarded then as a scalar product preserving map (isometry) from the subspace $\{u^*u\mathbf{x} \mid \mathbf{x} \in \mathbb{H}\}$ onto the subspace $\{uu^*\mathbf{x} \mid \mathbf{x} \in \mathbb{H}\}$. Clearly $uu^*u\mathbf{x}$ belongs to the latter, and it is onto since $uu^*\mathbf{x} = u((u^*u)(u^*\mathbf{x}))$. The scalar product is preserved since

$$\langle uu^*u\mathbf{x}, uu^*u\mathbf{y} \rangle = \langle u^*u\mathbf{x}, u^*uu^*u\mathbf{y} \rangle = \langle u^*u\mathbf{x}, u^*u\mathbf{y} \rangle$$

holds.

3.2 The partial isometries p and q

What is really necessary from $\mathcal{B}(\mathbb{H})$ is the existence of partial isometries p and q , which are used to internalize the direct sum $\mathbb{H} \oplus \mathbb{H}$ within \mathbb{H} . In fact it suffices to have any p and q such that

- (1) $p^*q = q^*p = 0$,
- (2) $p^*p = q^*q = 1$.

As a matter of fact (2) implies that p and q are partial isometries.

The concrete examples of p and q can be given by introducing the canonical base (\mathbf{b}^n) of ℓ^2 . Each $\mathbf{b}^n = (b_m^n)$ is an infinite sequence of 0 and 1 such that $b_m^n = 1$ iff $n = m$:

0	1	n
0	0	1

Clearly any $z = (z_n)$ is expressed as the infinitary linear combination $z = \sum z_n b^n$.

Then p is given by $pz = \sum z_n b^{2n}$ and its adjoint p^* by $p^*z = \sum z_{2n} b^n$:

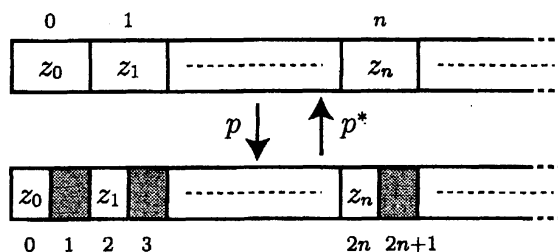

Similarly $qz = \sum z_n b^{2n+1}$ and $q^*z = \sum z_{2n+1} b^n$:

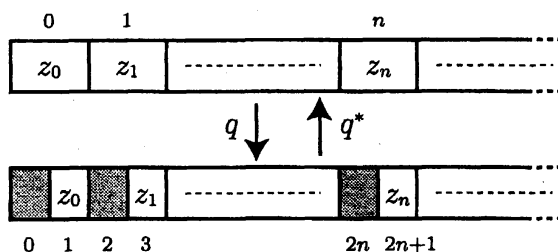

Note that p may be regarded as an isometry from $\mathbb{H} = \{p^*pz \mid z \in \mathbb{H}\}$ onto $\{\sum z_n b_{2n} \mid z_n \in \mathbb{C}\} = \{pp^*z \mid z \in \mathbb{H}\}$, hence a bijection between them. Similarly q may be regarded as a bijection between \mathbb{H} and $\{\sum z_n b_{2n+1} \mid z_n \in \mathbb{C}\}$.

In those examples of p and q the equation

$$(1') \quad pp^* + qq^* = 1$$

holds, which is stronger than (1). From (1') we have

$$p^*q = p^*(pp^* + qq^*)q = p^*pp^*q + p^*qq^*q = p^*q + p^*q$$

and $p^*q = 0$ holds. $q^*p = 0$ similarly follows from (1').

3.3 Internalizing the direct sum

The direct sum $\mathbb{H} \oplus \mathbb{H}'$ of the Hilbert spaces \mathbb{H} and \mathbb{H}' can simply given as the vector space of formal expressions $x \oplus x'$ for $x \in \mathbb{H}$ and $x' \in \mathbb{H}'$, where the vector addition and the scalar multiplication are defined pointwise, and

$$\langle x \oplus x', y \oplus y' \rangle = \langle x, y \rangle + \langle x', y' \rangle.$$

The direct sum $f \oplus g$ of morphisms f and g is defined similarly as

$$(f \oplus g)(x \oplus y) = fx \oplus gy.$$

We take $\mathbf{x} \oplus (\mathbf{y} \oplus \mathbf{z})$ to be identical to $(\mathbf{x} \oplus \mathbf{y}) \oplus \mathbf{z}$, simply denoted $\mathbf{x} \oplus \mathbf{y} \oplus \mathbf{z}$, and make the canonical isomorphisms for associativity identity maps. Recall that direct sum is just another name of biproduct in the category of vector spaces.

For $\mathbb{H} = \ell^2$, the direct sum $\mathbb{H} \oplus \mathbb{H}$ has the base consisting of $\mathbf{b}^n \oplus \mathbf{0}$ and $\mathbf{0} \oplus \mathbf{b}^n$. Then the mapping

$$\begin{cases} \mathbf{b}^n \oplus \mathbf{0} & \mapsto \mathbf{b}^{2n}, \\ \mathbf{0} \oplus \mathbf{b}^n & \mapsto \mathbf{b}^{2n+1} \end{cases}$$

induces the isomorphism $j : \mathbb{H} \oplus \mathbb{H} \rightarrow \mathbb{H}$. For $\mathbf{x} = (x_n)$ and $\mathbf{y} = (y_n)$

$$j(\mathbf{x} \oplus \mathbf{y}) = j(\mathbf{x} \oplus \mathbf{0} + \mathbf{0} \oplus \mathbf{y}) = \sum x_n \mathbf{b}^{2n} + \sum y_n \mathbf{b}^{2n+1} = p\mathbf{x} + q\mathbf{y},$$

and for $\mathbf{z} = (z_n)$

$$\begin{aligned} j^{-1}\mathbf{z} &= j^{-1}\left(\sum z_{2n} \mathbf{b}^{2n} + \sum z_{2n+1} \mathbf{b}^{2n+1}\right) \\ &= \left(\sum z_{2n} \mathbf{b}^n\right) \oplus \mathbf{0} + \mathbf{0} \oplus \left(\sum z_{2n+1} \mathbf{b}^n\right) \\ &= p^*\mathbf{z} \oplus q^*\mathbf{z}. \end{aligned}$$

Hence we can regard $p\mathbf{x} + q\mathbf{y} \in \mathbb{H}$ as the internal representation of $\mathbf{x} \oplus \mathbf{y} \in \mathbb{H} \oplus \mathbb{H}$, and any $\mathbf{z} \in \mathbb{H}$ can be regarded as such.

Given j we have the isomorphisms $1_{\mathbb{H}} \oplus j : \mathbb{H}' \oplus \mathbb{H} \oplus \mathbb{H} \rightarrow \mathbb{H}' \oplus \mathbb{H}$ and this is enough to establish the existence of isomorphism $j^n : \mathbb{H}^n \rightarrow \mathbb{H}$ for $n \geq 3$.

Under the general setting $j : \mathbf{x} \oplus \mathbf{y} \mapsto p\mathbf{x} + q\mathbf{y}$ does not necessarily give an isomorphism but constitutes a retraction with $k : \mathbf{z} \mapsto p^*\mathbf{z} \oplus q^*\mathbf{z}$. This follows immediately from the conditions (1) and (2) for p and q . It can be generalized to the retraction $j^n : \mathbb{H}^n \triangleleft \mathbb{H} : k^n$ as well.

3.4 Matrix representation of operators

\mathbb{H}^n is a biproduct, and we have the projections $\pi_i : \mathbb{H}^n \rightarrow \mathbb{H}$ ($1 \leq i \leq n$) given by

$$\mathbf{x}_1 \oplus \cdots \oplus \mathbf{x}_n \mapsto \mathbf{x}_i$$

and the injections $\iota_i : \mathbb{H} \rightarrow \mathbb{H}^n$ ($1 \leq i \leq n$) given by

$$\mathbf{x} \mapsto \mathbf{0} \oplus \cdots \oplus \underset{\substack{\uparrow \\ \text{ith}}}{\mathbf{x}} \oplus \cdots \oplus \mathbf{0}.$$

This *additive* structure allows the decomposition of a map $f : \mathbb{H}^n \rightarrow \mathbb{H}^m$ into the maps (f_{ij}) ($1 \leq i \leq m$ and $1 \leq j \leq n$) by

$$f_{ij} = \pi_i f \iota_j : \mathbb{H} \rightarrow \mathbb{H}$$

in such a way that

$$f(\mathbf{x}_1 \oplus \cdots \oplus \mathbf{x}_n) = \sum_{i=1}^n f_{1i}\mathbf{x}_i \oplus \cdots \oplus \sum_{i=1}^n f_{mi}\mathbf{x}_i.$$

Writing the direct sum $(\mathbf{x}_1 \oplus \cdots \oplus \mathbf{x}_n)$ as a column vector, we can rewrite the above formula as the familiar equation

$$\begin{pmatrix} \sum_{i=1}^n f_{1i}\mathbf{x}_i \\ \vdots \\ \sum_{i=1}^n f_{mi}\mathbf{x}_i \end{pmatrix} = \begin{pmatrix} f_{11} & \cdots & f_{1n} \\ \vdots & \ddots & \vdots \\ f_{m1} & \cdots & f_{mn} \end{pmatrix} \begin{pmatrix} \mathbf{x}_1 \\ \vdots \\ \mathbf{x}_n \end{pmatrix}$$

of matrix computation, *i.e.* the map $f : \mathbb{H}^n \rightarrow \mathbb{H}^m$ can be expressed as the matrix

$$\begin{pmatrix} f_{11} & \cdots & f_{1n} \\ \vdots & \ddots & \vdots \\ f_{m1} & \cdots & f_{mn} \end{pmatrix}$$

and this is represented graphically as:

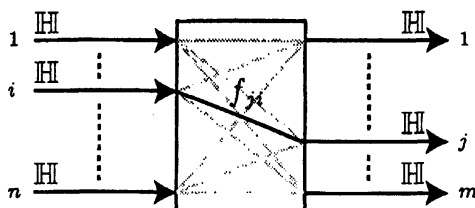

For $f : \mathbb{H}^n \rightarrow \mathbb{H}^m$ and $g : \mathbb{H}^{n'} \rightarrow \mathbb{H}^{m'}$, the direct sum $f \oplus g$ is then represented by the matrix

$$\begin{pmatrix} f_{11} & \cdots & f_{1n} & 0 & \cdots & 0 \\ \vdots & \ddots & \vdots & \vdots & \ddots & \vdots \\ f_{m1} & \cdots & f_{mn} & 0 & \cdots & 0 \\ 0 & \cdots & 0 & g_{11} & \cdots & g_{1n'} \\ \vdots & \ddots & \vdots & \vdots & \ddots & \vdots \\ 0 & \cdots & 0 & g_{m'1} & \cdots & g_{m'n'} \end{pmatrix}$$

and the diagram for $f \oplus g$ is obtained by stacking the diagrams for f and g .

Since we have the retraction (possibly isomorphism) $j^n : \mathbb{H}^n \triangleleft \mathbb{H} : k^n$, any map $f : \mathbb{H}^n \rightarrow \mathbb{H}^m$ can be regarded as the map $\hat{f} = j^m f k^n : \mathbb{H} \rightarrow \mathbb{H}$ as depicted below.

$$\begin{array}{ccc} \mathbb{H}^n & \xrightarrow{f} & \mathbb{H}^m \\ k^n \uparrow & & \downarrow j^m \\ \mathbb{H} & \xrightarrow{\hat{f}} & \mathbb{H} \end{array}$$

We call \hat{f} the *internalized version* of f . Note that f can be recovered from \hat{f} by $\hat{f} \mapsto k^m \hat{f} j^n$. Hence we can officially stay inside the endomorphisms on \mathbb{H} , while working informally on maps from \mathbb{H}^n to \mathbb{H}^m .

Similarly any map $f : \mathbb{H}^{n+2} \rightarrow \mathbb{H}^{n+2}$ ($n \geq 0$) can be regarded as the map

$$\begin{cases} (1_{\mathbb{H}^n} \oplus j)f(1_{\mathbb{H}^n} \oplus k) & \text{if } n \geq 1, \\ jfk & \text{if } n = 0, \end{cases}$$

from \mathbb{H}^{n+1} to \mathbb{H}^{n+1} . Note that

$$j = \begin{pmatrix} p & q \end{pmatrix}, \quad k = \begin{pmatrix} p^* \\ q^* \end{pmatrix}$$

and $(1_{\mathbb{H}^n} \oplus j)f(1_{\mathbb{H}^n} \oplus k)$ can be written as

$$\begin{pmatrix} 1 & \cdots & 0 & 0 & 0 \\ \vdots & \ddots & \vdots & \vdots & \vdots \\ 0 & \cdots & 1 & 0 & 0 \\ 0 & \cdots & 0 & p & q \end{pmatrix} \begin{pmatrix} f_{11} & \cdots & f_{1n} & \alpha_1 & \alpha_2 \\ \vdots & \ddots & \vdots & \vdots & \vdots \\ f_{m1} & \cdots & f_{mn} & \beta_1 & \beta_2 \\ \alpha'_1 & \cdots & \alpha'_2 & \gamma_1 & \gamma_2 \\ \beta'_1 & \cdots & \beta'_2 & \delta_1 & \delta_2 \end{pmatrix} \begin{pmatrix} 1 & \cdots & 0 & 0 \\ \vdots & \ddots & \vdots & \vdots \\ 0 & \cdots & 1 & 0 \\ 0 & \cdots & 0 & p^* \\ 0 & \cdots & 0 & q^* \end{pmatrix}$$

which is equal to the matrix:

$$\begin{pmatrix} f_{11} & \cdots & f_{1n} & \alpha_1 p^* + \alpha_2 q^* \\ \vdots & \ddots & \vdots & \vdots \\ f_{m1} & \cdots & f_{mn} & \beta_1 p^* + \beta_2 q^* \\ p\alpha'_1 + q\beta'_1 & \cdots & p\alpha'_2 + q\beta'_2 & p\gamma_1 p^* + p\gamma_2 q^* + q\delta_1 p^* + q\delta_2 q^* \end{pmatrix}$$

We write Φ for the operation $f \mapsto (1_{\mathbb{H}^n} \oplus j)f(1_{\mathbb{H}^n} \oplus k)$ or $f \mapsto jfk$, and Φ will be called *contraction* of matrices (f_{ij}) . Note that any two rows (columns) of a matrix can be exchanged by the left (right) action of the isomorphism:

$$\begin{pmatrix} 1 & & & & & \\ & \ddots & & & & \\ & & 0 & \cdots & 1 & \\ & & \vdots & \ddots & \vdots & \\ & & 1 & \cdots & 0 & \\ & & & & & \ddots & \\ & & & & & & 1 \end{pmatrix}$$

Hence we can contract any two rows and columns of a matrix by moving them last, contracting them and moving them back.

3.5 The interpretation of proofs

For now we concentrate on the multiplicative fragment of classical linear logic without exponentials.

We consider a proof together with all the cut formulas within it. A proof of a sequent $\vdash A_1, \dots, A_n$ with cut formulas B_1, \dots, B_m is said to be of type $\vdash [B_1, \dots, B_m]A_1, \dots, A_n$. It is interpreted by an $(2m + n, 2m + n)$ matrix of the elements of $\mathcal{B}(\mathbb{H})$, which is officially transposed to an element of $\mathcal{B}(\mathbb{H})$ through the retraction.

The interpretation of an axiom $\vdash A, A^\perp$ is the permutation σ :

$$\sigma = \begin{pmatrix} 0 & 1 \\ 1 & 0 \end{pmatrix}$$

Given a proof of type $\vdash [\Delta] \Gamma, A, B$ with the interpretation Π , a proof of type $\vdash [\Delta] \Gamma, A \wp B$ obtained from it by the \wp rule is interpreted just by $\Phi\Pi$, where Φ is the contraction of the last two rows and columns of a matrix.

Given proofs of type $\vdash [\Delta] \Gamma, A$ and of type $\vdash [\Delta'] \Gamma', A'$ with interpretations Π and Π'

$$\Pi = \begin{pmatrix} \Sigma & \alpha \\ \vdots & \vdots \\ \beta & \dots & \gamma \end{pmatrix}, \quad \Pi' = \begin{pmatrix} \Sigma' & \alpha' \\ \vdots & \vdots \\ \beta' & \dots & \gamma' \end{pmatrix}$$

respectively, a proof of type $\vdash [\Delta, \Delta'] \Gamma, \Gamma', A \otimes A'$ obtained from them by the \otimes rule is interpreted by

$$\Phi \begin{pmatrix} \Sigma & 0 & \boxed{\alpha} & 0 \\ \vdots & \vdots & \vdots & \vdots \\ 0 & \Sigma' & 0 & \boxed{\alpha'} \\ \vdots & \vdots & \vdots & \vdots \\ \boxed{\beta} \dots & 0 \dots & \boxed{\gamma} & 0 \\ 0 \dots & \boxed{\beta'} \dots & 0 & \boxed{\gamma'} \end{pmatrix}$$

where the matrix to be contracted is obtained by moving the last row and column of Π right before the last row and column of Π' in $\Pi \oplus \Pi'$.

Similarly given proofs of type $\vdash [\Theta] A, \Gamma$ and of type $\vdash [\Theta'] A^\perp, \Delta$ with interpretations Π and Π' as below

$$\Pi = \begin{pmatrix} \alpha & \dots & \beta \\ \vdots & \Sigma & \vdots \\ \gamma & \vdots & \vdots \end{pmatrix}, \quad \Pi' = \begin{pmatrix} \alpha' & \dots & \beta' \\ \vdots & \Sigma' & \vdots \\ \gamma' & \vdots & \vdots \end{pmatrix}$$

a proof of type $\vdash [A, \Theta, \Theta'] \Gamma, \Delta$ obtained from them by the cut rule is interpreted by the matrix:

$$\begin{pmatrix} \boxed{\alpha} & 0 & \boxed{\dots \beta} & 0 & \dots \\ 0 & \boxed{\alpha'} & 0 & \dots & \boxed{\dots \beta'} \\ \vdots & 0 & \Sigma & 0 & \\ \boxed{\gamma} & \vdots & & & \\ 0 & \boxed{\vdots} & 0 & \Sigma' & \\ \vdots & \boxed{\gamma'} & & & \end{pmatrix}$$

Note that we move the last rows and columns of Π and Π' to the first two rows and columns in $\Pi \oplus \Pi'$ and we do not apply the contraction Φ here.

3.6 The execution formula

The interpretation Π of a proof of type $\vdash [B_1, \dots, B_m] A_1, \dots, A_n$ is an $(2m+n, 2m+n)$ matrix. From this we can obtain a proof of type $\vdash A_1, \dots, A_n$ by cut elimination. This process is expressed by the *execution formula*:

$$\mathbf{Ex}(\Pi, \sigma_{m,n}) = (I_{2m+n} - \sigma_{m,n}^2) \Pi (I_{2m+n} - \sigma_{m,n} \Pi)^{-1} (I_{2m+n} - \sigma_{m,n}^2)$$

where I_{2m+n} is the unit matrix and $\sigma_{m,n}$ is given by

$$\sigma_{m,n} = \underbrace{\sigma \oplus \dots \oplus \sigma}_{m \text{ times}} \oplus 0_n$$

or

$$\sigma_{m,n} = \begin{pmatrix} 0 & 1 & \dots & 0 & 0 & & \\ 1 & 0 & \dots & 0 & 0 & & \\ \vdots & \vdots & \ddots & \vdots & \vdots & & \\ 0 & 0 & \dots & 0 & 1 & & \\ 0 & 0 & \dots & 1 & 0 & & \\ & & & 0 & & & 0 \end{pmatrix}.$$

Acting from the left $\sigma_{m,n}^2$ is the map

$$\begin{pmatrix} \mathbf{x}_1 \\ \mathbf{x}_2 \\ \vdots \\ \mathbf{x}_{2m-1} \\ \mathbf{x}_{2m} \\ \mathbf{x}_{2m+1} \\ \vdots \\ \mathbf{x}_{2m+n} \end{pmatrix} \mapsto \begin{pmatrix} \mathbf{x}_2 \\ \mathbf{x}_1 \\ \vdots \\ \mathbf{x}_{2m} \\ \mathbf{x}_{2m-1} \\ 0 \\ \vdots \\ 0 \end{pmatrix}$$

and $I_{2m+n} - \sigma_{m,n}^2$ is nothing but

$$\begin{pmatrix} \mathbf{x}_1 \\ \vdots \\ \mathbf{x}_{2m} \\ \mathbf{x}_{2m+1} \\ \vdots \\ \mathbf{x}_{2m+n} \end{pmatrix} \mapsto \begin{pmatrix} 0 \\ \vdots \\ 0 \\ \mathbf{x}_{2m+1} \\ \vdots \\ \mathbf{x}_{2m+n} \end{pmatrix}.$$

Recall that if the infinite series $I + X + X^2 + \dots$ converges for a matrix X , it is equal to the matrix $(I - X)^{-1}$. In our case the matrix $\sigma_{m,n}\Pi$ is shown to be *nilpotent*, i.e. $(\sigma_{m,n}\Pi)^i = 0_{2m+n}$ for some i . This in fact corresponds to the normalization of a proof. Hence the infinite series $I + \sigma_{m,n}\Pi + (\sigma_{m,n}\Pi)^2 + \dots$ converges and

$$\Pi(I_{2m+n} - \sigma_{m,n}\Pi)^{-1} = \Pi + \Pi\sigma_{m,n}\Pi + \Pi\sigma_{m,n}\Pi\sigma_{m,n}\Pi + \dots$$

holds.

3.7 Exponentials

The exponentials ! and ? are handled by internalizing the tensor product $\mathbb{H} \otimes \mathbb{H}'$, which is defined as the space of all linear combinations of $\mathbf{x} \otimes \mathbf{y}$ ($\mathbf{x} \in \mathbb{H}$ and $\mathbf{y} \in \mathbb{H}'$) with complex coefficients, quotiented by the equivalence relations:

$$\begin{aligned} \mathbf{x} \otimes (\mathbf{x}' + \mathbf{y}') &= \mathbf{x} \otimes \mathbf{x}' + \mathbf{x} \otimes \mathbf{y}', & (\mathbf{x} + \mathbf{y}) \otimes \mathbf{x}' &= \mathbf{x} \otimes \mathbf{x}' + \mathbf{y} \otimes \mathbf{x}' \\ (\lambda\mathbf{x}) \otimes \mathbf{x}' &= \mathbf{x} \otimes (\lambda\mathbf{x}') = \lambda(\mathbf{x} \otimes \mathbf{x}'). \end{aligned}$$

The tensor product $u \otimes v$ of bounded operators $u : \mathbb{H} \rightarrow \mathbb{H}$ and $v : \mathbb{H}' \rightarrow \mathbb{H}'$ is defined as the completion of

$$(u \otimes v)(\mathbf{x} \otimes \mathbf{y}) = u\mathbf{x} \otimes v\mathbf{y}.$$

In particular the tensor product $\mathbb{H} \otimes \mathbb{H}$, where $\mathbb{H} = \ell^2$, has the canonical base (\mathbf{c}^{mn}) . Each \mathbf{c}^{mn} is an infinite double sequence of 0 and 1 such that $\mathbf{c}^{mn}(m', n') = 1$ iff $m = m'$ and $n = n'$. We then have the isomorphism $\beta : \mathbb{H} \rightarrow \mathbb{H} \otimes \mathbb{H}$ induced from the bijection between \mathbb{N} and $\mathbb{N} \times \mathbb{N}$.

We write $\langle m, n \rangle$ for the number corresponding to an ordered pair (m, n) by the bijection between \mathbb{N} and $\mathbb{N} \times \mathbb{N}$. The internalized version of the associativity map between $\mathbb{H} \otimes (\mathbb{H} \otimes \mathbb{H})$ and $(\mathbb{H} \otimes \mathbb{H}) \otimes \mathbb{H}$ is then obtained as the map $t : \mathbb{H} \rightarrow \mathbb{H}$ induced by the bijection

$$\langle m, \langle n, p \rangle \rangle \mapsto \langle \langle m, n \rangle, p \rangle.$$

t^* is the inverse t^{-1} of t .

We also consider the bounded operators p and q on \mathbb{H} which are induced from the maps

$$n \mapsto \langle 0, n \rangle, \quad n \mapsto \langle 1, n \rangle$$

respectively. They are different from p and q previously defined, but they satisfy the conditions

1. $p^*q = q^*p = 0$,
2. $p^*p = q^*q = 1$.

Hence they can be used to obtain the retraction $j : \mathbb{H} \oplus \mathbb{H} \triangleleft \mathbb{H} : k$ by

$$j : \mathbf{x} \oplus \mathbf{y} \mapsto p\mathbf{x} + q\mathbf{y}, \quad k : \mathbf{z} \mapsto p^*\mathbf{z} \oplus q^*\mathbf{z}.$$

Note however that j and k are not isomorphisms anymore.

When a proof of the type $\vdash [\Delta] ?\Gamma, !A$ is obtained from a proof of the type $\vdash [\Delta] ?\Gamma, A$ by an application of the promotion rule, the matrix changes in the following way.

$$\begin{pmatrix} \alpha & \cdots & \beta \\ \vdots & \ddots & \vdots \\ \gamma & \cdots & \delta \end{pmatrix} \mapsto \begin{pmatrix} t(1 \otimes \alpha)t^* & \cdots & t(1 \otimes \beta) \\ \vdots & \ddots & \vdots \\ (1 \otimes \gamma)t^* & \cdots & 1 \otimes \delta \end{pmatrix}$$

For the dereliction rule from $\vdash [\Delta] \Gamma, A$ to $\vdash [\Delta] \Gamma, ?A$, we use:

$$\begin{pmatrix} \alpha & \cdots & \beta \\ \vdots & \ddots & \vdots \\ \gamma & \cdots & \delta \end{pmatrix} \mapsto \begin{pmatrix} \alpha & \cdots & \beta p^* \\ \vdots & \ddots & \vdots \\ p\gamma & \cdots & p\delta p^* \end{pmatrix}$$

where p and q are the new p and q we just defined. For the weakening from $\vdash [\Delta] \Gamma$ to $\vdash [\Delta] \Gamma, ?A$, we use:

$$\begin{pmatrix} \alpha & \cdots \\ \vdots & \ddots \end{pmatrix} \mapsto \begin{pmatrix} \alpha & \cdots & 0 \\ \vdots & \ddots & \vdots \\ 0 & \cdots & 0 \end{pmatrix}$$

For the contraction rule from $\vdash [\Delta] \Gamma, ? A, ? A$ to $\vdash [\Delta] \Gamma, ? A$, we change the matrix

$$\begin{pmatrix} \dots\dots\dots & \alpha_1 & \alpha_2 \\ \vdots & \ddots & \vdots & \vdots \\ \alpha'_1 & \dots & \gamma_1 & \gamma_2 \\ \beta'_1 & \dots & \delta_1 & \delta_2 \end{pmatrix}$$

to the matrix:

$$\begin{pmatrix} \dots\dots\dots\dots\dots\dots & \alpha_1(p^* \otimes 1) + \alpha_2(q^* \otimes 1) \\ \vdots & \vdots \\ (p \otimes 1)\alpha'_1 + (q \otimes 1)\beta'_1 & \dots & (p \otimes 1)\gamma_1(p^* \otimes 1) + (p \otimes 1)\gamma_2(q^* \otimes 1) \\ & & + (q \otimes 1)\delta_1(p^* \otimes 1) + (q \otimes 1)\delta_2(q^* \otimes 1) \end{pmatrix}$$

4 Working out the relationship

4.1 The category \mathbf{Hilb}_2

In this section we work out how the axiomatic framework captures Girard’s original formulation, following Haghverdi’s sketch in [4]. The category we are working with is not the category of Hilbert spaces but its subcategory \mathbf{Hilb}_2 defined by M. Barr.

The key observation is that there exists a monoidal contravariant functor, called ℓ^2 , from the category \mathbf{PInj} to the category of Hilbert spaces. A set X is mapped to the space of those complex valued functions a on X which are *square summable* in the sense that $\sum_{x \in X} |a(x)|^2$ is finite. A quasi injective function $f : X \rightarrow Y$ is mapped to the function which sends $a \in \ell^2(Y)$ to

$$\ell^2(f)(x) = \begin{cases} af(x) & \text{if } f(x) \text{ is defined} \\ 0 & \text{otherwise.} \end{cases}$$

The category \mathbf{Hilb}_2 is defined as the image of ℓ^2 .

It is known that $\ell^2(X \times Y) \cong \ell^2 X \otimes \ell^2 Y$ and $\ell^2(X \uplus Y) \cong \ell^2 X \oplus \ell^2 Y$ where $\ell^2 X \otimes \ell^2 Y$ and $\ell^2 X \oplus \ell^2 Y$ are a tensor product and a direct sum, respectively, in the category of Hilbert spaces. In \mathbf{Hilb}_2 they are both tensor products, but $\ell^2 X \oplus \ell^2 Y$ is no longer a direct sum.

The trace in \mathbf{Hilb}_2 can simply defined from the trace in \mathbf{PInj} as below.

$$\text{Tr}_{\ell^2(X), \ell^2(Y)}^{\ell^2(U)}(\ell^2(f)) = \ell^2(\text{Tr}_{X,Y}^U(f)).$$

4.2 The basic structure

A proof of $\vdash [C_1, \dots, C_m] A_1, \dots, A_n$ is interpreted by a $(2m + n, 2m + n)$ matrix, understood as an operator from \mathbb{H}^{2m+n} to \mathbb{H}^{2m+n} , which can be further internalized as an operator on \mathbb{H} .

In particular the interpretation of an axiom $\vdash A, A^\perp$, which is σ , is nothing but the canonical morphism for symmetry in \mathbf{Hilb}_2 as we expected. The linear logic tensor and par are both interpreted as the direct sum in the category of Hilbert spaces.

4.3 Cut as composition in $\mathcal{G}(\mathbf{Hilb}_2)$

Cut in a sequent calculus corresponds to composition in a category. Consider proofs Π and Π' of sequents $\vdash A, \Gamma$ and $\vdash A^\perp, \Delta$, respectively. In our setting they are interpreted as the morphisms $\Pi : (I, I) \rightarrow (A^+, A^-) \oplus (\Gamma^+, \Gamma^-)$ and $\Pi' : (I, I) \rightarrow (A^-, A^+) \oplus (\Delta^+, \Delta^-)$ in $\mathcal{G}(\mathbf{Hilb}_2)$. Since we are in a compact closed category, we can obtain the desired morphism by the composition with the counit

$$\delta : (A^+, A^-) \otimes (A^-, A^+) \rightarrow (I, I)$$

in the following way:

$$(I, I) \xrightarrow{\Pi \otimes \Pi'} (A^+, A^-) \oplus (\Gamma^+, \Gamma^-) \oplus (A^-, A^+) \oplus (\Delta^+, \Delta^-) \rightarrow$$

$$(\Gamma^+, \Gamma^-) \oplus (\Delta^+, \Delta^-) \oplus (A^+, A^-) \oplus (A^-, A^+) \xrightarrow{1 \otimes \delta} (\Gamma^+, \Gamma^-) \oplus (\Delta^+, \Delta^-).$$

This morphism is depicted by the diagram:

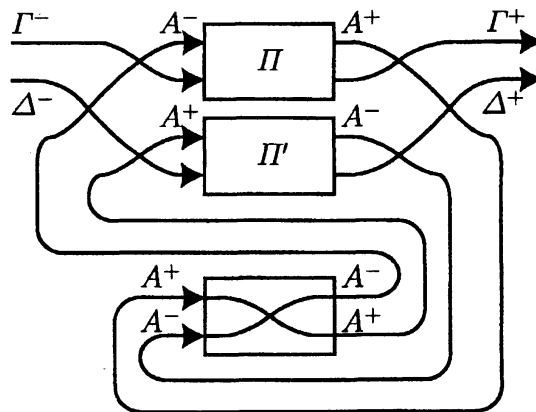

which can be simplified to the following.

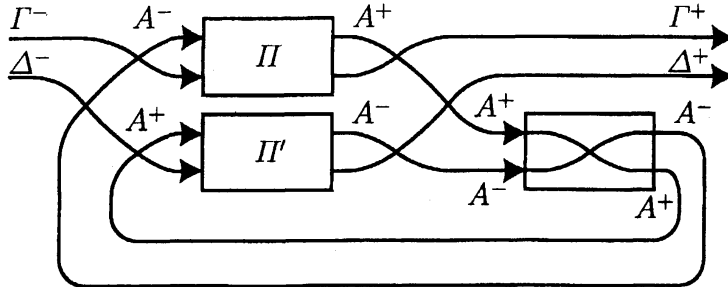

Although we adopt the convention to take the trace at the right component U of the products $X \oplus U$ and $Y \oplus U$, the permutation allows us to formulate the trace at the left component U of $U \oplus X$ and $U \oplus Y$ as well. Using the latter convention we can represent the morphism $\widehat{\Pi}$

$$(I, I) \xrightarrow{\widehat{\Pi}} (A_1^+, A_1^-) \oplus (A_1^-, A_1^+) \oplus \cdots \oplus (A_m^+, A_m^-) \oplus (A_m^-, A_m^+) \oplus (\Gamma^+, \Gamma^-) \xrightarrow{\delta \oplus \cdots \oplus \delta \oplus 1} (\Gamma^+, \Gamma^-)$$

by the following diagram:

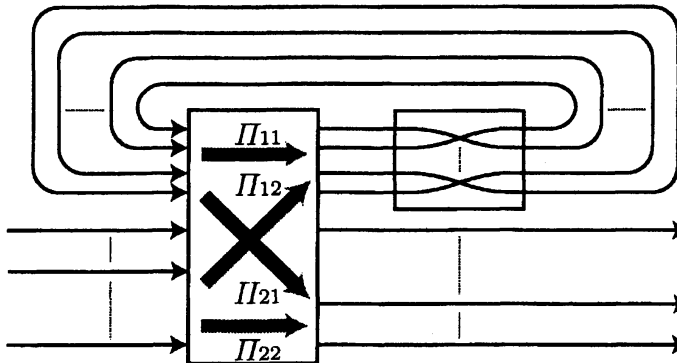

where $\Pi_{11}, \Pi_{12}, \Pi_{21}$ and Π_{22} are obtained as the submatrices of the matrix Π as below:

$$\Pi = \left(\begin{array}{cc|cc} f_{11} & \cdots & f_{12m} & \\ \vdots & \ddots & \vdots & \\ f_{2m1} & \cdots & f_{2m2m} & \\ \hline f_{2m+11} & \cdots & f_{2m+12m} & \\ \vdots & \ddots & \vdots & \\ f_{2m+n1} & \cdots & f_{2m+n2m} & \end{array} \right) = \begin{pmatrix} \Pi_{11} & \Pi_{12} \\ \Pi_{21} & \Pi_{22} \end{pmatrix}$$

$\widehat{\Pi}$ is the morphism which corresponds to the proof Π of the type $\vdash [A_1, \dots, A_m] \Gamma$.
Writing

$$\begin{cases} \widehat{\sigma} = \underbrace{\sigma \oplus \dots \oplus \sigma}_{m \text{ times}} \\ \widehat{\sigma}_{m,n} = \widehat{\sigma} \oplus 1_n, \end{cases}$$

we can express $\widehat{\Pi}$ by the formula

$$\begin{aligned} \widehat{\Pi} &= \Pi_{22} + \sum_{n=0}^{\infty} \Pi_{21} (\widehat{\sigma} \Pi_{11})^n \widehat{\sigma} \Pi_{12} \\ &= \Pi_{22} + \Pi_{21} \widehat{\sigma} \Pi_{12} + \Pi_{21} (\widehat{\sigma} \Pi_{11}) \widehat{\sigma} \Pi_{12} + \Pi_{21} (\widehat{\sigma} \Pi_{11}) (\widehat{\sigma} \Pi_{11}) \widehat{\sigma} \Pi_{12} + \dots \\ &= \text{Tr}_{\Gamma^-, \Gamma^+}^{A_1 \oplus \dots \oplus A_m} (\widehat{\sigma}_{m,n} \Pi), \end{aligned}$$

where $\widehat{\sigma}_{m,n} \Pi$ is the matrix:

$$\widehat{\sigma}_{m,n} \Pi = \begin{pmatrix} \widehat{\sigma} \Pi_{11} & \widehat{\sigma} \Pi_{12} \\ \Pi_{21} & \Pi_{22} \end{pmatrix}$$

Furthermore by way of the projection

$$\alpha : \begin{pmatrix} x_1 \\ \vdots \\ x_{2m} \\ x_{2m+1} \\ \vdots \\ x_{2m+n} \end{pmatrix} \mapsto \begin{pmatrix} x_{2m+1} \\ \vdots \\ x_{2m+n} \end{pmatrix}$$

and the injection

$$\alpha' : \begin{pmatrix} x_{2m+1} \\ \vdots \\ x_{2m+n} \end{pmatrix} \mapsto \begin{pmatrix} 0 \\ \vdots \\ 0 \\ x_{2m+1} \\ \vdots \\ x_{2m+n} \end{pmatrix}$$

we have

$$\begin{aligned} \alpha \text{Ex}(\pi, \sigma_{m,n}) \alpha' &= \alpha \Pi \alpha' + \alpha \Pi \sigma_{m,n} \Pi \alpha' + \alpha \Pi \sigma_{m,n} \Pi \sigma_{m,n} \Pi \alpha' + \dots \\ &= \Pi_{22} + \Pi_{21} \widehat{\sigma} \Pi_{12} + \Pi_{21} (\widehat{\sigma} \Pi_{11}) \widehat{\sigma} \Pi_{12} + \dots \\ &= \widehat{\Pi}. \end{aligned}$$

4.4 Exponentials from a GoI Situation

The exponential operator $!$ is modelled by the functor

$$\mathbb{X} \mapsto \mathbb{H} \otimes \mathbb{X}, \quad f \mapsto 1_{\mathbb{H}} \otimes f$$

where $\mathbb{H} \otimes \mathbb{X}$ is the tensor product in Hilbert spaces.

We then need to check that the GoI Situation holds with $T = \mathbb{H} \otimes \text{Id}$ and $U = \mathbb{H}$. The retractions for a reflexive object U become

1. $j : \mathbb{H} \oplus \mathbb{H} \triangleleft \mathbb{H} : k$,
2. $l : I \triangleleft \mathbb{H} : m$,
3. $u : \mathbb{H} \otimes \mathbb{H} \triangleleft \mathbb{H} : v$.

in the present situation.

We have already seen that p and q give us the retraction $j : \mathbb{H} \oplus \mathbb{H} \triangleleft \mathbb{H} : k$ by

$$j : \mathbf{x} \oplus \mathbf{y} \mapsto p\mathbf{x} + q\mathbf{y}, \quad k : \mathbf{z} \mapsto p^*\mathbf{z} \oplus q^*\mathbf{z}.$$

Recall however that there are many possibilities to choose specific p and q , and j and k may or may not become isomorphisms depending on the choice.

The additive unit object I is obtained as $\ell^2(\emptyset)$, which is indeed the singleton $\{\emptyset\}$. Clearly

$$l : \mathbf{0} \mapsto \mathbf{0}, \quad m : \mathbf{x} \mapsto \mathbf{0}$$

give us the required retraction $l : I \triangleleft \mathbb{H} : m$.

For $u : \mathbb{H} \otimes \mathbb{H} \triangleleft \mathbb{H} : v$ we have already seen the existence of an isomorphism $\beta : \mathbb{H} \rightarrow \mathbb{H} \otimes \mathbb{H}$. Hence $v = \beta$ and $u = \beta^{-1}$ suffice.

The retractions for the functor T are

1. $e : TT \triangleleft T : e'$ (Comultiplication),
2. $d : \text{Id} \triangleleft T : d'$ (Dereliction),
3. $c : T \oplus T \triangleleft T : c'$ (Contraction),
4. $w : \mathcal{K}_I \triangleleft T : w'$ (Weakening)

where $T : X \mapsto \mathbb{H} \otimes X$, $f \mapsto 1 \otimes f$.

The retraction $e : TT \triangleleft T : e'$ is obtained as follows.

$$e : \mathbb{H} \otimes (\mathbb{H} \otimes \mathbb{X}) \xrightarrow{a} (\mathbb{H} \otimes \mathbb{H}) \otimes \mathbb{X} \xrightarrow{\beta^{-1} \otimes 1} \mathbb{H} \otimes \mathbb{X}, \quad e' = e^{-1}.$$

where a is a canonical associativity map.

When $\mathbb{X} = \mathbb{H}$ we the following diagram commutes:

$$\begin{array}{ccccc}
 \mathbb{H} \otimes (\mathbb{H} \otimes \mathbb{H}) & \xrightarrow{a} & (\mathbb{H} \otimes \mathbb{H}) \otimes \mathbb{H} & \xrightarrow{\beta^{-1} \otimes 1} & \mathbb{H} \otimes \mathbb{H} \\
 \uparrow 1 \otimes \beta & & \downarrow \beta^{-1} \otimes 1 & & \parallel \\
 \mathbb{H} \otimes \mathbb{H} & & \mathbb{H} \otimes \mathbb{H} & & \mathbb{H} \otimes \mathbb{H} \\
 \uparrow \beta & & \downarrow \beta^{-1} & & \downarrow \beta^{-1} \\
 \mathbb{H} & \xrightarrow{t} & \mathbb{H} & \xlongequal{\quad} & \mathbb{H}
 \end{array}$$

Hence t is in fact the internal version of e . Similarly t^* is the internal version of e' .

For the retraction $d : \text{Id} \triangleleft T : d'$ consider the Hilbert space $\mathbb{I} = \{a \mid a : 1 \rightarrow \mathbb{C}\}$. Clearly $\mathbb{I} = \ell^2(1)$ and the isomorphism $X \times 1 \cong 1 \times X \cong X$ in \mathbf{PInj} induces the isomorphisms $\ell^2(X) \otimes \mathbb{I} \cong \mathbb{I} \otimes \ell^2(X) \cong \ell^2(X)$ in \mathbf{Hilb}_2 . We have the partial injection

$$X \longrightarrow 1 \times X \xrightarrow{(0 \mapsto 0) \times 1} \mathbb{N} \times X$$

and this induces our d . Similarly

$$\mathbb{N} \times X \xrightarrow{(0 \mapsto 0) \times 1} 1 \times X \longrightarrow X$$

induces d . For $X = \mathbb{N}$ the internal versions of d and d' coincide with our new p and p^* respectively, since the following diagrams commute:

$$\begin{array}{ccccc}
 \mathbb{H} & \xrightarrow{d} & \mathbb{H} \otimes \mathbb{H} & & \mathbb{H} \otimes \mathbb{H} & \xrightarrow{d'} & \mathbb{H} \\
 \parallel & & \downarrow \beta^{-1} & & \uparrow \beta & & \parallel \\
 \mathbb{H} & \xrightarrow{p} & \mathbb{H} & & \mathbb{H} & \xrightarrow{p^*} & \mathbb{H}
 \end{array}$$

The retraction $c : T \oplus T \triangleleft T : c'$ is obtained through the isomorphism

$$(\ell^2(X) \oplus \ell^2(Y)) \otimes \ell^2(Z) \cong (\ell^2(X) \otimes \ell^2(Z)) \oplus (\ell^2(Y) \otimes \ell^2(Z))$$

in \mathbf{Hilb}_2 induced from the isomorphism $(X \uplus Y) \times Z \cong (X \times Z) \uplus (Y \times Z)$ in \mathbf{PInj} . The map c is

$$(\mathbb{H} \otimes \mathbb{X}) \oplus (\mathbb{H} \otimes \mathbb{X}) \longrightarrow (\mathbb{H} \oplus \mathbb{H}) \otimes \mathbb{X} \xrightarrow{j \otimes 1} \mathbb{H} \otimes \mathbb{X},$$

and c' is

$$\mathbb{H} \otimes \mathbb{X} \xrightarrow{k \otimes 1} (\mathbb{H} \oplus \mathbb{H}) \otimes \mathbb{X} \longrightarrow (\mathbb{H} \otimes \mathbb{X}) \oplus (\mathbb{H} \otimes \mathbb{X}).$$

We then have

$$\begin{aligned}
 c((\mathbf{x} \otimes \mathbf{z}) \oplus (\mathbf{y} \otimes \mathbf{w})) &= (j \otimes 1)((\mathbf{x} \oplus \mathbf{0}) \otimes \mathbf{z} + (\mathbf{0} \oplus \mathbf{y}) \otimes \mathbf{w}) \\
 &= p\mathbf{x} \otimes \mathbf{z} + q\mathbf{y} \otimes \mathbf{w} \\
 &= (p \otimes 1)(\mathbf{x} \otimes \mathbf{z}) + (q \otimes 1)(\mathbf{y} \otimes \mathbf{w})
 \end{aligned}$$

and

$$\begin{aligned} c'(\mathbf{x} \otimes \mathbf{y}) &= (p^* \mathbf{x} \otimes \mathbf{y}) \oplus (q^* \mathbf{x} \otimes \mathbf{y}) \\ &= (p^* \otimes 1)(\mathbf{x} \otimes \mathbf{y}) \oplus (q^* \otimes 1)(\mathbf{x} \otimes \mathbf{y}). \end{aligned}$$

The retraction $w : \mathcal{K}_I \triangleleft T : w'$ is obtained by

$$w : \mathbf{0} \mapsto \mathbf{0}, \quad w' : \mathbf{x} \otimes \mathbf{y} \mapsto \mathbf{0}.$$

Those retraction maps give the promotion, dereliction, contraction and weakening maps in $\mathcal{G}(\text{Hilb}_2)$.

The promotion map $!(A^+, A^-) \rightarrow !!(A^+, A^-)$ is the one depicted by the diagram:

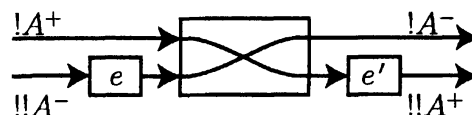

The interpretation of a proof obtained by an application of the promotion rule is given by the composition with this morphism, and the result can be depicted as follows:

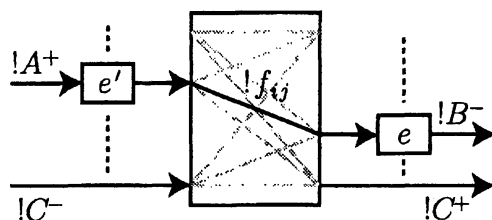

Since the internalized versions of e and e' are t and t^* , respectively, this in fact gives the matrix:

$$\begin{pmatrix} t(1 \otimes \alpha)t^* & \cdots & t(1 \otimes \beta) \\ \vdots & \ddots & \vdots \\ (1 \otimes \gamma)t^* & \cdots & 1 \otimes \delta \end{pmatrix}$$

The dereliction map $!(A^+, A^-) \rightarrow (A^+, A^-)$ is:

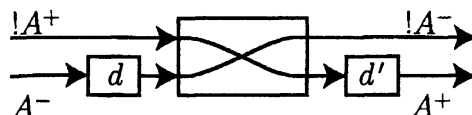

and the composition with this map yields:

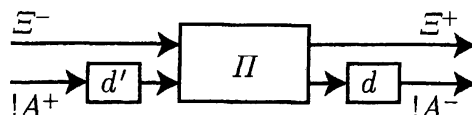

The internalized versions of d and d' are p and p^* , respectively. Hence we have the matrix:

$$\begin{pmatrix} \alpha & \cdots & \beta p^* \\ \vdots & \ddots & \vdots \\ p\gamma & \cdots & p\delta p^* \end{pmatrix}$$

The contraction map $!(A^+, A^-) \rightarrow !(A^+, A^-) \oplus !(A^+, A^-)$ is:

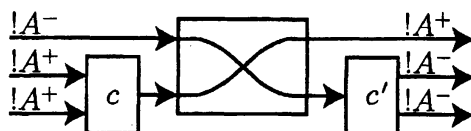

and the composition gives:

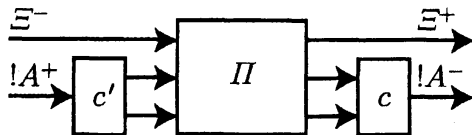

Since we are writing the direct sum $\mathbf{x} \oplus \mathbf{y}$ as a column vector, $c : \mathbf{x} \oplus \mathbf{y} \mapsto (p \otimes 1)\mathbf{x} + (q \otimes 1)\mathbf{y}$ and $c' : \mathbf{x} \mapsto (p^* \otimes 1)\mathbf{x} \oplus (q^* \otimes 1)\mathbf{x}$ are represented by the matrices:

$$c = (p \otimes 1 \quad q \otimes 1), \quad c' = \begin{pmatrix} p^* \otimes 1 \\ q^* \otimes 1 \end{pmatrix}$$

Hence the proof obtained by an application of the contraction rule is represented by the following matrix as we expected:

$$\begin{pmatrix} \dots\dots\dots & \alpha_1(p^* \otimes 1) + \alpha_2(q^* \otimes 1) \\ \vdots & \vdots \\ (p \otimes 1)\alpha'_1 + (q \otimes 1)\beta'_1 & \dots & (p \otimes 1)\gamma_1(p^* \otimes 1) + (p \otimes 1)\gamma_2(q^* \otimes 1) \\ & & + (q \otimes 1)\delta_1(p^* \otimes 1) + (q \otimes 1)\delta_2(q^* \otimes 1) \end{pmatrix}$$

The weakening map $!(A^+, A^-) \rightarrow (I, I)$ is:

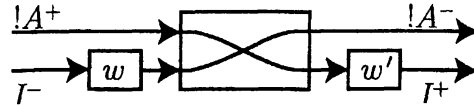

and the interpretation of a proof is:

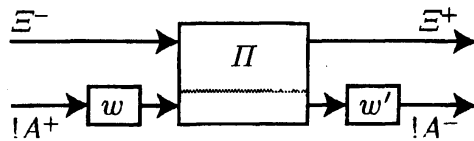

whose matrix is

$$\begin{pmatrix} \alpha & \cdots \\ \vdots & \ddots \end{pmatrix} \mapsto \begin{pmatrix} \alpha & \cdots & 0 \\ \vdots & \ddots & \vdots \\ 0 & \cdots & 0 \end{pmatrix}$$

since w and w' are the constant zero operators.

5 Discussion on the naturality

It has been shown in [1] that the promotion, dereliction, contraction and weakening maps in $\mathcal{G}(\mathbb{C})$ become natural transformations iff the corresponding retraction maps are isomorphisms. The argument can be easily generalized and we now state and prove its generalized version.

Let (S, ϕ, ϕ_I) and (T, ψ, ψ_I) be monoidal functors on \mathbb{C} . Suppose that we have a family of retractions $h : SA \triangleleft TA : h'$ which is a monoidal natural transformation from S to T . Consider a family of morphisms in $\mathcal{G}(\mathbb{C})$ which have the form:

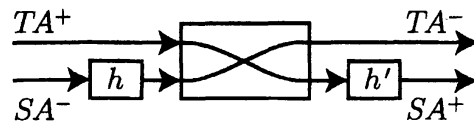

Such a family of morphisms becomes a natural transformation in $\mathcal{G}(\mathbb{C})$ iff $hh' = 1_{TA}$ for all objects A in \mathbb{C} .

We give a proof as a sequence of diagrams. When we precompose such a morphism to another morphism Sf we obtain the morphism represented by the diagram

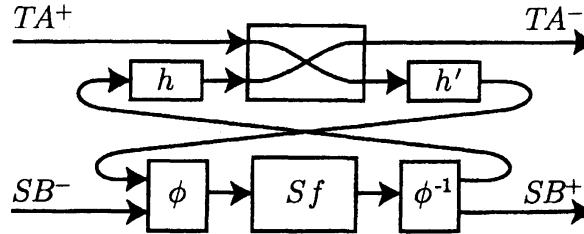

where $\phi : SA^+ \otimes SB^- \rightarrow S(A^+ \otimes B^-)$ is the isomorphism provided by the monoidal functor S . This diagram can be simplified to:

$$\begin{array}{c}
 \begin{array}{ccccccc}
 TA^+ & & & & & & TA^- \\
 \rightarrow & \boxed{h'} & \rightarrow & \boxed{\phi} & \rightarrow & \boxed{Sf} & \rightarrow & \boxed{\phi^{-1}} & \rightarrow & \boxed{h} & \rightarrow & TA^- \\
 SB^- & & & & & & & & & & & SB^+
 \end{array} \\
 \end{array} \tag{1}$$

Similarly when we postcompose the morphism to Tf we obtain:

$$\begin{array}{c}
 \begin{array}{ccccccc}
 TA^+ & & & & & & TA^- \\
 \rightarrow & \boxed{h} & \rightarrow & \boxed{\psi} & \rightarrow & \boxed{Tf} & \rightarrow & \boxed{\psi^{-1}} & \rightarrow & \boxed{h'} & \rightarrow & TA^- \\
 SB^- & & & & & & & & & & & SB^+
 \end{array} \\
 \end{array} \tag{2}$$

where $\psi : TA^+ \otimes TB^- \rightarrow T(A^+ \otimes B^-)$ is the isomorphism provided by T .

The naturality is the claim that the diagrams (1) and (2) always represent the same morphism. To see when it holds, we first insert $h'h$, which is an identity since (h, h') is a retraction, in the diagram (1) as follows:

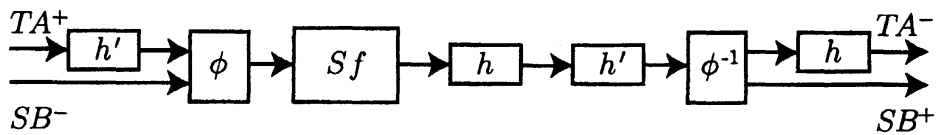

The naturality of h then allows us to transform it to the below:

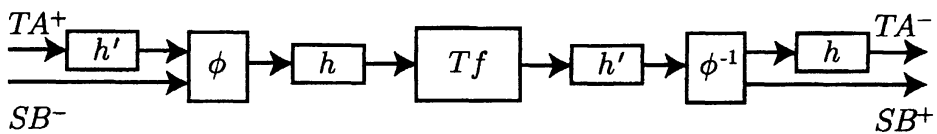

Since h and h' are monoidal natural transformations, we can then make the diagram (1) in the following form:

$$\begin{array}{c}
 \begin{array}{ccccccc}
 TA^+ & & & & & & TA^- \\
 \rightarrow & \boxed{h'} & \rightarrow & \boxed{h} & \rightarrow & \boxed{\psi} & \rightarrow & \boxed{Tf} & \rightarrow & \boxed{\psi^{-1}} & \rightarrow & \boxed{h'} & \rightarrow & \boxed{h} & \rightarrow & TA^- \\
 SB^- & & & & & & & & & & & \boxed{h'} & \rightarrow & \boxed{h'} & \rightarrow & SB^+
 \end{array} \\
 \end{array} \tag{3}$$

If $hh' = 1_{TA}$ the diagram (3) immediately becomes the same as the diagram (2) and the naturality holds. For the other direction let $f = 1_{A \otimes B}$. Then (2) becomes the map $1_{TA} \otimes 1_{SB}$ and (3) becomes $hh' \otimes 1_{SB}$. If the naturality holds we have $1_{TA} \otimes 1_{SB} = hh' \otimes 1_{SB}$ for any objects A and B in \mathcal{C} . In particular we can choose $I = B$. Then $SB = I$ and the naturality of the isomorphisms $\lambda_A : A \otimes I \rightarrow A$ makes the following diagrams commute.

$$\begin{array}{ccc}
 TA \otimes I & \xleftarrow{\lambda_{TA}^{-1}} & TA \\
 1_{TA} \otimes 1_I \downarrow & & \downarrow 1_{TA} \\
 TA \otimes I & \xrightarrow{\lambda_{TA}} & TA
 \end{array}
 \qquad
 \begin{array}{ccc}
 TA \otimes I & \xleftarrow{\lambda_{TA}^{-1}} & TA \\
 hh' \otimes 1_I \downarrow & & \downarrow hh' \\
 TA \otimes I & \xrightarrow{\lambda_{TA}} & TA
 \end{array}$$

Hence $1_{TA} \otimes 1_I = hh' \otimes 1_I$ implies $1_{TA} = hh'$.

The naturality of the promotion, dereliction, contraction and weakening maps is necessary to make the Geometry of Interaction interpretation sound for the full cut-elimination. In Girard's original formulation, the soundness for the cases involving exponentials is obtained only when the context formulas are empty. This is due to the fact that the maps for exponentials are only pointwise natural in $\mathcal{G}(\mathbf{Hilb}_2)$.

The result stated in this section, however, tells us that we should not expect more than the pointwise naturality in this setting. We can make the retractions for contraction and promotion isomorphic, but the retractions for dereliction and weakening should not be isomorphic. As shown in [4] and [1], the pointwise naturality suffices to construct a linear combinatory algebra, which is good for the analysis of computation. If the purpose of the Geometry of Interaction is the analysis of the cut-elimination or the analysis of classical logic, however, the situation is not quite satisfactory.

The machinery of the Geometry of Interaction, either in its original formulation or the axiomatic framework, is very much symmetric. It seems however that the exponential rules, in particular dereliction and weakening, require us to re-introduce asymmetry in one way or another.

References

- [1] S. Abramsky, E. Haghverdi and P. Scott, "Geometry of Interaction and linear combinatory algebra," *Mathematical Structures in Computer Science* (2002), vol. 12, pp. 625-665.
- [2] S. Abramsky and R. Jagadeesan, "New Foundations for the Geometry of Interaction," *Proceedings 7th Annual IEEE Symp. on Logic in Computer Science, LICS'92*, Santa Cruz, CA, USA, 22-25 June 1992.

- [3] J. Y. Girard, Geometry of Interaction I: Interpretation of system F, *Logic Colloquium '88*, Ferro, Bonotto, Valentini and Zarnado (Editors), Elsevier (North-Holland), 1989, pp. 221-260.
- [4] E. Haghverdi, "Unique decomposition categories, Geometry of Interaction and combinatory logic," *Mathematical Structures in Computer Science* (2000), vol. 10, pp. 205-231.