

Singularities of Tangent Surfaces and Generalised Frontals

Goo Ishikawa
 Department of Mathematics, Hokkaido University, Japan.

1 Introduction

In this survey article we give expositions about the recent researches for the generic singularities which appear on tangent surfaces in various geometric frameworks. Actually we give the review of the recent paper [19] with the results appeared in [15][16][17][18].

Given a curve in Euclidean 3-space $\mathbf{E}^3 = \mathbf{R}^3$, the embedded tangent lines to the curve draw a surface in \mathbf{R}^3 , which is called the **tangent surface** (or **tangent developable**) to the curve.

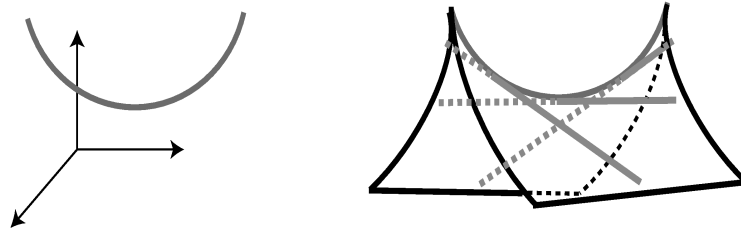

It is known that the tangent surfaces (tangent developables) are developable surfaces. Developable surfaces which are locally isometric to the plane keep on interesting many mathematicians, for instance, Monge (1764), Euler (1772), Cayley (1845), Lebesgue (1899). See [23] for details. Therefore the tangent surfaces are regarded as generalised solutions (with singularities) of the Monge-Ampère equation

$$\frac{\partial^2 z}{\partial x^2} \frac{\partial^2 z}{\partial y^2} - \left(\frac{\partial^2 z}{\partial x \partial y} \right)^2 = 0$$

on spacial surfaces $z = z(x, y)$. This property is related to “projective duality”: *The projective dual of a tangent surface collapse to a curve (the dual curve)*. See [11].

Let $\gamma : \mathbf{R} \rightarrow \mathbf{R}^3$ be an immersed curve. Then the tangent surface has the natural parametrization

$$\text{Tan}(\gamma) : \mathbf{R}^2 \rightarrow \mathbf{R}^3, \quad \text{Tan}(\gamma)(t, s) := \gamma(t) + s\gamma'(t).$$

The tangent surface necessarily has singularities at least along γ , “the edge of regression”.

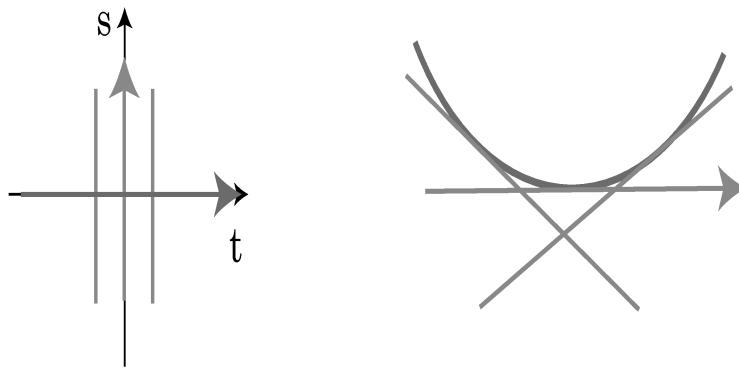

Example 1.1 Let $\gamma : \mathbf{R} \rightarrow \mathbf{R}^3$, $\gamma(t) = (t, t^2, t^3)$. Then the tangent surface $\text{Tan}(\gamma) : \mathbf{R}^2 \rightarrow \mathbf{R}^3$ is given by $\text{Tan}(\gamma) = \gamma(t) + s\gamma'(t) = (t + s, t^2 + 2st, t^3 + 3st^2)$. For the Jacobi matrix we have

$$J_F = \begin{pmatrix} 1 & 1 \\ 2t + 2s & 2t \\ 3t^2 + 6st & 3t^2 \end{pmatrix} \sim \begin{pmatrix} 0 & 1 \\ 2s & 2t \\ 6st & 3t^2 \end{pmatrix}$$

and we have $\text{rank } J_F < 2$ if and only if $s = 0$. Take the transversal $\{x_1 = 0\}$, then, $s = -t$, and we have $x_2 = -t^2, x_3 = -2t^3$, the planar cusp.

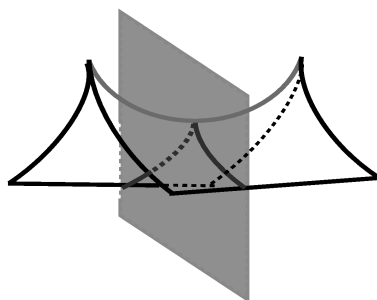

It is known that the tangent surface to a generic curve $\gamma : \mathbf{R} \rightarrow \mathbf{R}^3$ in \mathbf{R}^3 has singularities only along γ and is locally diffeomorphic to the cuspidal edge or to the folded umbrella (also called, the cuspidal cross cap), as is found by Cayley and Cleave (1980). Cuspidal edge singularities appear along ordinary points where $\gamma', \gamma'', \gamma'''$ are linearly independent, while the folded umbrellas appear at isolated points of zero torsion where $\gamma', \gamma'', \gamma'''$ are linearly dependent but $\gamma', \gamma'', \gamma''''$ are linearly independent.

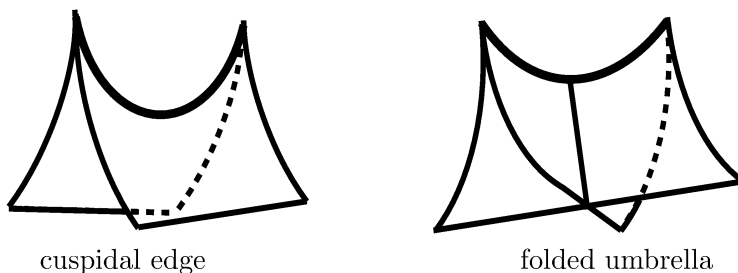

cuspidal edge

folded umbrella

The diffeomorphism equivalence is given by the commutative diagram:

$$\begin{array}{ccc} (\mathbf{R}^2, (t_0, s_0)) & \xrightarrow{F} & (\mathbf{R}^3, F(t_0, s_0)) \\ \wr \downarrow & \circlearrowleft & \wr \downarrow \\ (\mathbf{R}^2, (t_1, s_1)) & \xrightarrow{G} & (\mathbf{R}^3, G(t_1, s_1)) \end{array}$$

More degenerate singularities of tangent surfaces are classified by Mond, Arnold, Scherbak... See [11].

In a higher dimensional space \mathbf{R}^m , $m \geq 4$, for an immersed curve $\gamma : \mathbf{R} \rightarrow \mathbf{R}^m$, we define the tangent surface $\text{Tan}(\gamma) : \mathbf{R}^2 \rightarrow \mathbf{R}^m$ by $\text{Tan}(\gamma)(t, s) := \gamma(t) + s\gamma'(t)$. Then we have generically that $\gamma', \gamma'', \gamma'''$ are linearly independent and $\text{Tan}(\gamma)$ is locally diffeomorphic to the (embedded) cuspidal edge in \mathbf{R}^m . See [14].

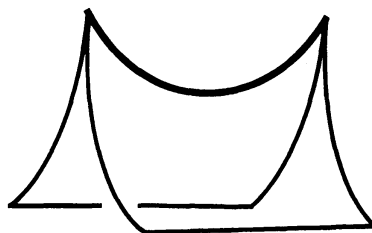

(embedded) cuspidal edge

A (not necessarily immersed) C^∞ curve $\gamma : \mathbf{R} \rightarrow \mathbf{R}^m$ is called **directed** if there exists a frame $u : \mathbf{R} \rightarrow \mathbf{R}^m$, $u(t) \neq 0$, such that

$$\gamma'(t) \in \langle u(t) \rangle_{\mathbf{R}}, t \in \mathbf{R}.$$

It is the projection of a C^∞ curve $\tilde{\gamma} : \mathbf{R} \rightarrow PTR^m$ satisfying

$$\gamma'(t) \in \tilde{\gamma}(t), (t \in \mathbf{R}),$$

where

$$PTR^m = \{(x, \ell) \mid x \in \mathbf{R}^m, \ell \subset T_x \mathbf{R}^m, \dim(\ell) = 1\}$$

is the manifold consisting of all tangential lines.

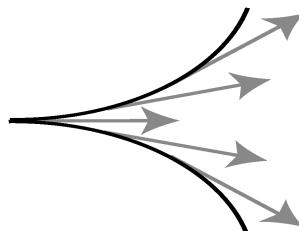

A directed curve $t \mapsto (t^2, t^3, t^4)$ in \mathbf{R}^3 .

Then the tangent surface $\text{Tan}(\gamma) : \mathbf{R}^2 \rightarrow \mathbf{R}^m$ of a directed curve γ is defined by

$$\text{Tan}(\gamma)(t, s) := \gamma(t) + s u(t)$$

The right equivalence class of $\text{Tan}(\gamma)$ is independent of the choice of frame u .

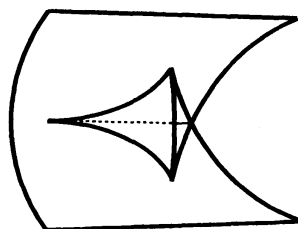

Tangent surface $\text{Tan}(\gamma)$ of the directed curve.

Then we have

Theorem 1.2 ([14]) *The singularities of the tangent surface $\text{Tan}(\gamma)$ for a generic directed curve $\gamma : \mathbf{R} \rightarrow \mathbf{R}^m$ on a neighbourhood of the curve are only the cuspidal edge, the folded umbrella, and swallowtail if $m = 3$, and the embedded cuspidal edge and the open swallowtail if $m \geq 4$.*

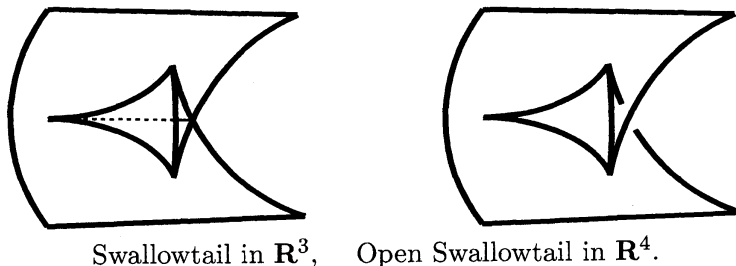

Swallowtail in \mathbf{R}^3 , Open Swallowtail in \mathbf{R}^4 .

The notion of tangent surfaces ruled by “tangent lines” to directed curves is naturally generalised in various ways:

- For a curve in a projective space, regard tangent projective lines as “tangent lines”.
- For a curve in a Riemannian manifold, regard tangent geodesics as “tangent lines”.
- For a null curve of a semi (pseudo)-Riemannian manifold, regard tangent lines by null geodesics.
- For a horizontal curve of a sub-Riemannian manifold, regard tangent lines by abnormal geodesics.

2 A_n -geometry

We would like to show generalisations (or specialisations) to the cases with additional geometric structures. In the paper [18], we have given a series of classification results of singularities of tangent surfaces in D_n -geometry, i.e. the geometry associated with the group $O(n, n)$ preserving . In this occasion we will give a series of classification results of singularities of tangent surfaces in A_n -geometry, i.e. the geometry associated to the group $\text{PGL}(n + 1, \mathbf{R})$.

Let $V = \mathbf{R}^{n+1}$ be the vector space of dimension $n + 1$ and consider a flag in V of the following type (a complete flag):

$$V_1 \subset V_2 \subset V_3 \subset \cdots \subset V_n \subset V, \quad \dim(V_i) = i.$$

The set of such flags form a manifold of dimension $\frac{n(n+1)}{2}$.

A one-parameter family of flags (a curve on the flag manifold)

$$V_1(t) \subset V_2(t) \subset V_3(t) \subset \cdots \subset V_n(t) \subset V$$

is called **admissible** if the infinitesimal movement of $V_1(t)$ at t_0 belongs to $V_2(t_0)$, the infinitesimal movement of $V_2(t)$ at t_0 belongs to $V_3(t_0)$ and so on, for any t_0 .

A curve in the projective space $P(V) = P(V^{n+1})$ arises an admissible curve if we regard its osculating planes: the curve itself is given by $V_1(t)$, the tangent line is given by $V_2(t)$, the osculating plane is given by $V_3(t)$ and so on.

We can define a distribution (a differential system) on the flag manifold such that a curve on the flag manifold is admissible if and only if the curve is an integral curve to that distribution. The distribution is one of Cartan’s canonical distributions defined from simple Lie algebras, the central objects for the theory by Noboru Tanaka after E. Cartan.

Let $n = 2$. Let $V_1(t) \subset V_2(t) \subset V = \mathbf{R}^3$ be an admissible curve. For each t_0 , planes V_2 satisfying $V_1(t_0) \subset V_2 \subset V$ form the tangent line to the curve $\{V_1(t)\}$ at $t = t_0$ in $P(V) = P^2$. Similarly lines V_1 satisfying $V_1 \subset V_2(t_0)$ form the tangent line to the dual curve $\{V_2(t)\}$ at $t = t_0$ in $\text{Gr}(2, V) = P(V^*) = P^{2*}$, the dual projective plane. For a generic admissible curve, we have the duality on “tangent maps”:

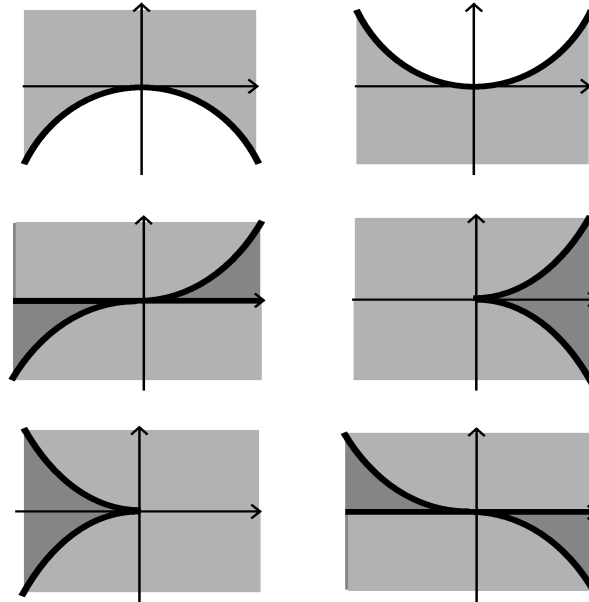

Let $n = 3$. Let $V_1(t) \subset V_2(t) \subset V_3(t) \subset V = \mathbf{R}^4$ be an admissible curve. It induces a curve in $P^3 = P(\mathbf{R}^4)$, a curve in $\text{Gr}(2, \mathbf{R}^4)$ and a curve in $P^{3*} = \text{Gr}(3, \mathbf{R}^4)$ naturally. Then we have the following duality on their “tangent surfaces”, which are ruled by tangent lines defined naturally by the flags:

③	④	③
Cuspidal Edge	Cuspidal Edge	Cuspidal Edge
Swallow Tail	Cuspidal Edge	Folded Umbrella
Mond Surface	Open Swallowtail	Mond Surface
Folded Umbrella	Cuspidal Edge	Swallow Tail

For a generic admissible curve

$$V_1(t) \subset V_2(t) \subset V_3(t) \subset \dots \subset V_n(t) \subset V,$$

we have the classification of singularities of tangent surfaces:

Theorem 2.1 ($A_n, n \geq 4$) *The classification list consists of $n + 1$ cases for curves in Grassmannians:*

P^n	$\text{Gr}(2, V)$	$\text{Gr}(3, V)$	$\text{Gr}(4, V)$	\dots	$\text{Gr}(n, V)$
CE	CE	CE	CE	\dots	CE
OSW	CE	CE	CE	\dots	CE
OM	OSW	CE	CE	\dots	OFU
OFU	CE	OSW	CE	\dots	OM
CE	CE	CE	OSW	\dots	CE
\vdots	\vdots	\vdots	\vdots	\ddots	\vdots
CE	CE	CE	CE	\dots	OSW

The **cuspidal edge** (resp. **open swallowtail**, **open Mond surface**, **open folded umbrella**) is defined as a diffeomorphism class of the tangent surface-germ to a curve of type $(1, 2, 3, \dots)$ (resp. $(2, 3, 4, 5, \dots)$, $(1, 3, 4, 5, \dots)$, $(1, 2, 4, 5, \dots)$) in an affine space. Their normal forms are given as follows:

$$\begin{aligned} \text{CE} & : (\mathbf{R}^2, 0) \rightarrow (\mathbf{R}^m, 0), \quad m \geq 3, \\ & (u, t) \mapsto (u, t^2 - 2ut, 2t^3 - 3ut^2, 0, \dots, 0). \end{aligned}$$

$$\begin{aligned} \text{OSW} & : (\mathbf{R}^2, 0) \rightarrow (\mathbf{R}^m, 0), \quad m \geq 4, \\ & (u, t) \mapsto (u, t^3 - 3ut, t^4 - 2ut^2, 3t^5 - 5ut^3, 0, \dots, 0). \end{aligned}$$

$$\begin{aligned} \text{OM} & : (\mathbf{R}^2, 0) \rightarrow (\mathbf{R}^m, 0), \quad m \geq 4, \\ & (u, t) \mapsto (u, 2t^3 - 3ut^2, 3t^4 - 4ut^3, 4t^5 - 5ut^4, 0, \dots, 0). \end{aligned}$$

$$\begin{aligned} \text{OFU} & : (\mathbf{R}^2, 0) \rightarrow (\mathbf{R}^m, 0), \quad m \geq 4, \\ & (u, t) \mapsto (u, t^2 - 2ut, 3t^4 - 4ut^3, 4t^5 - 5ut^4, 0, \dots, 0). \end{aligned}$$

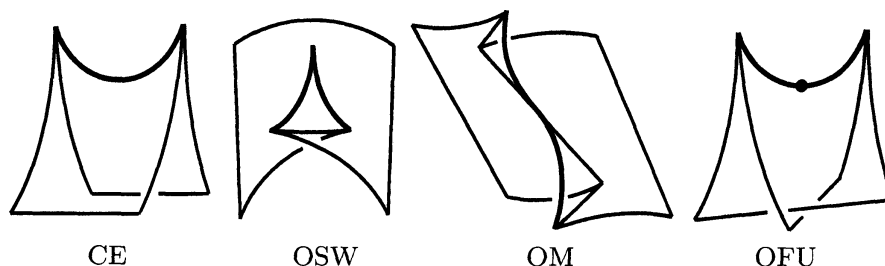

The “stability” of the classification lists of singularities for flags of type A_n when $n \rightarrow \infty$ (from $n \geq 4$) is observed.

3 Affine connection and tangent surface

Now let us consider the case of directed curves in a Riemannian manifold, or more generally, the case of directed curves in a manifold with any affine connection, which is not necessarily projectively flat. For any directed curve, we have the well-defined tangent geodesic to each point of the curve. If we regard it as the “tangent line”, then we have the well-defined tangent surface for the directed curve.

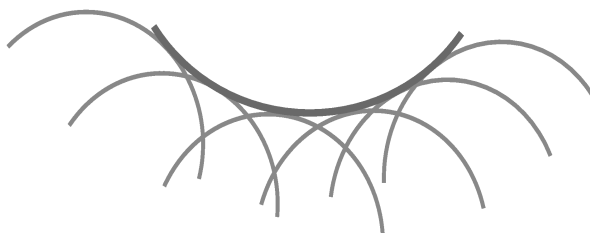

Theorem 3.1 ([19]) *For any affine connection on a manifold of dimension $m \geq 3$, the singularities of the tangent surface to a generic directed curve on a neighbourhood of the curve are only the cuspidal edge, the folded umbrella, and swallowtail if $m = 3$, and the embedded cuspidal edge and the open swallowtail if $m \geq 4$.*

Theorem 3.2 ([19])

Let ∇ be any torsion-free affine connection on a manifold M . Let $\gamma : \mathbf{R} \rightarrow M$ be a C^∞ curve.

(1) Let $\dim(M) = 3$. If $(\nabla\gamma)(t_0), (\nabla^2\gamma)(t_0), (\nabla^3\gamma)(t_0)$ are linearly independent at $t = t_0 \in \mathbf{R}$, then the tangent surface $\text{Tan}(\gamma)$ is locally diffeomorphic to the cuspidal edge at $(t_0, 0) \in \mathbf{R}^2$. If $(\nabla\gamma)(t_0), (\nabla^2\gamma)(t_0), (\nabla^3\gamma)(t_0)$ are linearly dependent, and $(\nabla\gamma)(t_0), (\nabla^2\gamma)(t_0), (\nabla^4\gamma)(t_0)$ are linearly independent, then the tangent surface $\text{Tan}(\gamma)$ is locally diffeomorphic to the folded umbrella at $(t_0, 0) \in \mathbf{R}^2$. If $(\nabla\gamma)(t_0) = 0$ and $(\nabla^2\gamma)(t_0), (\nabla^3\gamma)(t_0), (\nabla^4\gamma)(t_0)$ are linearly independent, then the tangent surface $\text{Tan}(\gamma)$ is locally diffeomorphic to the swallowtail at $(t_0, 0) \in \mathbf{R}^2$.

(2) Let $\dim(M) \geq 4$. If $(\nabla\gamma)(t_0), (\nabla^2\gamma)(t_0), (\nabla^3\gamma)(t_0)$ are linearly independent at $t = t_0 \in \mathbf{R}$, then the tangent surface $\text{Tan}(\gamma)$ is locally diffeomorphic to the embedded cuspidal edge at $(t_0, 0) \in \mathbf{R}^2$. If $(\nabla\gamma)(t_0) = 0$ and

$$(\nabla^2\gamma)(t_0), (\nabla^3\gamma)(t_0), (\nabla^4\gamma)(t_0), (\nabla^5\gamma)(t_0)$$

are linearly independent at $t = t_0 \in \mathbf{R}$, then the tangent surface $\text{Tan}(\gamma)$ is locally diffeomorphic to the open swallowtail at $(t_0, 0) \in \mathbf{R}^2$.

4 Degeneracy type of a curve

Let $\gamma : \mathbf{R} \rightarrow M$ be a C^∞ curve and $t_0 \in I$. Define

$$a_1 := \inf \left\{ k \mid k \geq 1, (\nabla^k\gamma)(t_0) \neq 0 \right\}.$$

Note that γ is an immersion at t_0 if and only if $a_1 = 1$. If $a_1 < \infty$, then define

$$a_2 := \inf \left\{ k \mid \text{rank} \left((\nabla\gamma)(t_0), (\nabla^2\gamma)(t_0), \dots, (\nabla^k\gamma)(t_0) \right) = 2 \right\}.$$

We have $1 \leq a_1 < a_2$. If $a_i < \infty, 1 \leq i < \ell \leq m$, then define a_ℓ inductively by

$$a_\ell := \inf \left\{ k \mid \text{rank} \left((\nabla\gamma)(t_0), (\nabla^2\gamma)(t_0), \dots, (\nabla^k\gamma)(t_0) \right) = \ell \right\}.$$

If $a_m < \infty$, then we call the strictly increasing sequence (a_1, a_2, \dots, a_m) of natural numbers the **type** of γ at t_0 .

In the generic cases, types for curves uniquely determine the local diffeomorphism classes of tangent surfaces.

Singularity of tangent surface	Type of curve
cuspidal edge	(1, 2, 3)
embedded cuspidal edge	(1, 2, 3, ...)
folded umbrella	(1, 2, 4)
open folded umbrella	(1, 2, 4, 5, ...)
swallowtail	(2, 3, 4)
open swallowtail	(2, 3, 4, 5, ...)

5 Generalised frontals

Definition 5.1 Let $n \leq m = \dim(M)$. A C^∞ map-germ $f : (\mathbf{R}^n, p) \rightarrow M$ is called a **frontal**, in a generalised sense, if there exists a C^∞ frame $V_1, V_2, \dots, V_n : (\mathbf{R}^n, p) \rightarrow TM$ along f and a C^∞ function-germ $\sigma : (\mathbf{R}^n, p) \rightarrow \mathbf{R}$ such that

$$\left(\frac{\partial f}{\partial t_1} \wedge \frac{\partial f}{\partial t_2} \wedge \dots \wedge \frac{\partial f}{\partial t_n} \right)(t) = \sigma(t)(V_1 \wedge V_2 \wedge \dots \wedge V_n)(t),$$

as germs of n -vector fields $(\mathbf{R}^n, p) \rightarrow \wedge^n TM$ over f . Here t_1, t_2, \dots, t_n are coordinates on (\mathbf{R}^n, p) .

For $n = 1$, a frontal was called a directed curve.

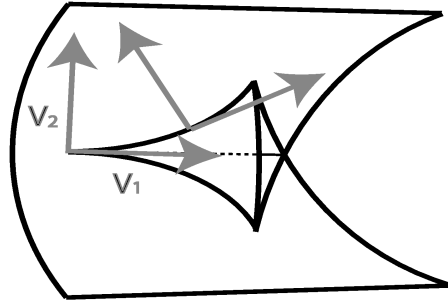
A frame of swallowtail in \mathbf{R}^3 .

The singular locus (non-immersive locus) $S(f)$ of f coincides with the zero locus $\{\sigma = 0\}$ of σ . We call σ a **signed area density function** or briefly an **s -function** of the frontal f associated with the frame. We say that frontal $f : (\mathbf{R}^n, p) \rightarrow M$ has a **non-degenerate** singular point at p if the signed area density function σ of f satisfies that $\sigma(p) = 0$ and $d\sigma(p) \neq 0$. The condition is independent of the choice of V_1, V_2, \dots, V_n and σ . If f has a non-degenerate singular point at p , then f is of corank 1 such that the singular locus $S(f) \subset (\mathbf{R}^n, p)$ is a regular hypersurface. The above notions are generalisations of those introduced in the case $n = 2, \dim(M) = 3$ by Kokubu, Rossman, Saji, Umehara, Yamada (2005) and Fujimori, Saji, Umehara, Yamada (2008).

The following is one the keys to show the above theorems:

Proposition 5.2 *Let $\gamma : \mathbf{R} \rightarrow M$ be a C^∞ curve, $t_0 \in \mathbf{R}$, and $k \geq 1$. Suppose that $(\nabla^i \gamma)(t_0) = 0, 1 \leq i < k$ and that $(\nabla^k \gamma)(t_0), (\nabla^{k+1} \gamma)(t_0)$ are linearly independent. Then the germ of tangent surface $\text{Tan}(\gamma)$ is a frontal with non-degenerate singular point at $(t_0, 0)$ and with the singular locus $S(\nabla\text{-Tan}(\gamma)) = \{s = 0\}$. Moreover $\text{Tan}(\gamma)$ is diffeomorphic to an “opening” of a plane-to-plane map-germ $(\mathbf{R}^2, 0) \rightarrow (\mathbf{R}^2, 0)$ of Thom-Boardman type $\Sigma^{1^k, 0}$.*

We also need the characterisation of swallowtails (resp. the characterisation of cuspidal cross caps (folded umbrella)) found by Kokubu, Rossman, Saji, Umehara, Yamada (2005) (resp. Fujimori, Saji, Umehara, Yamada (2008)).

We briefly give the coordinate-free characterisations of cuspidal edge and cuspidal cross cap by Fujimori, Saji, Umehara, Yamada (2008).

Let $f : (\mathbf{R}^2, p) \rightarrow M^3$ be a frontal with a non-degenerate singular point p with a frame V_1, V_2 . Take an annihilator $L : (\mathbf{R}^2, p) \rightarrow T^*M \setminus \zeta$ of V_1, V_2 , a kernel field $\eta : (\mathbf{R}^2, p) \rightarrow TM$ of the differential f_* , and a parametrisation $c : (\mathbf{R}, t_0) \rightarrow (\mathbf{R}^2, p)$ of the singular locus $S(f)$. Suppose $V_2(p) \notin f_*(T_p \mathbf{R}^2)$. Then define

$$\psi(t) = \langle L(c(t), (\nabla_\eta^f V_2)(c(t))) \rangle.$$

In terms of the function ψ , the characterisations are given:

f is diffeomorphic to the cuspidal edge if and only if $\psi(t_0) \neq 0$.

f is diffeomorphic to the cuspidal cross cap (or the folded umbrella) if and only if $\psi(t_0) = 0, \psi'(t_0) \neq 0$.

6 Geometric structures on spaces

Now we recall the classification of simple Lie algebras over the complex numbers by Dynkin diagrams [4]:

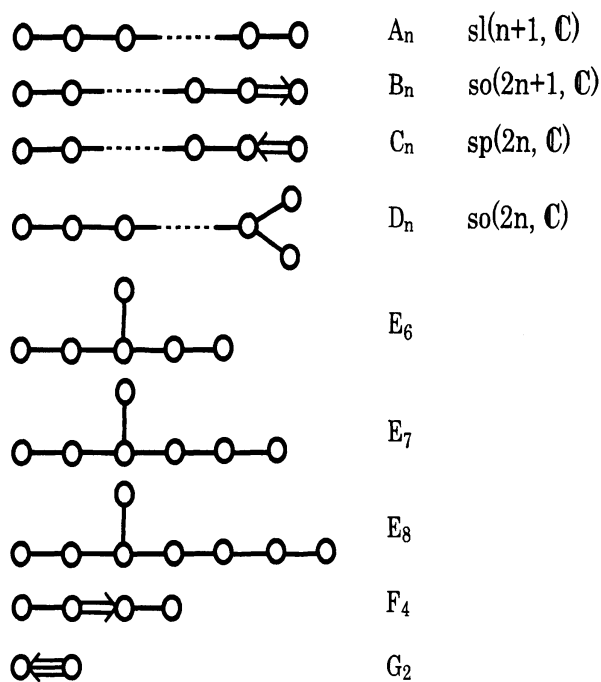

Dynkin diagrams of simple Lie algebras / \mathbb{C}

We also recall the relations on several Dynkin diagrams with few vertices:

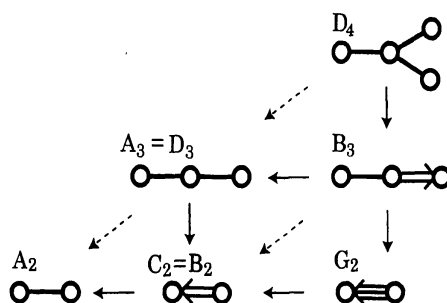

We recall the generic singularities of “tangent maps” of planar fronts in A_2 -geometry (planar projective geometry):

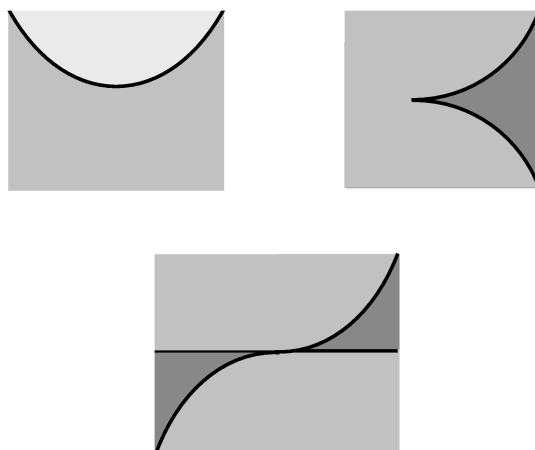

Then the classification of singularities of tangent surfaces looks like an “opening” of A_2 theory. However, we need to construct explicit geometric model and perform detailed calculation to realise the exact list of the classification.

7 Distribution and its integral curves

The notion of “tangent surfaces” is generalised in various ways. For an integral curve in a sub-Riemannian manifold, we regard tangent abnormal geodesics as tangent lines.

Let M be a C^∞ manifold and $\mathcal{D} \subset TM$ a subbundle of the tangent bundle TM . Often \mathcal{D} is called a distribution or a differential system on M .

Definition 7.1 A C^∞ curve $\gamma : \mathbf{R} \rightarrow M$ is called \mathcal{D} -integral if

$$\gamma'(t) \in \mathcal{D} \quad (t \in \mathbf{R}).$$

Moreover $\gamma : \mathbf{R} \rightarrow M$ is called \mathcal{D} -directed if there exists a C^∞ mapping $u : \mathbf{R} \rightarrow \mathcal{D}$ such that the following diagram commutes:

$$\begin{array}{ccc} u : \mathbf{R} & \longrightarrow & \mathcal{D} \\ & \searrow \gamma & \circlearrowleft \swarrow \pi \\ & & M \end{array}$$

and that

$$\begin{cases} u(t) \neq 0, \\ \gamma'(t) \in \langle u(t) \rangle_{\mathbf{R}}, t \in \mathbf{R}. \end{cases}$$

Let (M, \mathcal{D}, g) be a sub-Riemannian manifold. Here $\mathcal{D} \subset TM$ is a (completely non-integrable) distribution, and g is a Riemannian metric on \mathcal{D} . Regarding the problem on length minimising on \mathcal{D} -integral curves $\gamma : [a, b] \rightarrow M$,

$$\ell(\gamma) = \int_a^b \sqrt{g_{\gamma(t)}(\gamma'(t), \gamma'(t))} dt,$$

we have two kinds of geodesics (extremals), **normal geodesics** and **abnormal geodesics**. Note that in Riemannian geometry, where $\mathcal{D} = TM$, all geodesics are normal. Moreover it is known that abnormal geodesics are defined only by the distribution \mathcal{D} .

8 G_2 -Cartan distribution

Let M be a 5-dimensional manifold and $\mathcal{D} \subset TM$ a distribution of rank 2. Then \mathcal{D} is called a **Cartan distribution** if it has growth $(2, 3, 5)$, namely, if $\text{rank}(\mathcal{D}^{(2)}) = 3$ and $\text{rank}(\mathcal{D}^{(3)}) = 5$, where, we define in terms of Lie bracket, $\mathcal{D}^{(2)} = \mathcal{D} + [\mathcal{D}, \mathcal{D}]$ and $\mathcal{D}^{(3)} = \mathcal{D}^2 + [\mathcal{D}, \mathcal{D}^2]$. It is known that, for any point x of M and for any direction $\ell \in \mathcal{D}_x$, there exists an abnormal geodesic, which is unique up to parametrisations, through x with the given direction ℓ .

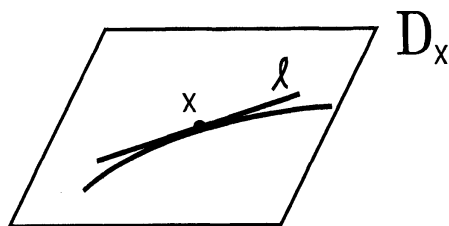

Then, for a given \mathcal{D} -directed curve γ , we define **abnormal tangent surface** of γ , which is ruled by abnormal geodesics through points $\gamma(t)$ with the directions $u(t)$.

On \mathbf{R}^5 with coordinates $(\lambda, \nu, \mu, \tau, \sigma)$, define the distribution $\mathcal{D} \subset T\mathbf{R}^6$ generated by the pair of vector fields

$$\begin{aligned} \eta_1 &= \frac{\partial}{\partial \lambda} + \nu \frac{\partial}{\partial \mu} - (\lambda\nu - \mu) \frac{\partial}{\partial \tau} + \nu^2 \frac{\partial}{\partial \sigma}, \\ \eta_2 &= \frac{\partial}{\partial \nu} - \lambda \frac{\partial}{\partial \mu} + \lambda^2 \frac{\partial}{\partial \tau} - (\lambda\nu + \mu) \frac{\partial}{\partial \sigma}. \end{aligned}$$

Then \mathcal{D} is a Cartan distribution and it has maximal symmetry of dimension 14, maximal among all Cartan distributions, which is of type G_2 , one of simple Lie algebras. The distribution $\mathcal{D} \subset T\mathbf{R}^6$ is also defined by $\{\beta_1 = 0, \beta_2 = 0, \beta_3 = 0\}$, where

$$\begin{aligned} \beta_1 &:= -\nu d\lambda + \lambda d\nu + d\mu = 0, \\ \beta_2 &:= (\lambda\nu - \mu)d\lambda - \lambda^2 d\nu + d\tau = 0, \\ \beta_3 &:= -\nu^2 d\lambda + (\lambda\nu + \mu)d\nu + d\sigma = 0. \end{aligned}$$

Theorem 8.1 ([16], G_2)

For a generic G_2 -Cartan directed curve $\gamma : \mathbf{R} \rightarrow \mathbf{R}^5$, the tangent surfaces at any point $t_0 \in \mathbf{R}$ is classified, up to local diffeomorphisms, into embedded cuspidal edge, open Mond surface, and generic open folded pleat.

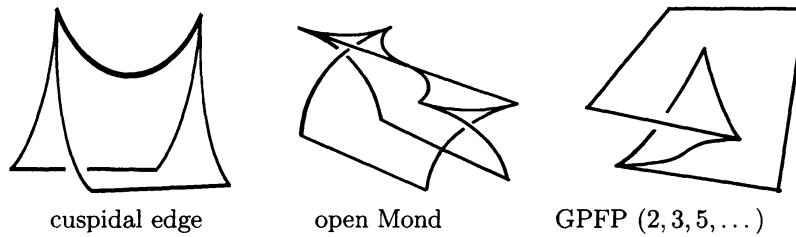

Note that the work is closely related to the rolling ball problem [1][3][2].

9 Null curves in a semi-Riemannian manifold

Let (M, g) be a semi-Riemannian manifold with an indefinite metric g . Denote by $\mathcal{C} \subset TM$ the null cone field associated with the indefinite metric g , i.e. \mathcal{C} is the set of null vectors,

$$\mathcal{C} = \{u \in TM \mid u \in T_x M, g_x(u, u) = 0\}.$$

Definition 9.1 A C^∞ curve $\gamma : \mathbf{R} \rightarrow M$ is called a **null curve** if

$$\gamma'(t) \in \mathcal{C} \quad (t \in \mathbf{R}).$$

Moreover $\gamma : \mathbf{R} \rightarrow M$ is called **null-directed** if there exists a C^∞ mapping $u : \mathbf{R} \rightarrow \mathcal{C}$ such that

$$\begin{array}{ccc} u : & \mathbf{R} & \longrightarrow & \mathcal{C} \\ & \gamma \searrow & \circlearrowleft & \swarrow \pi \\ & & M & \end{array}$$

and that

$$\begin{cases} u(t) \neq 0, \\ \gamma'(t) \in \langle u(t) \rangle_{\mathbf{R}}, t \in \mathbf{R}. \end{cases}$$

Define the “null” tangent surface of a null-directed curve γ as the ruled surface by null geodesics through points $\gamma(t)$ with the directions $u(t)$.

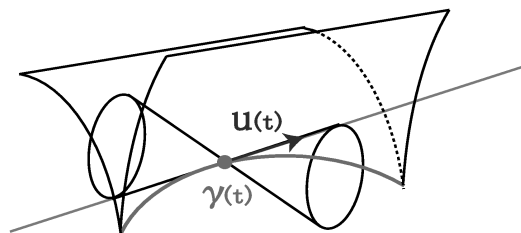

Let $M = \mathbf{R}^{p,q}$ be the \mathbf{R}^{p+q} with the metric of signature (p, q) ,

$$(x|y) = -x_1y_1 - \dots - x_p y_p + x_{p+1}y_{p+1} + \dots + x_{p+q}y_{p+q}.$$

Then we have the generic classification of singularities of tangent surfaces by null geodesics in $\mathbf{R}^{1,2}$:

Theorem 9.2 ($B_2 = C_2$, [6][15])

The singularities of tangent surface $\text{Tan}(\gamma)$ for a generic null directed curve $\gamma : \mathbf{R} \rightarrow \mathbf{R}^{1,2}$ are cuspidal edges, swallowtails and Scherbak surfaces.

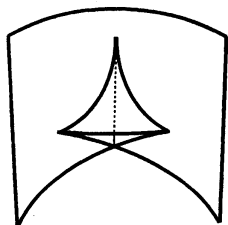

Swallowtail (2, 3, 4)

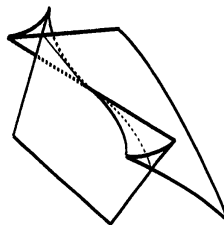

Scherbak surface (1, 3, 5)

Now consider a curve in $\mathbf{R}^{2,2}$. The D_3 -evolute of the curve is defined by the envelope of the 1-parameter of normals along the curve.

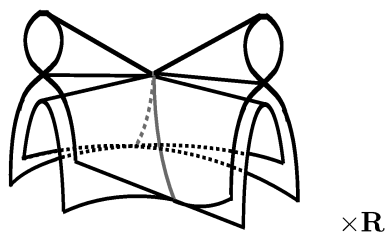

The tangent surface is embedded as (the closure of) a stratum in D^3 -evolute. The Kazaryan’s bi-umbrella appears as a transversal section of the evolute.

Then we have the classification result on singularities of tangent surfaces:

Theorem 9.3 (D_3 , [18]) The singularities of tangent surface $\text{Tan}(\gamma)$ for a generic null directed curve $\gamma : \mathbf{R} \rightarrow \mathbf{R}^{2,2}$ are embedded cuspidal edges and open swallowtails.

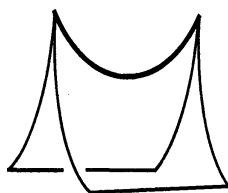

embedded cuspidal edge (1, 2, 3, ...),

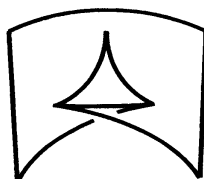

open swallowtail (2, 3, 4, 5)

For generic singularities of tangent surfaces by null geodesics in $\mathbf{R}^{2,3}$, we have:

Theorem 9.4 *Theorem (B_3 , [18]) The singularities of tangent surface $\text{Tan}(\gamma)$ for a generic null directed curve $\gamma : \mathbf{R} \rightarrow \mathbf{R}^{2,3}$ are embedded cuspidal edges, open swallowtails, open Mond surfaces and unfurled folded umbrellas.*

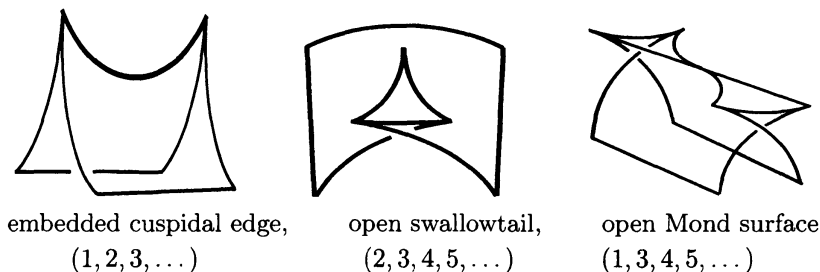

The **unfurled folded umbrella** is the singularities of the tangent surface of a curve of type $(1, 2, 4, 6, 7)$.

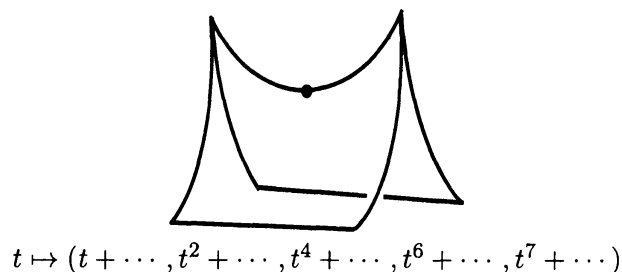

For the generic singularities of tangent surfaces by null geodesics in $\mathbf{R}^{3,3}$, we have:

Theorem 9.5 *(D_4 , [17]) The singularities of tangent surface $\text{Tan}(\gamma)$ for a generic null directed curve $\gamma : \mathbf{R} \rightarrow \mathbf{R}^{3,3}$ (the projection of a generic “Engel integral” curve) are embedded cuspidal edges, open swallowtails and open Mond surfaces.*

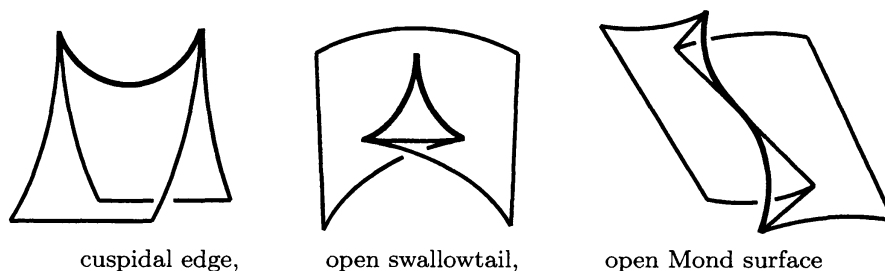

10 Type of a curve and singularity of tangent surface

Several types for curves uniquely determine the local diffeomorphism classes of tangent surfaces.

Singularity of tangent surface	Type of curve
Mond surface	$(1, 3, 4)$
open Mond surface	$(1, 3, 4, 5, \dots)$
unfurled Mond surface	$(1, 3, 4, 6, \dots)$
Scherbak surface	$(1, 3, 5)$
open Scherbak surface	$(1, 3, 5, 7, 8, \dots)$
unfurled folded umbrella	$(1, 2, 4, 6, 7, \dots)$

These characterisations are confirmed in the flat case so far. To confirm these characterisation of singularities in non-flat case is an interesting problem.

References

- [1] A.A. Agrachev, *Rolling balls and octonions*, Proc. Steklov Inst. of Math, **258** (2007), 13–22.
- [2] J. C. Baez, J. Huerta, *G_2 and the rolling ball*, Trans. Amer. Math. Soc. **366** (2014), 5257–5293.
- [3] G. Bor, R. Montgomery, *G_2 and the rolling distributions*, Enseign. Math. **55** (2009), 157–196.
- [4] N. Bourbaki, *Groupes et Algebres de Lie*, Chapitre 4 a 6, Hermann (1968), Springer (2007).
- [5] A. Cayley, Mémoire sur les courbes à double courbure et les surfaces développables, Journal de Mathématique Pure et Appliquées (Liouville), **10** (1845), 245–250 = The Collected Mathematical Papers vol. I, pp. 207–211.
- [6] S. Chino, S. Izumiya, *Lightlike developables in Minkowski 3-space*, Demonstratio Mathematica **43–2** (2010), 387–399.
- [7] J.P. Cleave, *The form of the tangent-developable at points of zero torsion on space curves*, Math. Proc. Cambridge Philos. Soc. **88–3** (1980), 403–407.
- [8] V. Guillemin, S. Sternberg, *Variations on a Theme by Kepler*, Amer. Math. Colloquium Publ. **42**, Amer. Math. Soc. (1990).
- [9] G. Ishikawa, *Determinacy of the envelope of the osculating hyperplanes to a curve*, Bull. London Math. Soc., 25(1993), pp.603–610.
- [10] G. Ishikawa, *Developable of a curve and determinacy relative to osculation-type*, Quart. J. Math. Oxford, **46** (1995) 437–451.
- [11] G. Ishikawa, *Singularities of developable surfaces*, London Math. Soc. Lect. Notes Series, **263** (1999), 403–418.
- [12] G. Ishikawa, *Determinacy, transversality and Lagrange stability*, Banach Center Publications, **50–1** (1999), 123–135.
- [13] G. Ishikawa, *Topological classification of the tangent developables of space curves*, J. London Math. Soc., **62** (2000), 583–598.
- [14] G. Ishikawa, *Singularities of tangent varieties to curves and surfaces*, Journal of Singularities, **6** (2012), 54–83.
- [15] G. Ishikawa, Y. Machida, M. Takahashi, *Asymmetry in singularities of tangent surfaces in contact-cone Legendre-null duality*, Journal of Singularities, **3** (2011), 126–143.
- [16] G. Ishikawa, Y. Machida, M. Takahashi, *Singularities of tangent surfaces in Cartan’s split G_2 -geometry*, Hokkaido University Preprint Series in Mathematics #1020, (2012). To appear in Asian Journal of Mathematics.
- [17] G. Ishikawa, Y. Machida, M. Takahashi, *Geometry of D_4 conformal triality and singularities of tangent surfaces*, Journal of Singularities, **12** (2015), 27–52.
- [18] G. Ishikawa, Y. Machida, M. Takahashi, *D_n -geometry and singularities of tangent surfaces*, Hokkaido University Preprint Series in Mathematics #1058, (2014). To appear in RIMS Kōkyūroku Bessatsu (2015).
- [19] G. Ishikawa, T. Yamashita, *Affine connections and singularities of tangent surfaces to space curves*, arXiv:1501.07341.
- [20] S. Izumiya, T. Nagai, K. Saji, *Great circular surfaces in the three-sphere*, Diff. Geom. and its Appl., **29–3** (2011), 409–425.
- [21] B. Kostant, *The principle of triality and a distinguished unitary representation of $SO(4,4)$* , Differential geometrical methods in theoretical physics (Como, 1987), 65–108, NATO Adv. Sci. Inst. Ser. C Math. Phys. Sci., 250, Kluwer Acad. Publ., Dordrecht, 1988.

- [22] E. Kreyszig, *Differential Geometry*, University of Toronto Press, Toronto (1959).
- [23] S. Lawrence, *Developable surfaces, their history and application*, Nexus Network J., **13–3** (2011), 701–714.
- [24] M. Mikosz, A. Weber, *Triality in $\mathfrak{so}(4,4)$, characteristic classes, D_4 and G_2 singularities*, preprint (December 2013).
<http://www.mimuw.edu.pl/~aweber/publ.html>
- [25] D. Mond, *On the tangent developable of a space curve*, Math. Proc. Cambridge Philos. Soc. **91–3** (1982), 351–355.
- [26] D. Mond, *Singularities of the tangent developable surface of a space curve*, Quart. J. Math. Oxford Ser. (2) **40** (1989), 79–91.
- [27] D. Mond, *On the classification of germs of maps from \mathbf{R}^2 to \mathbf{R}^3* , Proc. London Math. Soc., **50–2** (1985), 333–369.
- [28] R. Montgomery, *A tour of subriemannian geometries, their geodesics and applications*, Mathematical Surveys and Monographs, **91**, Amer. Math. Soc., Providence, RI, (2002).
- [29] O.P. Shcherbak, *Projective dual space curves and Legendre singularities*, Trudy Tbiliss Univ., **232–233** (1982), 280–336.
- [30] O.P. Shcherbak, *Wavefront and reflection groups*, Russian Math. Surveys **43–3** (1988), 149–194.
- [31] J.J. Stoker, *Differential Geometry*, Pure and Applied Math. **20**, Wiley-Interscience, New York 1969.
- [32] E. Study, *Grundlagen und Ziele der analytischen Kinematik*, Sitzungsberichte der Berliner Mathematischen Gesellschaft, **12** (1913), 36–60.

Goo ISHIKAWA,

Department of Mathematics, Hokkaido University, Sapporo 060-0810, Japan.

e-mail : ishikawa@math.sci.hokudai.ac.jp

(石川 剛郎, 北海道大学大学院理学研究院)