

Problems on Low-dimensional Topology, 2014

Edited by T. Ohtsuki¹

This is a list of open problems on low-dimensional topology with expositions of their history, background, significance, or importance. This list was made by editing manuscripts written by contributors of open problems to the problem session of the conference “Intelligence of Low-dimensional Topology” held at Research Institute for Mathematical Sciences, Kyoto University in May 21–23, 2014.

Contents

1	Applications of Laver tables to braids	2
2	Similarity between number theory and knot theory	4
3	Iwasawa invariants of cyclic covers of link exteriors	4
4	Profinite knots	6
5	Invariants of knots derived from the algebraic K -theory	7
6	1-cocycles in the space of knots	8
7	Canonical arc index of cable links	9
8	The state numbers for virtual knots	11
9	Local and global properties of graphs	13
10	Essential tribranched surfaces in 3-manifolds	14
11	Invariants of homology 3-spheres motivated by the Chern-Simons perturbation theory	16

¹Research Institute for Mathematical Sciences, Kyoto University, Sakyo-ku, Kyoto, 606-8502, JAPAN
Email: tomotada@kurims.kyoto-u.ac.jp

1 Applications of Laver tables to braids

(Victoria Lebed)

A *Laver table* A_n is the set $\{1, 2, 3, \dots, 2^n\}$ endowed with the unique binary operation \triangleright_n satisfying the (*left*) *self-distributivity condition*

$$a \triangleright_n (b \triangleright_n c) = (a \triangleright_n b) \triangleright_n (a \triangleright_n c) \tag{1}$$

and the initial condition $a \triangleright_n 1 \equiv a + 1 \pmod{2^n}$. They form an infinite family of finite *shelves* (= sets endowed with a self-distributive operation). The smallest examples are presented in Figure 1; the cell (i, j) of the table for A_n contains $i \triangleright_n j$. In the table for A_1 one recognizes operation “implication” from Logic.

A_0	1									
1	1									
A_1	1	2								
1	2	2								
2	1	2								
A_2	1	2	3	4						
1	2	4	2	4						
2	3	4	3	4						
3	4	4	4	4						
4	1	2	3	4						
A_3	1	2	3	4	5	6	7	8		
1	2	4	6	8	2	4	6	8		
2	3	4	7	8	3	4	7	8		
3	4	8	4	8	4	8	4	8		
4	5	6	7	8	5	6	7	8		
5	6	8	6	8	6	8	6	8		
6	7	8	7	8	7	8	7	8		
7	8	8	8	8	8	8	8	8		
8	1	2	3	4	5	6	7	8		

Figure 1: Multiplication tables for the first four Laver tables

Laver tables were discovered by Richard Laver as a by-product of his analysis of iterations of elementary embeddings in Set Theory [33]. Since then this structure was redefined in elementary terms (as above), and many of its deep properties were given a combinatorial proof. However, as for now, some fundamental facts about Laver tables have been established only under an unprovable large cardinal axiom. One of them states that the inverse limit of the A_n contains a copy of the shelf \mathcal{F}_1 freely generated by a single element.

Shelves have gained recognition among knot theorists due to *coloring* techniques. Namely, a coloring of a positive braid diagram D by a shelf (Q, \triangleright) assigns an element of Q to every arc of D in such a way that a b -colored strand becomes $(a \triangleright b)$ -colored when it over-crosses an a -colored strand. Figure 2 shows that this coloring condition is compatible with the RIII move thanks to (1). Hence the number of Q -colorings of diagrams yields an invariant of underlying positive braids. This invariant extends to arbitrary braids if Q is a *rack* (*i.e.*, for all b , the map $a \mapsto b \triangleright a$ is bijective on Q), and to knots if Q is a *quandle* (= a rack where every element is idempotent: $a \triangleright a = a$). Such *Q-coloring counting invariants* turn out to be extremely powerful and well adapted for actual calculations.

Now, even though the free shelf \mathcal{F}_1 is not a rack, the \mathcal{F}_1 -colorings of arbitrary braid diagrams are still meaningful. In particular, when applied to braid diagrams

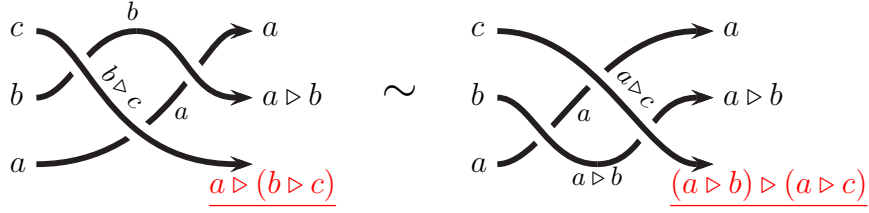

Figure 2: Reidemeister III move \iff self-distributivity

presented in the normal form, they lead to a construction of a well-behaved order on braids [12]. Since conjecturally Laver tables are finite approximations of \mathcal{F}_1 , it is natural to expect that A_n -colorings can also say a lot about arbitrary braids. Moreover, because of the finiteness, they are well adapted for computations. The following question thus seems very promising:

Question 1.1 (P. Dehornoy [13]). *How can one extract topological information from the colorings by Laver tables in the case of arbitrary braids?*

A possible strategy for answering this question involves *rack cohomology*, as developed in [17, 8]. For a shelf (Q, \triangleright) , rack cohomology $H_{\mathbb{R}}^k(Q)$ is defined as the cohomology of the complex $(\text{Hom}(Q^{\times k}, \mathbb{Z}), d_{\mathbb{R}}^k)$, where $d_{\mathbb{R}}^k = \sum_{i=1}^{k+1} (-1)^{i-1} (d_i^k - \tilde{d}_i^k)$, and

$$\begin{aligned} (d_i^k f)(a_1, \dots, a_{k+1}) &= f(a_1, \dots, a_{i-1}, a_i \triangleright a_{i+1}, \dots, a_i \triangleright a_{k+1}), \\ (\tilde{d}_i^k f)(a_1, \dots, a_{k+1}) &= f(a_1, \dots, a_{i-1}, a_{i+1}, \dots, a_{k+1}). \end{aligned}$$

The 2-cocycles from this cohomology theory — that is, maps $\phi : Q \times Q \rightarrow \mathbb{Z}$ satisfying

$$\phi(a \triangleright b, a \triangleright c) + \phi(a, c) = \phi(a, b \triangleright c) + \phi(b, c)$$

— are of particular importance. Evaluate such a 2-cocycle on the colors adjacent to each crossing of a Q -colored positive braid diagram as shown on Figure 3, and sum up the values obtained. Figure 3 proves the multi-set of the results of this summation for all possible Q -colorings to be an invariant of positive braids. These *Q -coloring cocycle invariants* sharpen the Q -coloring counting invariants: the latter are obtained by considering any constant 2-cocycle ϕ . A slight modification of this method involves region coloring and rack 3-cocycles.

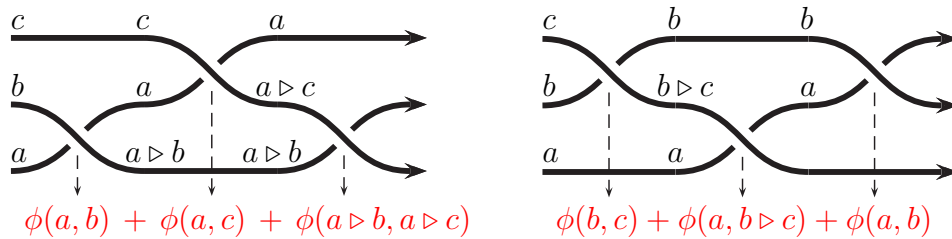

Figure 3: Two-cocycle $\phi \rightsquigarrow$ diagram weights

In [14], we explicitly described rack 2- and 3-cocycles for all the A_n . They form free modules over \mathbb{Z} of rank 2^n and, respectively, $2^{2^n} - 2^n + 1$, giving rich families

of A_n -coloring cocycle invariants. We showed that these cocycles capture important combinatorial properties of the A_n . Question 1.1 can now be narrowed as follows:

Question 1.2 (Dehornoy-Lebed [14]). *How can one extract topological information from the colorings by Laver tables, weighted by rack 2- or 3-cocycles, in the case of arbitrary braids?*

Independently of topological applications, rack cohomology calculations for Laver tables can be instrumental for a better understanding of the structure of the A_n . In [14], we established that $H_{\mathbb{R}}^k(A_n) \simeq \mathbb{Z}$ for all n and for $k \leq 3$.

Conjecture 1.3 (V. Lebed). *For all Laver tables A_n and integers k , the rack k -cocycles for A_n form free modules over \mathbb{Z} of rank $\theta_k(2^n)$, where θ_k is a degree $k - 1$ polynomial with integer coefficients. Moreover, one has $H_{\mathbb{R}}^k(A_n) \simeq \mathbb{Z}$, with (the equivalence class of) the constant cocycle $\phi(a_1, \dots, a_k) = 1$ as generator.*

Preliminary computations confirm this conjecture for $k = 4$. However, calculation methods for general k are still missing. It would also be interesting to find explicit formulas for the polynomials θ_k and to study their properties.

Further, as follows from the work of A. Drápal [15, 55], all finite shelves with a single generator can be regarded as “interpolations” between Laver tables and cyclic shelves C_m (i.e., sets $\{1, 2, 3, \dots, m\}$ with the operation defined by $a \circ_m b \equiv b + 1 \pmod{m}$). Like for Laver tables, first cohomology groups for the C_m turn out to be isomorphic to \mathbb{Z} .

Conjecture 1.4 (V. Lebed). *For all finite mono-generated shelves Q , one has $H_{\mathbb{R}}^k(Q) \simeq \mathbb{Z}$.*

2 Similarity between number theory and knot theory

(Teruhisa Kadokami)

Number Theory and Knot Theory are said ‘similar’ because Galois Theory in Number Theory and Alexander Theory in Knot Theory are similar theoretically [39, 43]. They may be unified from a group theoretical view point; see Figure 4.

Problem 2.1. *Describe clearly a unified notion of Number Theory and Knot Theory.*

3 Iwasawa invariants of cyclic covers of link exteriors

(Yasushi Mizusawa)

Let L be a link in a rational homology 3-sphere M , and let X be the exterior of L with the fundamental group $G_L = \pi_1(X)$. A surjective homomorphism $\sigma : G_L \rightarrow \mathbb{Z}$ corresponds to an infinite cyclic cover X_σ over X . Let X_{σ, p^n} be the subcover of degree p^n , for a fixed prime number p . Then we obtain a tower $\{M_{\sigma, p^n}\}_n$ of cyclic branched covers M_{σ, p^n} of M as the Fox completions of X_{σ, p^n} . Based on the analogy between

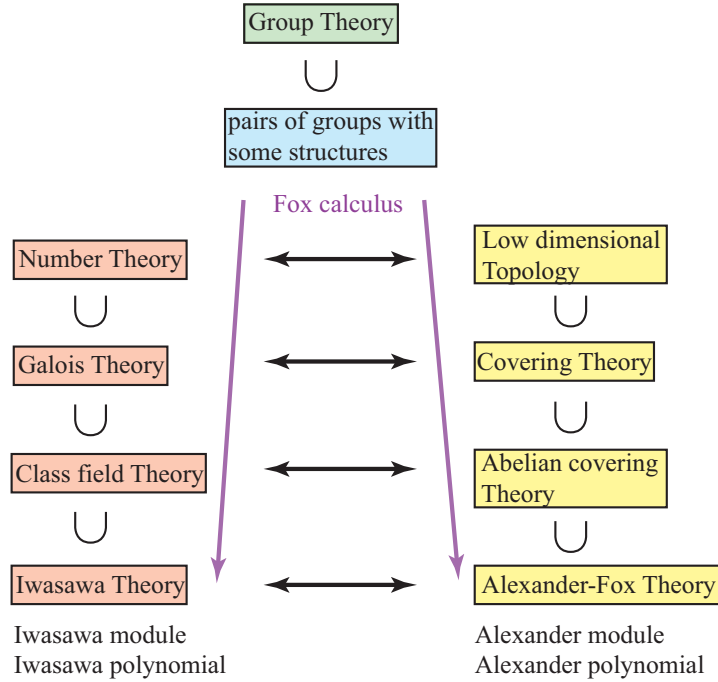

Figure 4: Similarity between Number Theory and Knot Theory

knot theory and number theory, Morishita *et. al.* ([25, 28, 42]) gave an analogue of Iwasawa's class number formula (*cf.* [61] etc.): Assume that $H_1(M_{\sigma,p^n}; \mathbb{Z})$ is finite for all $n \geq 0$. Then there are non-negative integers $\lambda_{L,\sigma}$, $\mu_{L,\sigma}$ and an integer $\nu_{L,\sigma}$ (possibly negative) such that

$$v_p(\#H_1(M_{\sigma,p^n}; \mathbb{Z})) = \lambda_{L,\sigma} n + \mu_{L,\sigma} p^n + \nu_{L,\sigma}$$

for all sufficiently large n , where v_p denotes the p -adic valuation normalized as $v_p(p) = 1$. These invariants $\lambda_{L,\sigma}$, $\mu_{L,\sigma}$, $\nu_{L,\sigma}$ are called Iwasawa invariants.

Professor Masato Kurihara gave us the following problem.

Problem 3.1. *Refine the formula removing the finiteness of $H_1(M_{\sigma,p^n}; \mathbb{Z})$, i.e., give a p -adic growth formula for the torsion part of $H_1(M_{\sigma,p^n}; \mathbb{Z})$.*

The following problem also seems to be considerable. A partial result is obtained in [29].

Problem 3.2 (T. Kadokami, Y. Mizusawa). *Determine the possible values of $\lambda_{L,\sigma}$, $\mu_{L,\sigma}$ and $\nu_{L,\sigma}$.*

We often consider a non-archimedean prime (a prime ideal of the integer ring of a number field) as an analogue of 1-component link (a knot). However, in the analogies between Alexander-Fox theory and Iwasawa theory, the set of all prime ideals lying over a fixed prime number p in a *totally real* number field looks like 1-component link. It seems that the following problem is considerable to understand the archimedean primes more deeply in arithmetic topology.

Problem 3.3 (T. Kadokami, Y. Mizusawa). *What is “the number of components” of a prime ?*

If L is an r -component link in S^3 , the link module B_L and the Alexander module A_L are modules over $\Lambda = \mathbb{Z}[t_1^{\pm 1}, \dots, t_r^{\pm 1}]$. Then there is a natural injective Λ -homomorphism $\theta : B_L \hookrightarrow A_L$. Let M_L be the Λ -submodule of A_L generated by *meridional elements* (cf. [24]). Motivated by Greenberg’s conjecture (cf. [21]) in Iwasawa theory, the following problem is proposed (with some examples) in [29], which is *not* a strict analogue of the conjecture.

Problem 3.4 (T. Kadokami, Y. Mizusawa). *When is $Y_L := B_L/\theta^{-1}(M_L)$ a pseudonull Λ -module ?*

If we have a homomorphism $\rho : G_L \rightarrow GL_d(\mathbb{Z}_p)$ with *large* image, we obtain a p -adic Lie tower over X . (The tower $\{X_{\sigma, p^n}\}_n$ is a p -adic Lie tower for $d = 1$.) In [3, 7] etc., the growth of Betti numbers in a p -adic Lie tower is studied. The invariant $\lambda_{L, \sigma}$ can be regarded as a kind of Betti numbers. Motivated by analogous studies ([50] etc.) in noncommutative Iwasawa theory, we have the following problem.

Problem 3.5 (T. Kadokami, Y. Mizusawa). *Give Iwasawa type formulas for p -adic Lie towers of branched covers over L , with many examples.*

4 Profinite knots

(Hidekazu Furusho)

Let \mathcal{K} be the set of isotopy classes of oriented (topological) knots, which forms a commutative monoid by the connected sum. Let $\widehat{\mathcal{K}}$ be the monoid of profinite knots constructed in [18]. The set $\widehat{\mathcal{K}}$ forms a topological commutative monoid by the connected sum and there is a natural monoid homomorphism

$$h : \mathcal{K} \longrightarrow \widehat{\mathcal{K}}$$

whose image is dense in $\widehat{\mathcal{K}}$, as is shown in [18].

Problem 4.1 (H. Furusho). *Is the map h injective?*

If it is non-injective, then the Kontsevich knot invariant fails to be perfect.

As for Artin braid group B_n ($n \geq 2$), it is known that B_n is residually finite, namely, the natural map

$$B_n \longrightarrow \widehat{B}_n$$

is injective.

Problem 4.2 (H. Furusho). *Is there any Alexander-Markov-like theorem for profinite links?*

One can find several proofs of Alexander-Markov’s theorem for topological links ([4, 58, 60, 64] etc). However they look heavily based on a certain finiteness property, which we may not expect the validity for profinite links.

Let $\text{Frac } \widehat{\mathcal{K}}$ be the fractional group of $\widehat{\mathcal{K}}$, which forms a topological commutative group. The action of the absolute Galois group $G_{\mathbb{Q}} := \text{Gal}(\overline{\mathbb{Q}}/\mathbb{Q})$ of rationals \mathbb{Q} on $\text{Frac } \widehat{\mathcal{K}}$ was constructed in [18].

Problem 4.3 (H. Furusho). *Is the $G_{\mathbb{Q}}$ -action on $\text{Frac } \widehat{\mathcal{K}}$ faithful?*

As for the braid groups, the $G_{\mathbb{Q}}$ -action on \widehat{B}_n is known to be faithful for $n \geq 3$ by Belyi's theorem [2].

Problem 4.4 (H. Furusho). *Does there exist any (co)homology theory H_{\star} (or any fundamental group theory π_1^{\star}) and any (pro-)variety X defined over \mathbb{Q} such that $H_{\star}(X_{\overline{\mathbb{Q}}})$ (resp. $\pi_1^{\star}(X_{\overline{\mathbb{Q}}})$) carries a natural $G_{\mathbb{Q}}$ -action and $\text{Frac } \widehat{\mathcal{K}}$ is identified with $H_{\star}(X_{\overline{\mathbb{Q}}})$ (resp. $\pi_1^{\star}(X_{\overline{\mathbb{Q}}})$) so that our $G_{\mathbb{Q}}$ -action on $\text{Frac } \widehat{\mathcal{K}}$ can be derived from the $G_{\mathbb{Q}}$ -action there?*

5 Invariants of knots derived from the algebraic K -theory

(Takefumi Nosaka)

We start preliminarily recalling K -theoretic results in knot theory. In general, the concept of K -groups often plays a role to uniformly understand several mathematical phenomena. As examples in 3-dimensional knot theory, fixing a commutative field F , values in K_1 -, K_3 -groups obtained from SL_2 -representations of link groups $\pi_1(S^3 \setminus L) \rightarrow SL_2(F)$ are much studied so far. However, as far as I have looked over, I had found no second K -value with respect to such representations f ; so, in [49], I proposed such an invariant valued in “Milnor-Witt K_2 -group $K_2^{MW}(F)$ ” in a natural way, where the preferred longitude is a key in construction. Without the details, the K -invariants are roughly summarized as follows:

K -group	K_1 (Whitehead)	K_2 (Milnor)	K_3 (Quillen)
Link invariant	Twisted Alex. poly.	Longitude [49]	Chern-Simons inv. (see, e.g., [65])

However, the work on the K_2 -value was two years ago; so there are many something mysterious.

Problem 5.1 (T. Nosaka). *Give some applications of the K_2 -value to knot theory or to number theory.*

Problem 5.2 (T. Nosaka). *Describe an arithmetic meaning of the K_2 -values. For example, how about the hyperbolic holonomy of the figure-eight knot 4_1 ?*

Problem 5.3 (T. Nosaka). *If F is a global field, give an example of some representation $\pi_1(S^3 \setminus L) \rightarrow SL_2(F)$ which takes non-trivial global information in $K_2^{MW}(F)$. Actually, in the paper [49], I dealt with some parts of $K_2^{MW}(F)$ only arising from local fields.*

Problem 5.4 (T. Nosaka). *If a hyperbolic holonomy $\pi_1(S^3 \setminus K) \rightarrow SL_2(F)$ is closed under some quadratic field F , the relation between the hyperbolicity (e.g., volume)*

and arithmetic properties (e.g., a special value of the zeta function ξ_F) is well studied (see a comprehensive book [37]). Discover an arithmetic relation of the K_2 -value.

Furthermore, compare the K_2 -value with Birsh-Tate conjecture that states the equality

$$\zeta_F(-1) \stackrel{?}{=} (-1)^{r_1} |K_2(\mathcal{O}_F)| / |K_3(\mathcal{O}_F)|,$$

where F is a totally real field, and \mathcal{O}_F is the ring of integers in F .

To solve them, the following two interpretations of $K_2^{MW}(F)$ in number theory would be useful: First, from \mathbb{A}^1 -homotopy theory, two isomorphisms

$$K_2^{MW}(F) \cong \pi_1^{\mathbb{A}^1}(SL_2(F)) \cong \pi_1^{\mathbb{A}^1}(\mathbb{A}^2 \setminus 0)$$

hold via “ \mathbb{A}^1 -Galois correspondence” or “(stable) sphere \mathbb{A}^1 -spectrum”; see [41] for details. Next, following Merkujev-Suslin theorem, we can analyse the m -torsion part of $K_2^{MW}(F)$ from $H_{\text{ét}}^2(\text{Spec}(F); \mu_m^{\otimes 2})$ or the Brauer m -group ${}_m\text{Br}(F)$ via “the Galois symbol”, if F contains a primitive m -th root of unity; see, e.g., [63].

Incidentally, it is not invaluable to consider some problems parallel to knotted surfaces:

Problem 5.5 (T. Nosaka). *With respect to a knotted surface $K \subset S^4$ with a representation $\pi_1(S^4 \setminus K) \rightarrow SL_2(F)$, construct invariants which are valued in K_2 , K_3 or K_4 -group of F .*

6 1-cocycles in the space of knots

(Arnaud Mortier)

Following V.A.Vassiliev [59] we consider the space \mathcal{K} of smooth immersions $\mathbb{R} \rightarrow \mathbb{R}^3$ that coincide with the map $t \mapsto (0, 0, t)$ outside of the segment $[-1, 1]$. The subset of singular immersions (that are *not* embeddings) is denoted by Σ and called the *discriminant* of \mathcal{K} . The complement $\mathcal{K} \setminus \Sigma$ is the set of (*smooth*) *long knots*.

When speaking of the cohomology of the space of knots, we mean the cohomology of $\mathcal{K} \setminus \Sigma$. At the zeroth level, the cohomology group $H^0(\mathcal{K} \setminus \Sigma; \mathbb{Q})$ is the set of \mathbb{Q} -valued knot invariants. Our main object of interest here is the first cohomology group $H^1(\mathcal{K} \setminus \Sigma; \mathbb{Q})$, shortly denoted by H^1 . In [59], Vassiliev introduced particular cohomology classes of the space of knots, well-known in degree 0 as *finite-type knot invariants*. Vassiliev (or finite-type) 1-cohomology classes form a subgroup $H_{f.t.}^1$ of H^1 .

Question 6.1 (A. Mortier). *Is there an axiomatic description of $H_{f.t.}^1$ similar to the well-known axiomatization of Vassiliev invariants by J.Birman and X.-S.Lin [5]?*

One interest of considering 1-cocycles is that their evaluation on specific cycles leads to knot invariants. For this, the cycles need to be defined independently of the knot. Examples of such cycles are:

- $rot(K)$, the positive rotation of a long knot K around its axis;

- $drag(K)$, the dragging of the second component of the connected sum $K\sharp K$ along the first (as in the proof of the equality $K\sharp L = L\sharp K$);
- $Hat(K)$, the Hatcher cycle, which consists of dragging a “ball at infinity” all along a fixed representation of a knot in S^3 .

Problem 6.2 (A. Mortier). *Find other examples of cycles in the space $\mathcal{K} \setminus \Sigma$, that are defined independently of the knot.*

Question 6.3 (A. Mortier). *The evaluation on the above cycles defines maps rot^* , $drag^*$ and Hat^* from H^1 to the set of knot invariants H^0 . Is it true that under these maps, the image of a finite-type 1-cocycle is a finite-type invariant?*

Since M.Polyak and O.Viro [51], followed by M.Goussarov [19], it is known that finite-type knot invariants can be represented by means of linear combinations of Gauss diagrams. This idea was extended in [44] to produce combinatorial presentations of 1-cocycles, as follows.

We fix a linear projection $\mathbb{R}^3 \rightarrow \mathbb{R}^2$ that is generic with respect to the axis of long knots. Then, given a cycle of knot diagrams, we make a list of the Reidemeister moves involved, depicted as Gauss diagrams with singularities, and count their subdiagrams with prescribed weights that define the 1-cocycle.

Question 6.4 (A. Mortier). *Is it true that any 1-cocycle with a combinatorial description as above represents a finite-type cohomology class?*

For finite-type invariants there is a link between Polyak-Viro’s combinatorial formulas and integral formulas, described in [52]. Integral formulas for 1-cocycles have been found by K.Sakai in [53].

Question 6.5 (A. Mortier). *Is there a link between the integral formulas from [53] and the combinatorial formulas from [44]?*

7 Canonical arc index of cable links

(Hwa Jeong Lee and Hideo Takioka)

An *open-book decomposition* of \mathbb{R}^3 is a decomposition which has open half planes as pages and the standard z -axis as the binding axis. An *arc presentation* of a link L is an embedding of L in finitely many pages of an open-book decomposition so that each of these pages meets L in a single simple arc. It is known that every link has an arc presentation [10]. The *arc index*, denoted by $\alpha(L)$, of a link L is the minimum number of pages needed for L to be presented as an arc presentation. It is known that the arc index equals the crossing number plus two for non-split alternating links [1, 45, 56]. For a non-alternating prime link L , we have the following inequality [27, 45]:

$$\text{spread}_a(F_L(a, z)) + 2 \leq \alpha(L) \leq c(L),$$

where $F_L(a, z)$ is the Kauffman polynomial of L and $c(L)$ is the crossing number of L . It is important to determine the arc indices of non-alternating links. Since the arc indices of torus knots are determined in [16], we focus on cable links.

A *grid diagram* of a link is a link diagram which consists of vertical and horizontal line segments with the properties that at each crossing the vertical line segment crosses over the horizontal line segment and no two horizontal line segments are collinear and no two vertical line segments are collinear. A grid diagram with n vertical line segments is easily converted to an arc presentation on n pages, and vice versa [10]. Therefore, the arc index of L can be defined as the minimum number of vertical line segments among all grid diagrams of L .

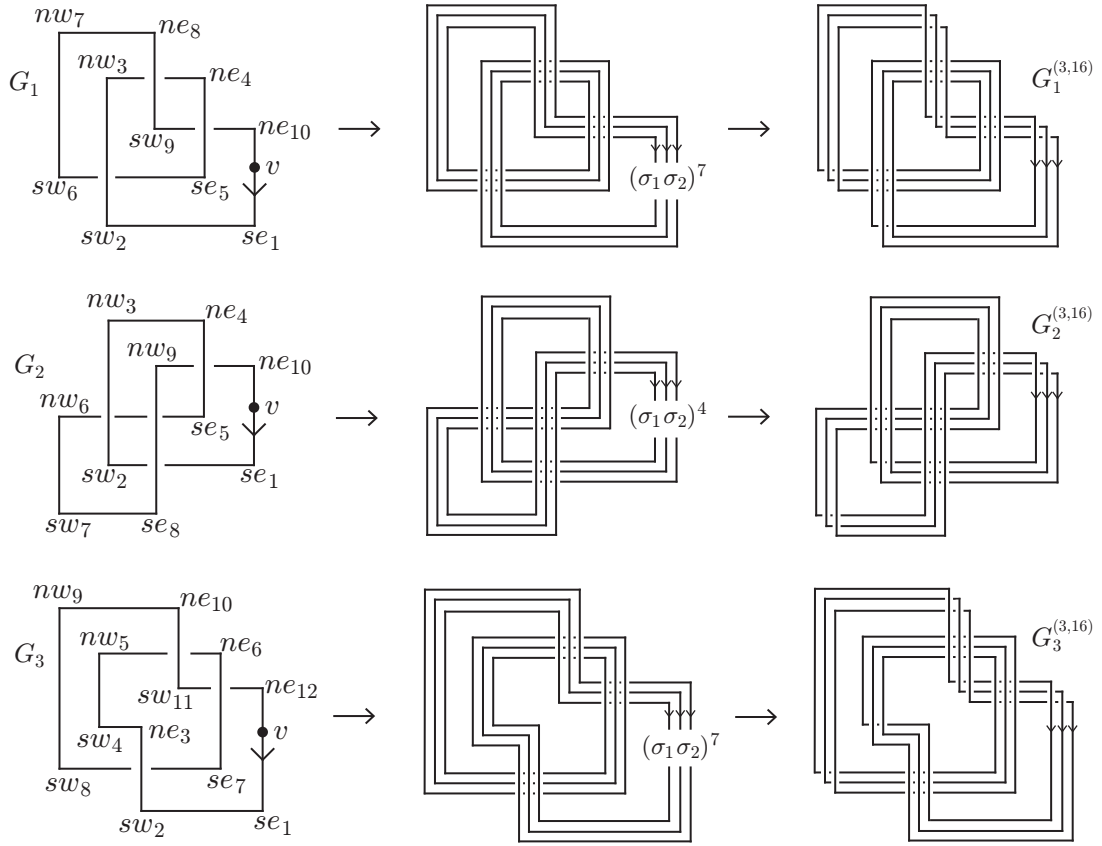

Figure 5: $\alpha(G_1^{(3,16)}) = \alpha(G_2^{(3,16)}) = 15$, $\alpha(G_3^{(3,16)}) = 18$ for grid diagrams G_1, G_2, G_3 of the right handed trefoil

Let G be a grid diagram of a knot K and p, q integers with $p > 0$. In [35], we constructed an algorithm called the *canonical (p, q) -cabling algorithm* of G in order to obtain a sharper upper bound of the arc index of the (p, q) -cable link $K^{(p,q)}$ of K . Briefly, the procedure is given in Figure 5. We call the resulting diagram the *canonical grid diagram* of $K^{(p,q)}$ obtained from G and denote it by $G^{(p,q)}$. Let $\alpha(G^{(p,q)})$ denote the number of vertical line segments of $G^{(p,q)}$. The *canonical arc*

index of $K^{(p,q)}$, denoted by $\alpha_c(K^{(p,q)})$, is defined as follows:

$$\alpha_c(K^{(p,q)}) = \min \{ \alpha(G^{(p,q)}) \mid G \text{ is a grid diagram of } K \}.$$

From the definition of the arc index and the canonical arc index, we have the following inequality:

$$\alpha(K^{(p,q)}) \leq \alpha_c(K^{(p,q)}).$$

Then we have a natural question:

Question 7.1 (H. J. Lee, H. Takioka). $\alpha(K^{(p,q)}) = \alpha_c(K^{(p,q)})$?

It is shown in [35] that the answer of Question 7.1 is “yes” for infinite families of $(2, q)$ -cable links of all prime knots with up to 8 crossings. Moreover, we see that a minimal grid diagram of K leads to the equality above in this special case. The most interesting view is whether any minimal grid diagram of K gives the exact value of arc indices of cable links of K . So, we have natural questions:

Question 7.2 (H. J. Lee, H. Takioka). For two minimal grid diagrams G, G' of a knot K , we have

$$\alpha(G^{(p,q)}) = \alpha(G'^{(p,q)})?$$

Question 7.3 (H. J. Lee, H. Takioka). If G is a minimal grid diagram of a knot K , then we have

$$\alpha_c(K^{(p,q)}) = \alpha(G^{(p,q)})?$$

8 The state numbers for virtual knots

(T. Nakamura, Y. Nakanishi, S. Satoh, Y. Tomiyama)

A *virtual knot diagram* D is a knot diagram in \mathbb{R}^2 with ordinary crossings, which are called *real crossings* $\left(\begin{array}{c} \nearrow \searrow \\ \nwarrow \nearrow \end{array} \right), \left(\begin{array}{c} \nwarrow \nearrow \\ \nearrow \searrow \end{array} \right)$, and *virtual crossings* $\left(\begin{array}{c} \nearrow \searrow \\ \circ \otimes \nwarrow \nearrow \end{array} \right)$. A *virtual knot* K is an equivalence class of virtual knot diagrams under “generalized Reidemeister moves” (cf. [30]).

Let D be a virtual knot diagram. A *state* S of D is a union of circles possibly with virtual crossings obtained from D by splicing all real crossings. A state S is said to be an n -state if S consists of n circles. We denote by $s_n(D)$ the number of n -states of D . The n -state number for a virtual knot K , denoted by $s_n(K)$, is the minimal number of $s_n(D)$ for all possible virtual knot diagrams D for K (cf. [47]).

In [47], the following upper and lower bounds of $s_n(D)$ ($n = 1, 2, 3$) are given: For any virtual knot diagram D with r real crossings, it holds that $1 \leq s_1(D) \leq \frac{2^{r+1} - (-1)^{r+1}}{3}$, $0 \leq s_2(D) \leq 2^{r-1}$, and $0 \leq s_3(D) \leq 3 \cdot 2^{r-3}$. Moreover, it is showed that $r \leq s_2(D)$ if $r \geq 3$. Virtual knot diagrams realizing the lower bound of each $s_n(D)$ ($n = 1, 2, 3$) are characterized in [47] and [48].

Problem 8.1 (T. Nakamura, Y. Nakanishi, S. Satoh, Y. Tomiyama). Characterize the virtual knot diagrams realizing the upper bound of each $s_n(D)$ ($n = 1, 2, 3$).

Namely, characterize the virtual knot diagrams D with r real crossings satisfying each of

$$s_1(D) = \frac{2^{r+1} - (-1)^{r+1}}{3}, \quad s_2(D) = 2^{r-1}, \quad \text{and} \quad s_3(D) = 3 \cdot 2^{r-3}.$$

Examples of such virtual knot diagrams are given in [47] in terms of their Gauss diagrams.

Let D be a virtual knot diagram. We regard D as the image of an immersion of a circle S^1 into \mathbb{R}^2 with crossing information at each double point. A *Gauss diagram* of D is an oriented circle regarded as the preimage of the immersed circle with chords, each of which connects the preimages of each double point corresponding to a real crossing. A chord is oriented from the preimage of the over-crossing-point to that of the under-crossing-point in the circle, and labeled by the sign of the corresponding real crossing. Two chords of a Gauss diagram G of D is *linked* if their end-points appear along the circle on G alternately. A chord is *free* if it is not linked with any other chords.

Let F_r and F'_r be the Gauss diagrams with r chords as in Figure 6 (1) and (2), respectively. Then we see that F_r produces a virtual knot diagram D satisfying $s_1(D) = \frac{2^{r+1} - (-1)^{r+1}}{3}$, F'_r and F_{r-1} with one free chord produce virtual knot diagrams D satisfying $s_2(D) = 2^{r-1}$. Moreover, F'_{r-2} with two free chords and F_{r-3} with three free chords produce virtual knot diagrams D satisfying $s_3(D) = 3 \cdot 2^{r-3}$.

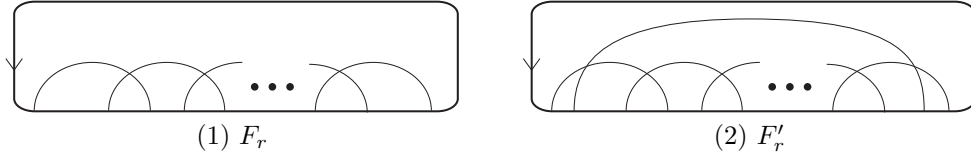

Figure 6

It is known that $s_1(K) \geq |V_K(-1)| = \det K$ for a classical knot K , where $V_K(t)$ is the Jones polynomial for K and $\det K$ is the determinant of K . As a generalization of this fact, lower bounds of $s_1(K)$ for a virtual knot K are given in terms of the Jones polynomial and the Miyazawa polynomial (cf. [26, 40]) in [47].

Problem 8.2 (T. Nakamura, Y. Nakanishi, S. Satoh, Y. Tomiyama). *Find a lower bound for $s_n(K)$ ($n \geq 2$) by algebraic invariants, such as the Jones polynomial, the Miyazawa polynomial and so on.*

J. Green [20] made a table of virtual knots with four real crossings or less. We propose a fundamental problem.

Problem 8.3 (T. Nakamura, Y. Nakanishi, S. Satoh, Y. Tomiyama). *Determine $s_n(K)$ ($n \geq 1$) for the virtual knots in Green's table.*

Y. Tomiyama [57] determined $s_1(K)$ of several virtual knots in the table. In [47], $s_1(K)$ and $s_2(K)$ of the virtual knots with three real crossings or less are determined.

9 Local and global properties of graphs

(Takahiro Matsushita)

A graph is a pair $G = (V(G), E(G))$ where $V(G)$ is a set and $E(G) \subset V \times V$ such that $(x, y) \in E(G)$ implies $(y, x) \in E(G)$. A graph homomorphism from G to H is a map $f : V(G) \rightarrow V(H)$ such that $(f \times f)(E(G)) \subset E(H)$. The existence problem of graph homomorphisms between two graphs is a classical problem of graph theory, and this is closely related to the existence problem of \mathbb{Z}_2 -equivariant maps between given two \mathbb{Z}_2 -spaces. For backgrounds of these topics, see [31].

In [38], r -fundamental groups $\pi_1^r(G)$ and r -covering maps are defined, which can be applied to the existence problem of graph homomorphisms. There is a close relation between r -fundamental groups and r -covering maps as is the case of the covering space theory in topology.

To state the problems suggested here, we give the definition of r -covering maps. For $v \in V(G)$, we write $N(v)$ for $\{w \in V(G) \mid (v, w) \in E(G)\}$, and $N_s(v)$ for $s \geq 1$ is defined by $N_1(v) = N(v)$, $N_{s+1}(v) = \bigcup_{w \in N_s(v)} N(w)$. A graph homomorphism $p : G \rightarrow H$ is called an r -covering map ($r \geq 1$) if for any $v \in V(G)$ and i with $1 \leq i \leq r$, $p|_{N_i(v)} : N_i(v) \rightarrow N_i(p(v))$ is bijective.

Let us observe some phenomena. Let n be a positive integer, and G a connected graph such that $\#N(v) = n$ for any $v \in V(G)$. Consider the following conditions.

- (a) $\#(N(v) \cap N(w)) > n/2$ for any $v, w \in V(G)$ with $w \in N_2(v)$.
- (b) $\#(N(v) \cap N(w)) = 1$ for any $v, w \in V(G)$ with $v \neq w$ and $w \in N_2(v)$.

If G satisfies (a), then the diameter of G is smaller than 4 (and hence, such a G is finite). If G satisfies (b), then $\pi_1^2(G)_{\text{ev}}$ must be free.

From the above phenomena, we can observe that there might be close relations between the “local” and the “global” properties of graphs. Before suggesting questions, let us make the meaning of the “local” property of graphs clear. For a positive integer r , let us call the property (P) of graphs is r -local if for a surjective r -covering map $p : G \rightarrow H$, G satisfies (P) if and only if H satisfies (P). The above properties (a) and (b) are 2-local properties in this definition.

Question 9.1 (T. Matsushita).

- (1) Find r -local properties such that a connected graph satisfying such a property is finite.
- (2) Find r -local properties such that if a connected graph G satisfies such a property, then $\pi_1^r(G)$ is hyperbolic.

As one example of the above question (1), I suggest the following.

Question 9.2 (T. Matsushita). *Is a connected graph G satisfying both the following 2-local property finite?*

- $\sup\{\#N(v) \mid v \in V(G)\} < \infty$.

- For vertices $v, w \in V(G)$ such that $v \neq w$, we have $N(v) \neq N(w)$ and $\#(N(v) \cap N(w)) \neq 1$.

These questions are related to the existence problem of graph homomorphisms. Indeed, if a 2-local property (P) implies the finiteness for connected graphs, then the universal 2-covering of the graph also satisfies (P), and hence is finite. This implies that if a connected graph G satisfies (P), then $\pi_1^2(G)$ is finite, and we have that the chromatic number of G is not equal to 3 by the result of [38].

10 Essential tribranched surfaces in 3-manifolds

(Takashi Hara)

Throughout this section let M be a 3-manifold which is compact, connected, irreducible and orientable. A closed subspace Σ of M is called a *tribranched surface* if the following conditions are fulfilled:

(TBS0) the pair (M, Σ) is locally homeomorphic to $(\mathbb{C} \times [0, \infty), Y \times [0, \infty))$, where Y is a closed subspace of \mathbb{C} defined as

$$Y = \left\{ re^{\sqrt{-1}\theta} \mid r \in [0, \infty), \theta = 0, \pm \frac{2}{3}\pi \right\};$$

(TBS1) the intersection of Σ and a sufficiently small tubular neighbourhood of $C(\Sigma)$ in M is homeomorphic to $Y \times C(\Sigma)$;

(TBS2) each connected component of $S(\Sigma)$ is orientable.

Here we denote by $C(\Sigma)$ the closed subset of Σ (called the *branch set* of Σ) which corresponds to the subset $\{0\} \times [0, \infty)$ of $\mathbb{C} \times [0, \infty)$ under the identification in (TBS0), by $S(\Sigma)$ the complement of a sufficiently small tubular neighbourhood of $C(\Sigma)$ in Σ , and by $M(\Sigma)$ the complement of a sufficiently small tubular neighbourhood of Σ in M .

Now let us focus on a certain class of tribranched surfaces contained in 3-manifolds. A tribranched surface Σ in M is said to be *essential* if it has following properties:

(ETBS1) for each connected component N of $M(\Sigma)$, the natural functorial homomorphism $\pi_1(N) \rightarrow \pi_1(M)$ is not surjective;

(ETBS2) for connected components C , S and N of $C(\Sigma)$, $S(\Sigma)$ and $M(\Sigma)$ respectively, the natural functorial homomorphisms $\pi_1(C) \rightarrow \pi_1(S)$ and $\pi_1(S) \rightarrow \pi_1(N)$ are injective (if they exist);

(ETBS3) there does not exist a connected component of Σ which is contained in a ball in M or a collar of ∂M .

The notion of essential tribranched surfaces is a natural generalisation of that of *essential surfaces* in a usual sense; indeed an essential surface is regarded as an essential tribranched surface with the *empty* branch set. Based upon geometry of character varieties of higher-dimensional representations and the theory of Bruhat-Tits

buildings, we may systematically construct essential tribranched surfaces contained in a 3-manifold M , which may be regarded as a natural extension of the method of Marc Culler and Peter B. Shalen in [11] (the main theorem of [23]; refer also to [22]). The first problem is whether or not our method provides a more sophisticated way even in the construction of essential surfaces (without branch sets). Namely,

Question 10.1 (T. Hara, T. Kitayama). *It is known that there exist essential surfaces which one could not obtain utilising the method of Culler and Shalen. Can one construct such essential surfaces by applying the construction in [23]?*

One great merit of our method is that we may apply this construction even to 3-manifolds whose associated SL_2 -character varieties are of dimension zero; in particular, we may apply it to (a certain class of) *non-Haken manifolds*! It is thus in the nature of things that essential tribranched surfaces are expected to contain fruitful information concerning topological properties of non-Haken manifolds.

Problem 10.2 (T. Hara, T. Kitayama). *Extract topological information of (non-Haken) 3-manifolds from the information of essential tribranched surfaces contained in them.*

Let us deal with a more concrete question concerning Problem 10.2. In the low-dimensional topology, it is widely known that the procedures for cutting along essential surfaces endow a Haken manifold with a structure called the *Haken hierarchy*. This simple observation leads us to the following naive question.

Question 10.3 (T. Hara, T. Kitayama). *Do the procedures for cutting along essential tribranched surfaces² endow a manifold (containing essential tribranched surfaces) with a certain structure like the Haken hierarchy?*

The notion of essential tribranched surface itself is, however, quite new and rather mysterious at the present, and therefore we might have to study topological properties of essential tribranched surfaces more deeply before trying Problem 10.2 or Question 10.3.

Next we point out that essential tribranched surfaces are deeply related to the theory of *complexes of groups*, as essential surfaces (in a usual sense) are to Bass and Serre's theory of *graphs of groups*. Indeed we may associate a 2-complex of groups $G(\mathcal{Y}_\Sigma)$ in a canonical manner to an essential tribranched surface Σ contained in M (see [23] for details). Contrary to graphs of groups, a 2-complex of groups does not always come from a group action on a (contractible) 2-complex (see [6, Chapter III.C] and [9]). To guarantee that $G(\mathcal{Y}_\Sigma)$ comes from an action of $\pi_1(M)$ on a contractible 2-complex, we should impose the following additional condition on Σ :

(ETBS4) for each connected component N of $M(\Sigma)$, the natural functorial homomorphism $\pi_1(N) \rightarrow \pi_1(M)$ is injective.

²Here we remark that, after cutting along an essential tribranched surface, the resulted manifold is equipped with a structure as a sutured manifold.

We call an essential tribranched surface Σ satisfying the additional condition (ETBS4) a *strongly essential* tribranched surface. The additional condition (ETBS4) is a rather algebraic (and ad hoc) condition, and thus we are interested in whether or not there exists a *topological* criterion which distinguishes the notion of strong essentiality from that of essentiality.

Question 10.4 (T. Hara, T. Kitayama). *Does there exist a topological (or geometrical) characterisation of strongly essential tribranched surfaces?*

We remark that there is a geometric sufficient condition for a 2-complex of groups to come from a group action on a (contractible) 2-complex, which is called the *non-positive curvature condition* (for details see [6, 9]). The “answer” to Question 10.4 might be related to such a kind of conditions.

We would like to end this section with a practical problem. Note that we may not apply the method of [23] if the associated character variety is of dimension zero. It is therefore crucial to know when its dimension is positive.

Problem 10.5 (T. Hara, T. Kitayama). *For a natural number n greater than or equal to three, find a sufficient condition for the SL_n -character variety to be of dimension greater than or equal to one (as practical as possible).*

Here we limit ourselves to topics around topological properties of essential tribranched surfaces for want of space. We shall deal with problems and questions concerning actions of 3-manifold groups from the arithmetic viewpoint in [22].

11 Invariants of homology 3-spheres motivated by the Chern-Simons perturbation theory

(Tatsuro Shimizu)

We denote by Z^{KKT} the invariant of homology 3-spheres defined by G. Kuperberg and D. Thurston in [32] motivated by the Chern-Simons perturbation theory. T. Watanabe’s invariant Z^{FW} [62] and the invariant \tilde{Z} of [54] give alternative constructions of Z^{KKT} . Let Z^{LMO} be the LMO invariant [34].

Question 11.1. $Z^{\text{KKT}} = Z^{\text{LMO}}$ for rational homology 3-spheres?

A remarkable progress toward this question is given by D. Moussard. She proved in [46] that Z^{LMO} and Z^{KKT} have same ability to distinguish two rational homology 3-spheres in the sense that, for rational homology 3-spheres M and N with $|H_1(M; \mathbb{Z})| = |H_1(N; \mathbb{Z})|$ and for any $n \in \mathbb{N}$,

$$(Z_k^{\text{LMO}}(M) = Z_k^{\text{LMO}}(N) \text{ for all } k \leq n) \Leftrightarrow (Z_k^{\text{KKT}}(M) = Z_k^{\text{KKT}}(N) \text{ for all } k \leq n).$$

Let Y be a rational homology 3-sphere. The topological invariant $Z_n^{\text{KKT}}(Y)$ is a sum of the principal term depending on a framing τ of Y and the correction term to cancel out the ambiguity of the choice of τ . The correction term is given by $\delta_n \sigma_Y(\tau)$, where $\sigma_Y(\tau)$ is the signature defect of τ and δ_n is a constant independent of τ and

Y ; see [36] for the definition of δ_n . Kuperberg and Thurston conjectured in [32] that this correction term is vanishing for any $n > 1$.

Conjecture 11.2 ([32, Conjecture 6]). $\delta_n = 0$ for any $n > 1$.

The next question may be related to the singularity theory of smooth maps. Let X be a closed compact oriented 4-manifold with a metric such that $\chi(X) = 0$, where $\chi(X)$ is the Euler characteristic of X . Take a unit vector field γ on X and denote by $T^\nu X$ the normal bundle of γ in TX . Let β_1, β_2 and β_3 be “generic” vector fields of $T^\nu X$. For generic $\beta_1, \beta_2, \beta_3$, the set $\{x \in X \mid \dim\langle\beta_1(x), \beta_2(x), \beta_3(x)\rangle = 1\} \subset X$ has a structure of a compact oriented 0-dimensional manifold. Here $\langle\beta_1(x), \beta_2(x), \beta_3(x)\rangle$ is the vector subspace of $(T^\nu X)_x$ spanned by $\beta_1(x), \beta_2(x)$ and $\beta_3(x)$. So we can count the number of point of this set with sign. We denote it by $\langle\langle\beta_1, \beta_2, \beta_3\rangle\rangle \in \mathbb{Z}$. The construction of the correction term of \tilde{Z} or Z^{FW} implies (see Appendix of [54]) that $\langle\langle\beta_1, \beta_2, \beta_3\rangle\rangle = 3 \text{Sign}(X)$ for any generic $\beta_1, \beta_2, \beta_3$. It follows from this fact and $\chi(X) = 0$ that $\langle\langle\beta_1, \beta_2, \beta_3\rangle\rangle$ is divisible by 6.

Question 11.3 (T. Shimizu). *What is a topological interpretation of a reason why $\langle\langle\beta_1, \beta_2, \beta_3\rangle\rangle \in 6\mathbb{Z}$?*

References

- [1] Bae, Y., Park, C. Y., *An upper bound of arc index of links*, Math. Proc. Camb. Phil. Soc. **129** (2000) 491–500.
- [2] Belyĭ, G. V., *Galois extensions of a maximal cyclotomic field*, (Russian) Izv. Akad. Nauk SSSR Ser. Mat. **43** (1979) 267–276, 479.
- [3] Bergeron, N., Linnell, P., Lück, W., Sauer, R., *On the growth of Betti numbers in p -adic analytic towers*, arXiv:1204.3298v3 (2013).
- [4] Birman, J. S., *Braids, links, and mapping class groups*, Annals of Mathematics Studies, **82**. Princeton University Press, Princeton, N.J.; University of Tokyo Press, Tokyo, 1974.
- [5] Birman, J. S., Lin, X.-S., *Knot polynomials and Vassiliev’s invariants*, Invent. Math. **111** (1993) 225–270.
- [6] Bridson, M. R., Haefliger, A., *Metric spaces of non-positive curvature*, Grundlehren der Mathematischen Wissenschaften **319**, Springer-Verlag, Berlin, 1999.
- [7] Calegari, F., Emerton, M., *Mod- p cohomology growth in p -adic analytic towers of 3-manifolds*, Groups Geom. Dyn. **5** (2011) 355–366.
- [8] Carter, J. S., Jelsovsky, D., Kamada, S., Langford, L., Saito, M., *Quandle cohomology and state-sum invariants of knotted curves and surfaces*, Trans. Amer. Math. Soc. **355**(10) (2003) 3947–3989.
- [9] Corson, J. M., *Complexes of groups*, Proc. London Math. Soc. (3) **65** (1992) 199–224.
- [10] Cromwell, P. R., *Embedding knots and links in an open book I: Basic properties*, Topology Appl. **64** (1995) 37–58.
- [11] Culler, M., Shalen, P. B., *Varieties of group representations and splittings of 3-manifolds*, Ann. of Math. (2) **117** (1983) 109–146.

- [12] Dehornoy, P., *Braids and self-distributivity*, Progress in Mathematics **192**, Birkhäuser Verlag, Basel, 2000.
- [13] ———, *Laver's results and low-dimensional topology*, ArXiv e-prints, January 2014.
- [14] Dehornoy, P., Lebed, V., *Two- and three-cocycles for Laver tables*, To appear in J. Knot Theory Ramifications, 2014.
- [15] Drápal, A., *Finite left distributive groupoids with one generator*, Internat. J. Algebra Comput. **7(6)** (1997) 723–748.
- [16] Etnyre, J. B., Honda, K., *Knots and contact geometry I: torus knots and the figure eight knot*, J. Symplectic Geometry **1** (2001) 63–120.
- [17] Fenn, R., Rourke, C., Sanderson, B., *Trunks and classifying spaces*, Appl. Categ. Structures **3(4)** (1995) 321–356.
- [18] Furusho, H., *Galois action on knots I: Action of the absolute Galois group*, preprint arXiv:1211.5469.
- [19] Goussarov, M., *Finite-type invariants are presented by Gauss diagram formulas*, 1998. Translated from Russian by O. Viro.
- [20] Green, J., *A table of virtual knots*, <http://www.math.toronto.edu/drorbn/Students/GreenJ>
- [21] Greenberg, R., *Iwasawa theory—past and present*, Class field theory—its centenary and prospect (Tokyo, 1998), 335–385, Adv. Stud. Pure Math. **30**, Math. Soc. Japan, Tokyo, 2001.
- [22] Hara, T., *Concerning actions of 3-manifold groups: from topological and arithmetic viewpoints*, RIMS Kōkyūroku, this volume.
- [23] Hara, T., Kitayama, T., *Character varieties of higher dimensional representations and splittings of 3-manifolds*, preprint in preparation (2013).
- [24] Hillman, J., *Algebraic invariants of links*, Series on Knots and Everything **32**, World Scientific Publishing Co., Inc., River Edge, NJ, 2002.
- [25] Hillman, J., Matei, D., Morishita, M., *Pro- p link groups and p -homology groups*, Primes and knots, 121–136, Contemp. Math. **416**, Amer. Math. Soc., Providence, RI, 2006.
- [26] Ishii, A., *The pole diagram and the Miyazawa polynomial*, Internat. J. Math. **19** (2008) 193–207.
- [27] Jin, G. T., Park, W. K., *Prime knots whose arc index is smaller than the crossing number*, J. Knot Theory Ramifications **21(10)** (2012) 1655–1672.
- [28] Kadokami, T., Mizusawa, Y., *Iwasawa type formula for covers of a link in a rational homology sphere*, J. Knot Theory Ramifications **17** (2008) 1199–1221.
- [29] Kadokami, T., Mizusawa, Y., *On the Iwasawa invariants of a link in the 3-sphere*, Kyushu J. Math. **67** (2013) 215–226.
- [30] Kauffman, L. H., *Virtual knot theory*, Europ. J. Combinatorics, **20** (1999) 663–690.
- [31] Kozlov, D., *Combinatorial algebraic topology*, Algorithms and Computation in Mathematics **21**. Springer, Berlin, 2008.
- [32] Kuperberg, G., Thurston, D. P., *Perturbative 3-manifold invariants by cut-and-paste topology*, arXiv:math/9912167.

- [33] Laver, R., *On the algebra of elementary embeddings of a rank into itself*, Adv. Math. **110**(2) (1995) 334–346.
- [34] Le, T. T. Q., Murakami, J., Ohtsuki, T., *On a universal perturbative invariant of 3-manifolds*, Topology **37** (1998) 539–574.
- [35] Lee, H. J., Takioka, H., *On the arc index of cable links*, preprint.
- [36] Lescop, C., *On the Kontsevich-Kuperberg-Thurston construction of a configuration-space invariant for rational homology 3-spheres*, arXiv:math/0411088.
- [37] Maclachlan, C., Reid, A.W., *The arithmetic of hyperbolic 3-manifolds*, Graduate Texts in Mathematics **219**. Springer-Verlag, New York, 2003.
- [38] Matsushita, T., *r-fundamental groups of graphs*, arXiv 1301.7217
- [39] Mazur, B., *Remarks on Alexander polynomial* (unpublished manuscript), 1964, http://www.math.harvard.edu/~mazur/papers/alexander_polynomial.pdf
- [40] Miyazawa, Y., *A multivariable polynomial invariant for virtual knots and links*, J. Knot Theory Ramifications **17** (2008) 1311–1326.
- [41] Morel, F., \mathbb{A}^1 -algebraic topology over a field, Lecture Notes in Mathematics **2052**. Springer, Heidelberg, 2012.
- [42] Morishita, M., *Primes and knots (Sosû to musubime)* (in Japanese), Have fun with mathematics (Sûgaku no tanoshimi), 2004 Autumn, Nippon Hyoron Sha Co., Ltd., 125–144.
- [43] ———, *Knots and primes. An introduction to arithmetic topology*, Universitext. Springer, London, 2012.
- [44] Mortier, A., *Finite-type 1-cocycles of knots and virtual knots given by Polyak-Viro formulas*, Submitted. Available at <https://sites.google.com/site/mortier2x0/home/publications-thesis-and-preprints>
- [45] Morton, H. R., Beltrami, E., *Arc index and the Kauffman polynomial*, Math. Proc. Camb. Phil. Soc. **123** (1998) 41–48.
- [46] Moussard, D., *Finite type invariants of rational homology 3-spheres*, Algebr. Geom. Topol. **12** (2012) 2389–2428.
- [47] Nakamura, T., Nakanishi, Y., Satoh S., Tomiyama, Y., *The state number of a knot*, J. Knot Theory Ramifications **23** (2014) 1450016 (27 pages).
- [48] Nakamura, T., Nakanishi, Y., Satoh, S., *On knots with no 3-state*, to appear in the Proceedings of International Conference on Topology and Geometry 2013, joint with the 6th Japan-Mexico Topology Symposium, Topology Appl.
- [49] Nosaka, T., *Longitudes in SL_2 -representations of link groups and Milnor-Witt K_2 -groups of fields*, preprint.
- [50] Perbet, P., *Sur les invariants d’Iwasawa dans les extensions de Lie p-adiques*, Algebra Number Theory **5** (2011) 819–848.
- [51] Polyak, M., Viro, O., *Gauss diagram formulas for Vassiliev invariants*, Internat. Math. Res. Notices 1994, no. 11, 445ff., approx. 8 pp. (electronic).
- [52] ———, *On the Casson knot invariant*, J. Knot Theory Ramifications **10** (2001) 711–738.

- [53] Sakai, K., *An integral expression of the first nontrivial one-cocycle of the space of long knots in \mathbb{R}^3* , Pacific J. Math. **250** (2011) 407–419.
- [54] Shimizu, T., *An invariant of rational homology 3-spheres via vector fields*, arXiv:1311.1863.
- [55] Smedberg, M., *A dense family of well-behaved finite monogenerated left-distributive groupoids*, Arch. Math. Logic **52(3-4)** (2013) 377–402.
- [56] Thistlethwaite, M. B., *On the Kauffman polynomial of an adequate link*, Invent. Mat. **93** (1998) 258–296.
- [57] Tomiyama, Y., *Kasou-musubime no kouten-suu to suteito-suu* (in Japanese), *Crossing numbers and state number of virtual knot*, Master Thesis, Kobe University (2010).
- [58] Traczyk, P., *A new proof of Markov’s braid theorem*, Knot theory (Warsaw, 1995), 409–419, Banach Center Publ. **42**, Polish Acad. Sci., Warsaw, 1998.
- [59] Vassiliev, V.A., *Cohomology of knot spaces*, “Theory of singularities and its applications” (V.I. Arnold ed.) Adv. Soviet Math. **1**, Amer. Math. Soc., Providence, RI (1990) 23–69.
- [60] Vogel, P., *Representation of links by braids: a new algorithm*, Comment. Math. Helv. **65** (1990) 104–113.
- [61] Washington, L., C., *Introduction to cyclotomic fields (Second edition)*, Graduate Texts in Mathematics **83**, Springer-Verlag, New York, 1997.
- [62] Watanabe, T., *Higher order generalization of Fukaya’s Morse homotopy invariant of 3-manifolds I. Invariants of homology 3-spheres*, arXiv:1202.5754.
- [63] Weibel, C.A., *The K-book. An introduction to algebraic K-theory* Graduate Studies in Mathematics **145**. American Mathematical Society, Providence, RI, 2013.
- [64] Yamada, S., *The minimal number of Seifert circles equals the braid index of a link*, Invent. Math. **89** (1987) 347–356.
- [65] Zickert, C., *The volume and Chern-Simons invariant of a representation*, Duke Math. J. **150** (2009) 489–532.