

Normal Forms for Certain Singularities of Smooth Map-Germs

市川文男

都立大 理

Fumio ICHIKAWA

Tokyo Metropolitan University

In the theory of singularity of smooth mapping, finite determinacy has been studied by many authors [6]. In [4], J.Mather gave a complete characterization of finite determinacy, but in general it is very difficult to check whether a given map-germ $f : (\mathbb{R}^n, 0) \longrightarrow (\mathbb{R}^p, 0)$ is finitely determined or not except for stable singularities or the case $p = 1$. In this paper we give some classification of smooth mappings $f : (\mathbb{R}^n, 0) \longrightarrow (\mathbb{R}^2, 0)$ by an elementary method.

In §1 we recall J.Mather's theorem on finite determinacy.

In §2 we prove what we call Normal Form Theorem (Theorem 2.1, Theorem 2.5 and Theorem 2.7). In Theorem 2.1 we give normal forms of function-germs. As its immediate corollaries we obtain the Morse lemma (Example 2.3) and the splitting lemma for functions (Example 2.4). These corollaries are well-known and have nothing new, however from these examples show how convenient and efficient it will be if we generalize Theorem 2.1 to the case of map-germs. This is what we have done. (Theorem 2.5, Theorem 2.6).

In §3 we prove the Splitting Lemmas for map-germs of corank 1 (Theorem 3.2 and Theorem 3.3) using the normal forms obtained in §2.

In §4 as an application of our normal forms and splitting lemmas, we classify finitely determined map-germs of R^n into R^2 of corank 1 whose 3-jets are non-trivial. An estimation of order of their determinacy is given as well. From the splitting lemmas developed in §3, the classification and the estimation of order of determinacy of these map-germs are reduced to those of map-germs of plane to plane. Then they are carried out in a rather elementary way.

§1. Preliminaries.

In this section we recall Mather's theorem. Let \mathcal{E}_n be the ring of C^∞ -function germs $(R^n, 0) \rightarrow R$ and \mathfrak{M} be the maximal ideal of \mathcal{E}_n . By $\mathcal{E}(n, p)$ we denote the set of C^∞ -map germs $f : (R^n, 0) \rightarrow (R^p, 0)$. Two map-germs $f, g \in \mathcal{E}(n, p)$ are k -jet equivalent if the all partial derivatives of order $\leq k$ at the origin are equal. We denote by $J^k(n, p)$ the k -jet equivalent classes and we call it k -jet space. There is a canonical projection $j^k : \mathcal{E}(n, p) \rightarrow J^k(n, p)$.

Let $L(n)$ (resp. $L(p)$) be the group of C^∞ -local diffeomorphisms of $(R^n, 0)$ (resp. $(R^p, 0)$). The group $\mathcal{A} = L(n) \times L(p)$ acts on $\mathcal{E}(n, p)$ as follows; $(\varphi, \psi) \cdot f = \psi \circ f \circ \varphi$ where $(\varphi, \psi) \in \mathcal{A}$ and $f \in \mathcal{E}(n, p)$.

DEFINITION 1.1. A map-germ $f \in \mathcal{E}(n,p)$ is called k-determined if for any $g \in \mathcal{E}(n,p)$ such that $j^k f = j^k g$, f and g are contained in the same \mathcal{A} -orbit. A map-germ f is called finitely determined if there is a positive integer k such that f is k -determined.

DEFINITION 1.2. A map-germ $f \in \mathcal{E}(n,p)$ is called C^0 -k-determined if for any $g \in \mathcal{E}(n,p)$ such that $j^k f = j^k g$, there exist homeomorphisms $h : (R^n, 0) \rightarrow (R^n, 0)$ and $h' : (R^p, 0) \rightarrow (R^p, 0)$ such that $g = h' \circ f \circ h$.

DEFINITION 1.3. For a C^∞ -map germ f , a vector field along f is a C^∞ -map germ $\zeta : (R^n, 0) \rightarrow TR^p$ such that $\pi \circ \zeta = f$ where π is a projection $TR^p \rightarrow R^p$. By $\theta(f)$ we denote the set of all vector fields along f . Let $\theta(n)$ (resp. $\theta(p)$) denote the set of all C^∞ -vector fields germs at $(R^n, 0)$ (resp. $(R^p, 0)$). We define $tf : \theta(n) \rightarrow \theta(f)$ and $wf : \theta(p) \rightarrow \theta(f)$ by

$$tf(\zeta) = Tf(\zeta), \quad (\zeta \in \theta(n)) \text{ and}$$

$$wf(\eta) = \eta \circ f, \quad (\eta \in \theta(p)).$$

THEOREM 1.4 (Mather [4]). A C^∞ -map germ $f : (R^n, 0) \rightarrow (R^p, 0)$ is finitely determined if and only if there is a positive integer k such that

$$tf(\theta(n)) + wf(\theta(p)) \supset \pi^k \theta(f).$$

§2. Elementary normal form theorem.

From Mather's theorem, we easily see that the classification of finitely determined C^∞ -map germs can be reduced to that of formal mappings. Thus, in this section we consider formal mappings.

Let K be the field of real numbers R or complex numbers C . We denote by H_j the vector space of homogeneous polynomials of degree j and by \hat{m} the maximal ideal of $K[[x_1, \dots, x_n]]$. For a formal power series $f \in K[[x_1, \dots, x_n]]$, we represent f as $f = f_{(k)} + f_{(k+1)} + \dots$, $f_{(j)} \in H_j$ ($j \geq k$). By $\hat{m}^2 \langle \partial f_{(k)} / \partial x \rangle$ we denote the ideal $\hat{m}^2 \langle \partial f_{(k)} / \partial x_1, \dots, \partial f_{(k)} / \partial x_n \rangle$ of $K[[x_1, \dots, x_n]]$. We set $B_j = \hat{m}^2 \langle \partial f_{(k)} / \partial x \rangle \cap H_j$ and we denote by G_j a complementary linear subspace of B_j in H_j ($j \geq k+1$).

THEOREM 2.1. Let the notations be as above. Then there exists a formal diffeomorphism \mathcal{F} such that

$$f \circ \mathcal{F} = f_{(k)} + g_{(k+1)} + g_{(k+2)} + \dots$$

where $g_{(j)} \in G_j$ ($j \geq k+1$).

LEMMA 2.2. Let \mathcal{F}_j ($j \geq 2$) be a formal diffeomorphism such that $\mathcal{F}_j(x_i) = x_i + h_i^j$ where $h_i^j \in H_j$ ($i=1, \dots, n$). Then

$$f_{(k)} \circ \mathcal{F}_j = f_{(k)} + h_1^j (\partial f_{(k)} / \partial x_1) + \dots + h_n^j (\partial f_{(k)} / \partial x_n) + \text{higher terms.}$$

PROOF. It is enough to prove the case where $f_{(k)}$ is a monomial. Suppose that $f_{(k)} = x_1^{\alpha_1} \dots x_n^{\alpha_n}$. Then

$$\begin{aligned}
 f_{(k)} \circ \varphi_j &= (x_1 + h_1^j)^{\alpha_1} \dots (x_n + h_n^j)^{\alpha_n} \\
 &= (x_1^{\alpha_1} + \alpha_1 x_1^{\alpha_1-1} h_1^j + \text{higher terms}) \dots (x_n^{\alpha_n} + \alpha_n x_n^{\alpha_n-1} h_n^j \\
 &\quad + \text{higher terms}) \\
 &= f_{(k)} + h_1^j (\partial f_{(k)} / \partial x_1) + \dots + h_n^j (\partial f_{(k)} / \partial x_n) \\
 &\quad + \text{higher terms.} \quad \text{Q.E.D.}
 \end{aligned}$$

PROOF OF THEOREM 2.1. First we decompose $f_{(k+1)}$ into $b_{(k+1)} + g_{(k+1)}$ where $b_{(k+1)} \in B_{k+1}$ and $g_{(k+1)} \in G_{k+1}$. From the definition of B_{k+1} , there are $h_1^2, \dots, h_n^2 \in H_2$ such that $b_{(k+1)} = h_1^2 (\partial f_{(k)} / \partial x_1) + \dots + h_n^2 (\partial f_{(k)} / \partial x_n)$. We take a formal diffeomorphism φ_2 given by $\varphi_2(x_i) = x_i - h_i^2$ ($i=1, \dots, n$). Then, from lemma 2.2 we have

$$f \circ \varphi_2 = f_{(k)} + g_{(k+1)} + f'_{(k+2)} + \dots$$

Next we decompose $f'_{(k+2)}$ into $b_{(k+2)} + g_{(k+2)}$ where $b_{(k+2)} \in B_{k+2}$ and $g_{(k+2)} \in G_{k+2}$. And we take a formal diffeomorphism φ_3 such that

- (i) $\varphi_3(x_i) = x_i - h_i^3$, $h_i^3 \in H_3$ ($i=1, \dots, n$)
- (ii) $b_{(k+2)} = h_1^3 (\partial f_{(k)} / \partial x_1) + \dots + h_n^3 (\partial f_{(k)} / \partial x_n)$.

$$\text{Then } f \circ \varphi_2 \circ \varphi_3 = f_{(k)} + g_{(k+1)} + g_{(k+2)} + f''_{(k+3)} + \dots$$

Thus, inductively we can take formal diffeomorphisms $\varphi_2, \varphi_3, \dots$ and we define φ as ^{the} limit of $\{\varphi_2 \circ \varphi_3 \circ \dots \circ \varphi_i\}$ (this makes sense). Then $f \circ \varphi = f_{(k)} + g_{(k+1)} + g_{(k+2)} + \dots$. This completes the proof.

REMARK. Theorem 2.1 is an analogy of Takens's normal form theorem for vector field [5].

EXAMPLE 2.3 (Morse lemma). Let f be in the form $\pm x_1^2 \pm \dots \pm x_n^2 +$ higher terms. Then $\hat{m}^2 \langle \partial f_{(2)} / \partial x \rangle = \hat{m}^3$ and $G_j = \{0\}$ ($j \geq 3$). Thus ^{the} normal form of f is $\pm x_1^2 \pm \dots \pm x_n^2$ i.e. f is 2-determined.

EXAMPLE 2.4 (Splitting theorem). Let f be in the form $\pm x_1^2 \pm \dots \pm x_i^2 +$ higher terms. Then $\hat{m}^2 \langle \partial f_{(2)} / \partial x \rangle = \hat{m}^2 \langle x_1, \dots, x_i \rangle$. Thus we can take the vector space of homogeneous polynomials of degree j of variables x_{i+1}, \dots, x_n as G_j ($j \geq 3$). Therefore the normal form of f is given by $\pm x_1^2 \pm \dots \pm x_i^2 + g(x_{i+1}, \dots, x_n)$ where order of $g \geq 3$.

Now, let $\hat{\mathcal{E}}(n, p)$ be the set of formal mappings $f : (K^n, 0) \rightarrow (K^p, 0)$. We identify $\hat{\mathcal{E}}(n, p)$ with $\underbrace{\hat{m} \oplus \dots \oplus \hat{m}}_p$ and in the natural way we regard $\hat{\mathcal{E}}(n, p)$ as $K[[x_1, \dots, x_n]]$ -module. We denote by $\mathcal{E}_i(n, p)$ the set of homogeneous polynomial mappings of degree i , i.e. $\mathcal{E}_i(n, p) = \underbrace{H_i \oplus \dots \oplus H_i}_p$. For a formal mapping $f = f_{(k)} + f_{(k+1)} + \dots$ ($f_{(j)} \in \mathcal{E}_j(n, p)$, $j \geq k$), we denote by $\hat{m}^2 \langle \partial f_{(k)} / \partial x \rangle$ the submodule $\hat{m}^2 \langle \partial f_{(k)} / \partial x_1, \dots, \partial f_{(k)} / \partial x_n \rangle$ of $\hat{\mathcal{E}}(n, p)$. We set $B_j = \hat{m}^2 \langle \partial f_{(k)} / \partial x \rangle \cap \mathcal{E}_j(n, p)$ and we denote by G_j a ^{complementary} linear subspace of B_j in $\mathcal{E}_j(n, p)$ ($j \geq k+1$).

THEOREM 2.5. Let the notations be as above. Then there exists a formal diffeomorphism \mathcal{F} such that

$$f \circ \mathcal{F} = f_{(k)} + g_{(k+1)} + g_{(k+2)} + \dots$$

where $g_{(j)} \in G_j$ ($j \geq k+1$).

The proof is quite same as the proof of Theorem 2.1.

EXAMPLE 2.6. For a formal mapping $f = f_{(2)} + f_{(3)} + \dots$
 $: (K^n, 0) \rightarrow (K^2, 0)$, we assume that $f_{(2)} = (\pm x_1^2 \pm \dots \pm x_n^2,$
 $a_1 x_1^2 + \dots + a_n x_n^2)$ where $a_i \pm a_j \neq 0$ for $i \neq j$. Then,
 obviously we can take a linear subspace of $(\{0\} \oplus H_j)$ as G_j .
 Moreover, $x_i (\partial f_{(2)} / \partial x_j) \pm x_j (\partial f_{(2)} / \partial x_i) = (0, 2(a_j \pm a_i)x_i x_j)$.
 Thus we can take $\langle (0, x_1^j), \dots, (0, x_n^j) \rangle_K$ as G_j . Therefore
 the normal form of f is given by

$$(\pm x_1^2 \pm \dots \pm x_n^2, a_1 x_1^2 + \dots + a_n x_n^2 + \sum_{j \geq 3} b_1^j x_1^j + \dots + \sum_{j \geq 3} b_n^j x_n^j).$$

Now, for a formal mapping f of which Jacobian has rank r ,
 from ^{the} implicit function theorem without loss of generality we can
 assume that f is in the form $f = (x_1, \dots, x_r, f^{r+1}, \dots, f^p)$
 where $f^s \in \hat{\mathcal{M}}^2$ ($s=r+1, \dots, p$). In this case we set $\tilde{f} = (f^{r+1},$
 $\dots, f^p) \in \hat{\mathcal{E}}(n, p-r)$. We represent \tilde{f} as $\tilde{f}_{(k)} + \tilde{f}_{(k+1)} + \dots$ where
 $\tilde{f}_{(j)} \in \mathcal{E}_j(n, p-r)$ ($j \geq k$). We set $\tilde{B}_j = \hat{\mathcal{M}}^2 \langle \partial \tilde{f}_{(k)} / \partial x_{r+1}, \dots,$
 $\partial \tilde{f}_{(k)} / \partial x_n \rangle \cap \mathcal{E}_j(n, p-r)$ and we denote by \tilde{G}_j a complimentary
 linear subspace of \tilde{B}_j in $\mathcal{E}_j(n, p-r)$.

THEOREM 2.7. Let the notations be as above. Then there
exists a formal diffeomorphism \mathcal{G} such that

$$f \circ \mathcal{G} = (x_1, \dots, x_r, \tilde{f}_{(k)} + \tilde{g}_{(k+1)} + \tilde{g}_{(k+2)} + \dots)$$

where $\tilde{g}_{(j)} \in \tilde{G}_j$ ($j \geq k+1$).

PROOF. It is enough to take formal diffeomorphisms \mathcal{G}_j
 such that $\mathcal{G}_j(x_i) = x_i$ ($i=1, \dots, r$) and $\mathcal{G}_j(x_i) = x_i + h_i^j$
 ($i=r+1, \dots, n$) for each $j \geq 3$. The other part of proof is
 the same as the proof of Theorem 2.1. This completes the proof.

§3. Generalized splitting theorem.

In this section we assume that $n \geq p$.

PROPOSITION 3.1. A two-jet $z \in J^2(n, p)$ of which Jacobian has rank $p-1$ is \mathcal{A}^2 -equivalent to the following two-jet;

$$(x_1, \dots, x_{p-1}, x_1 x_p + \dots + x_i x_{p+i-1} + Q_{j+1}) \quad (*)$$

where $Q_{j+1} = x_{j+1}^2 + \dots + x_n^2$ and $0 \leq i \leq p-1$, $p-1 \leq j \leq n$, $p+i-1 \leq j$ and i, j are uniquely determined by z .

PROOF. Without loss of generality we can assume that $z = (x_1, \dots, x_{p-1}, f)$ where f is a homogeneous polynomial of degree two. By the right linear transformation we can assume that $f(0, \dots, 0, x_p, \dots, x_n) = Q_{j+1}$. Thus f is in the form $f(x_1, \dots, x_n) = h(x_1, \dots, x_{p-1}) + (\sum_{s=1}^{p-1} a_{s,p} x_s) x_p + \dots + (\sum_{s=1}^{p-1} a_{s,j} x_s) x_j + (\sum_{s=1}^{p-1} a_{s,j+1} x_s) x_{j+1} + \dots + (\sum_{s=1}^{p-1} a_{s,n} x_s) x_n + Q_{j+1}$.

By the right transformation \mathcal{G} such that $\mathcal{G}(x_t) = x_t$ ($t=1, \dots, j$) and $\mathcal{G}(x_t) = x_t + (1/2)(\sum_{s=1}^{p-1} a_{s,t} x_s)$ ($t=j+1, \dots, n$), we

can eliminate the terms $(\sum a_{s,j} x_s) x_j, \dots, (\sum a_{s,n} x_s) x_n$.

And we can eliminate $h(x_1, \dots, x_{p-1})$ by the left transformation

\mathcal{Y} such that $\mathcal{Y}(y_t) = y_t$ ($t=1, \dots, p-1$) and $\mathcal{Y}(y_p) = y_p -$

$h(y_1, \dots, y_{p-1})$ where (y_1, \dots, y_p) is the local coordinates

of $(K^p, 0)$. Next we assume that in $\{ \sum a_{s,p} x_s, \dots, \sum a_{s,j} x_s \}$

the first i functions are linearly independent and the other

functions are written by linear combinations of them. Then

there is a right linear transformation \mathcal{G}' of x_1, \dots, x_{p-1}

such that z is equivalent to

$$(\mathcal{G}'(x_1), \dots, \mathcal{G}'(x_{p-1}), x_1 x_p + \dots + x_i x_{p+i-1} + (\sum_{s=1}^i b_{s,p+i} x_s) x_{p+i} + \dots + (\sum_{s=1}^i b_{s,j} x_s) x_j + Q_{j+1}).$$

By the left linear transformation of y_1, \dots, y_{p-1} , ^{the} above is equivalent to

$$(x_1, \dots, x_{p-1}, x_1 x_p + \dots + x_i x_{p+i-1} + (\sum b_{s,p+i} x_s) x_{p+i} + \dots + (\sum b_{s,j} x_s) x_j + Q_{j+1}).$$

We rewrite the above p -th component as follows

$$(x_p + \sum_{t=p+i}^j b_{1,t} x_t) x_1 + \dots + (x_{p+i-1} + \sum_{t=p+i}^j b_{i,t} x_t) x_i + Q_{j+1}.$$

Finally, by the right linear transformation \mathcal{G}'' such that

$$\mathcal{G}''(x_r) = x_r \quad (r=1, \dots, p-1, p+i, \dots, n) \quad \text{and} \quad \mathcal{G}''(x_r) = x_r -$$

$$\left(\sum_{t=p+i}^j b_{r-p+1,t} x_t \right) \quad (r=p, \dots, p+i-1), \quad \text{we have the normal form (*).$$

The number j is determined by the contact class of z and the number i is determined by the codimension of \mathcal{A}^2 -orbit of z for fixed j (the definition of contact class can be seen in [4],[6]). This completes the proof.

THEOREM 3.2. Let the two jet of formal mapping $f \in \hat{\mathcal{E}}(n,p)$ be in the form (*). Then there exists a formal diffeomorphism \mathcal{G} such that

$$f \circ \mathcal{G} = (x_1, \dots, x_{p-1}, x_1 x_p + \dots + x_i x_{p+i-1} + Q_{j+1} + g(x_{i+1}, \dots, x_j))$$

where order of $g \geq 3$.

(**)

PROOF. In Theorem 2.7, we set $r = p-1$ and $k = 2$. Taking the complementary linear subspace of $\hat{\mathcal{M}}^2 \langle \partial f_{(2)} / \partial x_p, \dots, \partial f_{(2)} / \partial x_{p+i-1}, \partial f_{(2)} / \partial x_{j+1}, \dots, \partial f_{(2)} / \partial x_n \rangle = \hat{\mathcal{M}}^2 \langle x_1, \dots, x_i, x_{j+1}, \dots, x_n \rangle$, we obtain the normal form (**). This completes the proof.

The following theorem is an immediate consequence of the Theorem 3.2 and result of du Plessis [1] (3.34).

THEOREM 3.3. Let a formal mapping $f \in \hat{\mathcal{E}}(n,p)$ be in the form (**). We set $\tilde{f} = (x_1, \dots, x_{p-1}, x_1 x_p + \dots + x_i x_{p+i-1} + g(x_{i+1}, \dots, x_j)) \in \hat{\mathcal{E}}(j,p)$. Then f is k-determined if and only if \tilde{f} is k-determined.

§4. Some normal forms.

In this section we consider a C^∞ -mapping $f : (R^n, 0) \rightarrow (R^2, 0)$ of which Jacobian has rank one. Thus we assume that f is in the form $(x_1, g(x_1, \dots, x_n))$ where $g \in \mathcal{M}^2$. Moreover we assume that two jet of $g(x_1, \dots, x_n)$ is in the form $Q_2, x_1x_2 + Q_3$ or Q_3 . Then from Theorem 3.3, the classification of f is reduced to that of the mappings $(R^2, 0) \rightarrow (R^2, 0)$.

Let (x, y) (resp. (X, Y)) be the local coordinates of the source space $(R^2, 0)$ (resp. the target space $(R^2, 0)$). Simply we denote by $(h_1(x, y), h_2(x, y))$ the vector field along f , of the form $h_1(x, y)((\partial/\partial X) \circ f) + h_2(x, y)((\partial/\partial Y) \circ f)$. The following proposition is a corollary of Proposition 3.1.

PROPOSITION 4.1. A two jet $z \in J^2(2, 2)$ of which Jacobian has rank one is \mathcal{A}^2 -equivalent to one of the following:

Notation	A	B	C
Normal form	(x, y^2)	(x, xy)	$(x, 0)$

In the case (A), from Theorem 3.2, the normal form is given by $(x, y^2 + \sum_{k \geq 3} a_k x^k)$. By a left transformation \mathcal{Y} such that $\mathcal{Y}(X) = X$ and $\mathcal{Y}(Y) = Y - \sum_{k \geq 3} a_k X^k$, this is equivalent to (x, y^2) i.e. we have a Whitney's fold singularity which is 2-determined.

In the case (B) the normal form is given by

$$(x, xy + \sum_{k \geq 3} a_k y^k). \quad (B^*)$$

THEOREM 4.2. For a real analytic map germ $f : (R^2, 0) \rightarrow (R^2, 0)$ given by (B^*) , $f(x, y)$ is finitely determined if and only if there is a positive integer k such that $a_k \neq 0$. Moreover for a C^∞ -map germ with ∞ -jet (B^*) let k denote the minimum k such that $a_k \neq 0$. Then $f(x, y)$ is C^0 -k-determined.

PROOF. If for any $k \geq 3$, a_k is zero then $(0, y^k) \notin \text{tf}(\theta(n)) + \text{wf}(\theta(p))$. Thus f is not finitely determined. For the minimum k such that $a_k \neq 0$, by the scalar multiplications of x, y, X and Y we can assume that $a_k = 1$. The singular set $S(f)$ of f is given by $\left\{ x + ky^{k-1} + \sum_{t \geq k+1} a_t y^{t-1} = 0 \right\}$. The set $f^{-1}(\{Y=0\})$ is given by $\left\{ y \left(x + y^{k-1} + \sum_{t \geq k+1} a_t y^{t-1} \right) = 0 \right\}$. Note that from ^(a)theorem on \mathbb{V} -sufficiency (cf. [3,6]) the above sets are determined by the finite jet. We see the topological picture of f by the figure 1 and 2. The figure 1 is the case where k is even. The figure 2 is the case where k is odd. In the figures we denote by thick lines the set $f^{-1}(\{Y=0\})$ and by dotted lines the singular set $S(f)$. From the figures it is obvious that f is C^0 - k -determined. For the real analytic case, from the figure we see that the complexification of f is stable in $U \setminus \{0\}$ where U is a small neighbourhood of 0 in C^n . Thus f is finitely determined (cf. Proposition 1.7 and theorem 2.1 of [6]). This completes the proof.

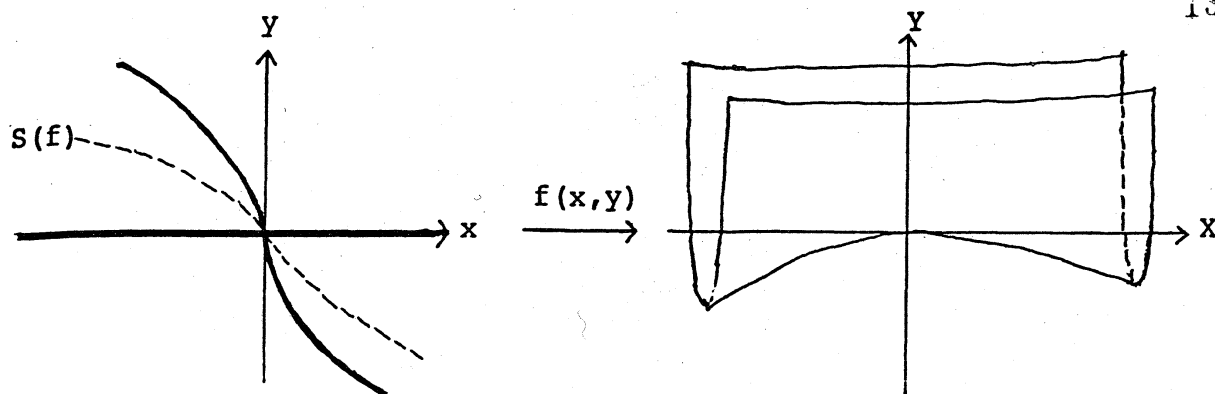

Figure 1.

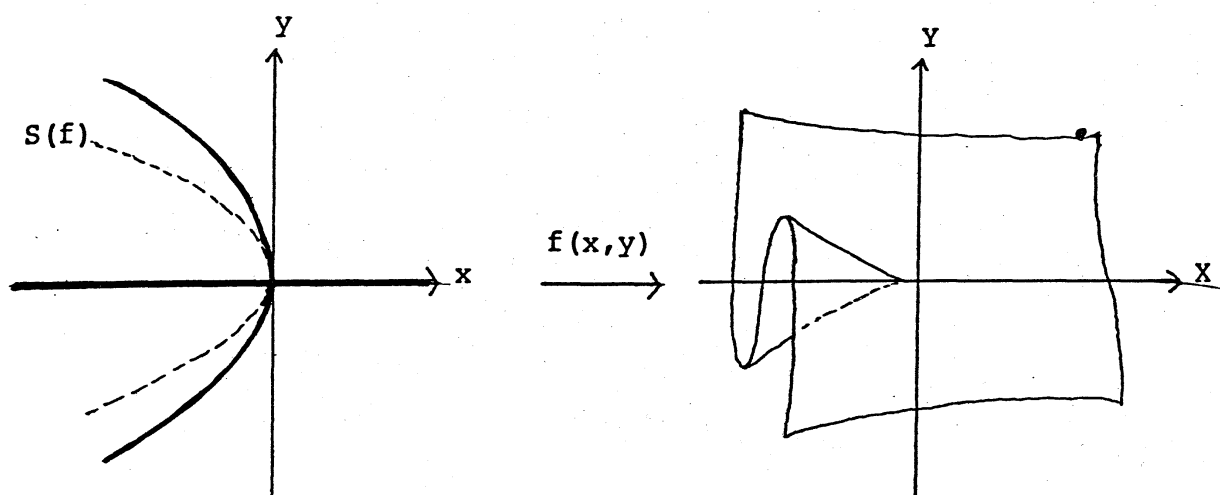

Figure 2.

REMARK. Even for the map-germ $f = (x, xy + y^r)$ it is not easy to determine the minimum number k such that f is k -determined. In [1] du Plessis proved that when $r = 3, 4$ and 5 , f is respectively $3, 4$ and 7 -determined. In general by complicated computations it can be proved that

$$tf(\theta(n)) + wf(\theta(p)) \supset \pi^{r(r-2)} \theta(f).$$

Now, we classify the case (C) in the three jet space.

PROPOSITION 4.3. A three jet $z = (x, ax^3 + bx^2y + cxy^2 + dy^3) \in J^3(2, 2)$ is A^3 -equivalent to one of the following:

Notation	C_1^+	C_1^-	C_2	C_3	C_4	D
Normal form	$(x, y^3 + x^2y)$	$(x, y^3 - x^2y)$	(x, y^3)	(x, xy^2)	(x, x^2y)	$(x, 0)$

PROOF. (i) The case $d \neq 0$. By scalar multiplication of y we assume that $d = 1$. By the right transformation φ such that $\varphi(x) = x$ and $\varphi(y) = y - (c/3)x$, we can eliminate the term cxy^2 and we obtain the form $(x, ax^3 + bx^2y + y^3)$. If $b \neq 0$, then by the scalar multiplications of x and X we can assume that $b = \pm 1$. By the left transformation ψ such that $\psi(x) = x$ and $\psi(y) = y - ax^3$, we obtain the normal form C_1^+ . If $b = 0$, then by the same way, we obtain the normal form C_2 .

(ii) The case $d = 0$ and $c \neq 0$. By the scalar multiplications of x and X , we can assume that $c = 1$, i.e. $(x, ax^3 + bx^2y + xy^2)$. By the right transformation φ such that $\varphi(x) = x$, $\varphi(y) = y - (b/2)x$, we can eliminate the term bx^2y . Finally by the left transformation we obtain the normal form C_3 .

(iii) The case $d = c = 0$ and $b \neq 0$. In this case it is easy to see that z is equivalent to C_4 .

(iv) The case $d = c = b = 0$. Obviously, z is equivalent to D. This completes the proof.

REMARK. The adjacencies of C_1^+ , C_2 , C_3 , C_4 and D are given by

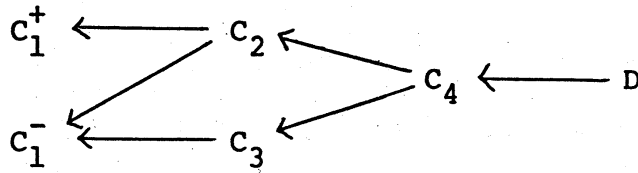

where $C_i \longleftarrow C_j$ means that the closure of C_i contains C_j .

The following propositions 4.4 and 4.5 was proved by du plessis as the examples of finitely determined map-germs in [1]

PROPOSITION 4.4. The map-germs $C_1^{\pm} = (x, y^3 \pm x^2 y)$ are 3-determined.

In the case (C_2) from Theore 2.7 the normal form is given by $(x, y^3 + \sum_{k \geq 3} a_k x^k y + \sum_{k \geq 4} b_k x^k)$. However by the left transformation we can eliminate the term $\sum_{k \geq 4} b_k x^k$. Thus the normal form is given by

$$(x, y^3 + \sum_{k \geq 3} a_k x^k y). \quad (C_2^*)$$

PROPOSITION 4.5. For a C^{∞} -map germ f with ∞ -jet (C_2^*) , f is finitely determined if and only if there is a positive integer k such that $a_k \neq 0$. Moreover, for the minimum k such that $a_k \neq 0$, f is $(k+1)$ -determined.

REMARK. (1) In the case C_1^+ , $f = (x, y^3 + x^2y)$ has an isolated singularity at the origin and f is a topological embedding.

(2) In the case C_1^- , a topological picture of $f = (x, y^3 - x^2y)$ is given by Figure 3.

(3) For $f = (x, y^3 + a_k x^k y)$ by the scalar multiplications of x and y , f is \mathcal{A} -equivalent to $(x, y^3 + x^k y)$. It is easy to see that if k is odd then f is \mathcal{A} -equivalent to $(x, y^3 + x^k y)$ and the topological picture of f is given by Figure 4. In the case where k is even and $f = (x, y^3 + x^k y)$, f has an isolated singularity at the origin. Thus f is a topological embedding. In the case where k is even and $f = (x, y^3 - x^k y)$, the topological picture of f is the same as Figure 3.

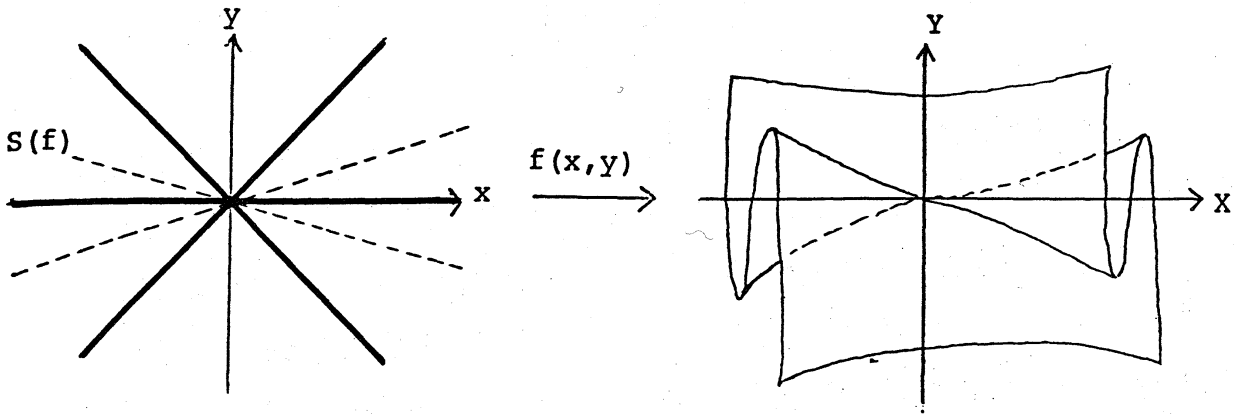

Figure 3.

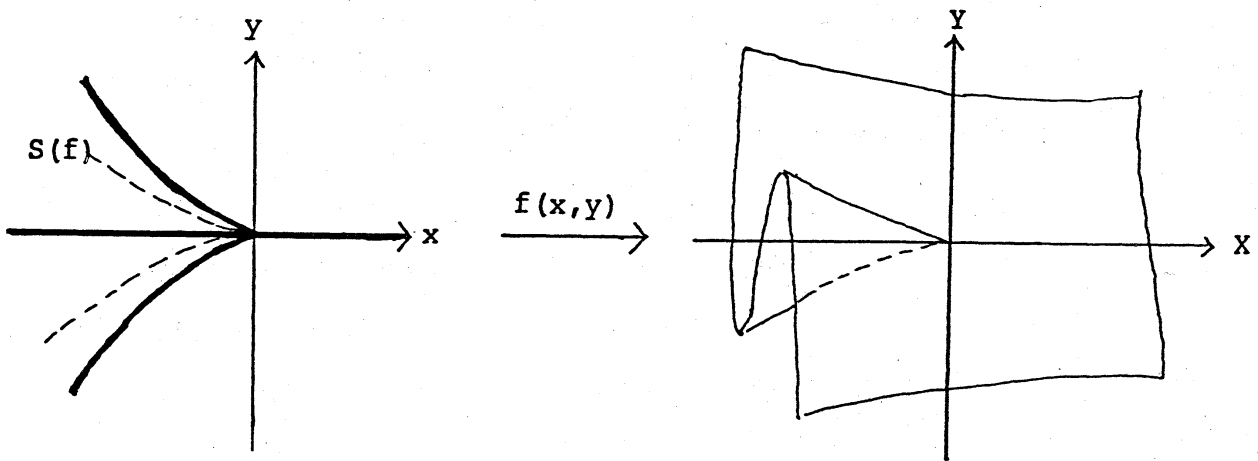

Figure 4.

In the case $C_3; (x, xy^2)$, from Theorem 2.7 and the left transformation we obtain the normal form

$$(x, xy^2 + \sum_{k \geq 4} a_k y^k) \quad (C_3^*)$$

THEOREM 4.6. For the analytic map germ $f(x,y)$ given by (C_3^*) , f is finitely determined if and only if there is a positive odd integer k such that $a_k \neq 0$. For a C^∞ -map germ f with ∞ -jet (C_3^*) let $k < \infty$ be the minimum odd integer such that $a_k \neq 0$. Then, $f(x,y)$ is C^0 - k -determined.

PROOF. Let r denote the minimum integer such that $a_r \neq 0$. The singular set $S(f)$ is given by $\{y(2x + ry^{r-2} + \sum_{t=r+1}^{\infty} a_t y^{t-2}) = 0\}$. And the set $f^{-1}(\{Y=0\})$ is given by $\{y^2(x + y^{r-2} + \sum_{t=r+1}^{\infty} a_t y^{t-2}) = 0\}$. If there is an odd integer k such that $a_k \neq 0$, then $f(\{(x,y) \in S(f); y > 0\}) \cap f(\{(x,y) \in S(f); y < 0\}) = \emptyset$ in a small neighbourhood of 0 . We see the topological picture by the figure 5 and 6. The figure 5 is the case where r is even. The figure 6 is the case where r is odd. From the figures it is obvious that f is C^0 - k -determined. If for any odd number k , $a_k = 0$ and f is finitely determined, then we can assume that f is a polynomial mapping. Then the subsets of critical values $f(\{(x,y) \in S(f); y > 0\})$ and $f(\{(x,y) \in S(f); y < 0\})$ coincide, thus f is not finitely determined. The proof of real analytic case is the same as the proof of Theorem 4.2. This completes the proof.

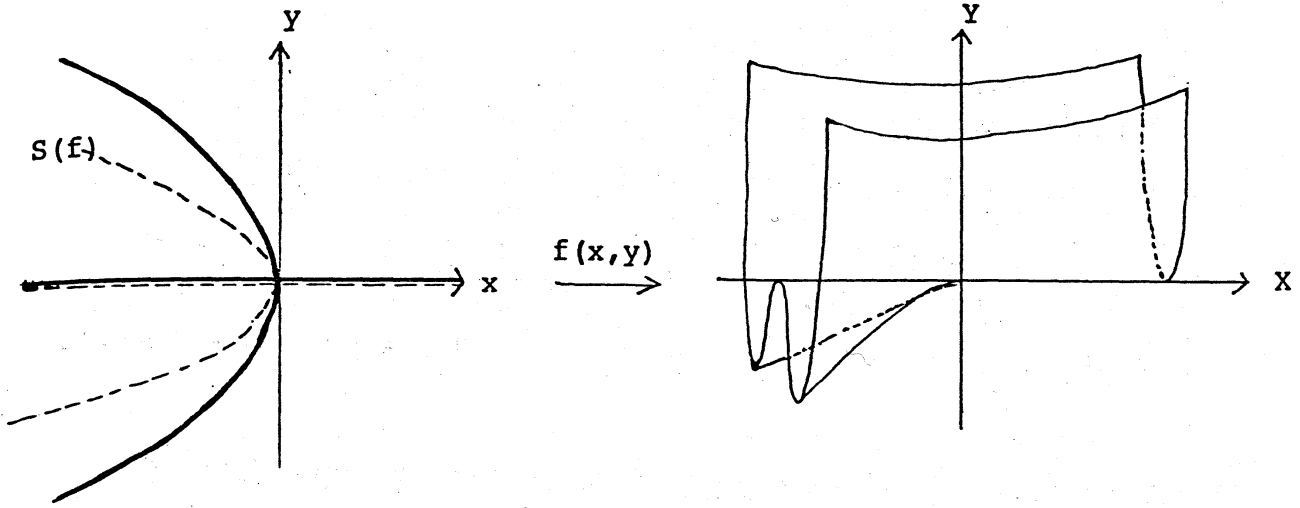

Figure 5.

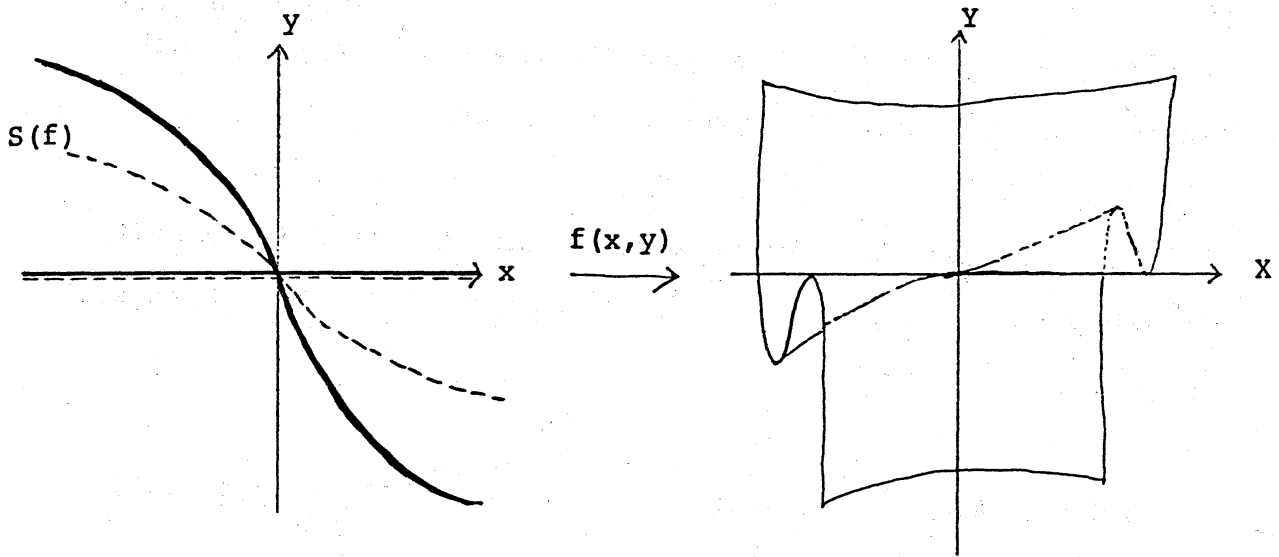

Figure 6.

Finally, we study the case C_4 . From Theorem 2.7 and the left transformation we obtain the following normal form

$$(x, x^2y + \sum_{r \geq s} a_r xy^{r-1} + \sum_{r \geq t} b_r y^r). \quad (C_4^*)$$

Here we assume that $a_s \neq 0$, and $b_t \neq 0$ ($3 \leq s \leq \infty$, $4 \leq t \leq \infty$).

LEMMA 4.7. If a C^∞ -map germ $f(x,y)$ with ∞ -jet (C_4^*) is finitely determined, then $t < \infty$.

PROOF. Suppose that $t = \infty$ i.e. $f(x,y) = (x, x^2y + \sum_{r \geq s} a_r xy^{r-1})$. Then for any positive integer k , $(0, y^k) \notin \text{tf}(\theta(n)) + \text{wf}(\theta(p))$. From Mather's theorem reviewed in §1, $f(x,y)$ is not finitely determined. This completes the proof.

For the rest of paper we assume that $t < \infty$. We identify a C^∞ -map germ $f(x,y)$ with a formal mapping (C_4^*) , but there will be no fear to confuse.

THEOREM 4.8. For a C^∞ -map germ $f(x,y)$ with ∞ -jet (C_4^*) the following holds.

- (1) If $s > t$, then $f(x,y)$ is C^0 - t -determined.
- (2) In the case that $2(s-2) < t-1$, the topological picture of $f(x,y)$ is given by Figure 9: \sim Figure 13.

PROOF. The set $f^{-1}(\{y=0\})$ is given by

$$\{y=0\} \cup \left\{ x^2 + \sum_{r \geq s} a_r xy^{r-2} + \sum_{r \geq t} b_r y^{r-1} = 0 \right\}$$

$$= \{y=0\} \cup \left\{ x = (1/2) \left\{ - \left(\sum_{r \geq s} a_r y^{r-2} \right) \pm \sqrt{\left(\sum_{r \geq s} a_r y^{r-2} \right)^2 - 4 \left(\sum_{r \geq t} b_r y^{r-1} \right)} \right\} \right\}.$$

We set

$$h(y) = \sum_{r \geq s} a_r y^{r-2}$$

$$\Delta_1(y) = \left(\sum_{r \geq s} a_r y^{r-2} \right)^2 - 4 \left(\sum_{r \geq t} b_r y^{r-1} \right).$$

The singular set $S(f)$ of $f(x,y)$ is given by

$$\left\{ x^2 + \sum_{r \geq s} (r-1) a_r y^{r-2} x + \sum_{r \geq t} r b_r y^{r-1} = 0 \right\}$$

$$= \left\{ x = (1/2) \left\{ - \left(\sum_{r \geq s} (r-1) a_r y^{r-2} \right) \pm \sqrt{\left(\sum_{r \geq s} (r-1) a_r y^{r-2} \right)^2 - 4 \left(\sum_{r \geq t} r b_r y^{r-1} \right)} \right\} \right\}$$

We set

$$\Delta_2(y) = \left(\sum_{r \geq s} (r-1) a_r y^{r-2} \right)^2 - 4 \left(\sum_{r \geq t} r b_r y^{r-1} \right).$$

(1) In the case $s > t$, from $s \geq 3$ we have that $2(s-2) > t-1$. Thus

$$\Delta_1(y) = -4b_t y^{t-1} + \text{higher terms},$$

$$\Delta_2(y) = -4tb_t y^{t-1} + \text{higher terms}.$$

(a) If t is odd and $b_t > 0$, then $\Delta_1(y) < 0$ and $\Delta_2(y) < 0$ for small $y \neq 0$. Thus $f^{-1}(\{y=0\}) = \{y=0\}$ and $f(x,y)$ has an isolated singularity at the origin. Hence $f(x,y)$ is a topological embedding and C^0 - t -determined. If t is odd and $b_t < 0$, then $\Delta_1(y) > 0$ and $\Delta_2(y) > 0$ for small $y \neq 0$.

Moreover,

$$f^{-1}(\{y=0\}) = \{y=0\} \cup \left\{ x = \pm \sqrt{-4b_t} y^{(t-1)/2} + \text{higher terms} \right\}$$

and

$$S(f) = \left\{ x = \pm \sqrt{-4tb_t} y^{(t-1)/2} + \text{higher terms} \right\}.$$

Thus the topological picture of $f(x,y)$ is given by Figure 7.

C^0 - t -determinacy of $f(x,y)$ is obvious from the figure. In the below figures we denote by thick lines the set $f^{-1}(\{y=0\})$ and

by dotted lines the singular set $S(f)$.

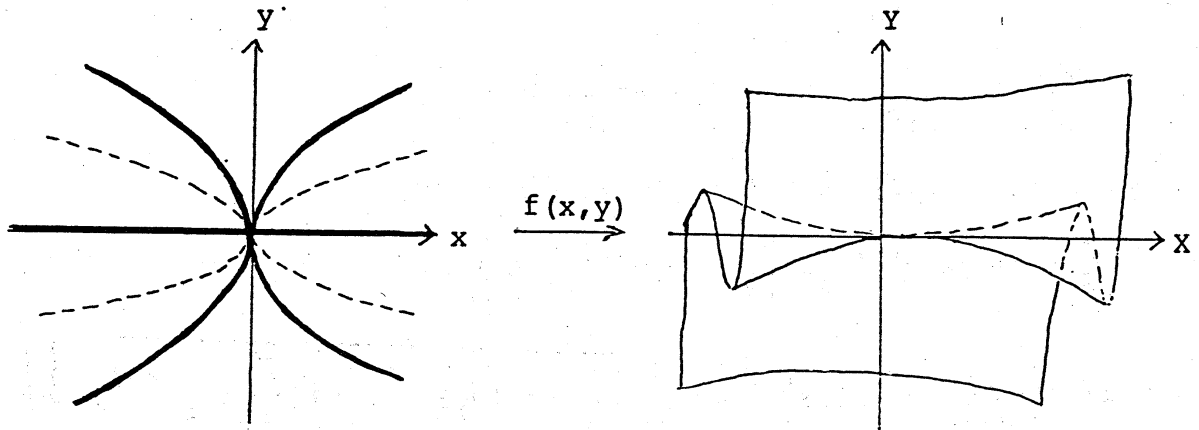

Figure 7.

(b) If t is even and $b_t > 0$, then $\Delta_1(y) > 0$ and $-\Delta_2(y) > 0$ for small $y < 0$. In the same way as above we obtain the topological picture of $f(x, y)$ which is given by Figure 8. The case where t is even and $b_t < 0$ can be reduced to the case $b_t > 0$ by the transformations of coordinates $(x, y) \rightarrow (x, -y)$ and $(X, Y) \rightarrow (X, -Y)$. From Figure 8 it is obvious that $f(x, y)$ is C^0 - t -determined.

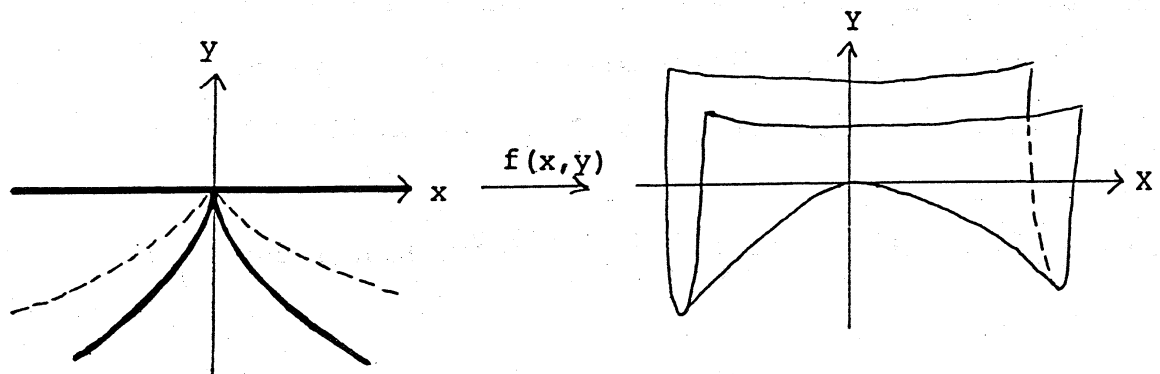

Figure 8.

(2) In the case $2(s-2) < t-1$, we have that for small $y \neq 0$

$$\Delta_1(y) = a_s^2 y^{2(s-2)} + \text{higher terms} > 0,$$

$$\Delta_2(y) = (s-1)^2 a_s^2 y^{2(s-2)} + \text{higher terms} > 0.$$

By the transformations $(x,y) \rightarrow (-x,y)$ and $(X,Y) \rightarrow (-X,Y)$, without loss of generality we can assume that $a_s > 0$. We consider the following cases.

(a) s is even and t is odd.

(b) s is even and t is even.

(c) s is odd and t is odd.

(d) s is odd and t is even.

In the case (a), if $b_t > 0$ then $\sum_{r \geq t} b_r y^{r-1} > 0$ for small $y \neq 0$.

Hence $\sqrt{\Delta_1(y)} < |h(y)|$ and $-h(y) \pm \sqrt{\Delta_1(y)} < 0$ for small $y \neq 0$.

Note that the functions $x = -h(y)$ and $x = \sum_{r \geq t} b_r y^{r-1}$ are

topologically the same as the functions respectively $x = -a_s y^{s-2}$

and $x = b_t y^{t-1}$ (cf. [2]). Thus the functions $x = (1/2)(-h(y)$

$\pm \sqrt{\Delta_1(y)}$) are locally monotone functions for small $y \neq 0$.

We can determine the topological picture of the singular set $S(f)$

by the same argument as above. Hence we obtain the topological

picture of $f(x,y)$ which is given by Figure 9. In the below

figures the thick lines with +sign (resp. -sign) mean the set

$\{x = (1/2)(-h(y) + \sqrt{\Delta_1(y)})\}$ (resp. $\{x = (1/2)(-h(y) - \sqrt{\Delta_1(y)})\}$).

If $b_t < 0$ then $\sum_{r \geq t} b_r y^{r-1} < 0$ for small $y \neq 0$. Hence

$\sqrt{\Delta_1(y)} > |h(y)|$ and $-h(y) + \sqrt{\Delta_1(y)} > 0$ for small $y \neq 0$. Therefore

we obtain the topological picture of $f(x,y)$ which is given by

Figure 10.

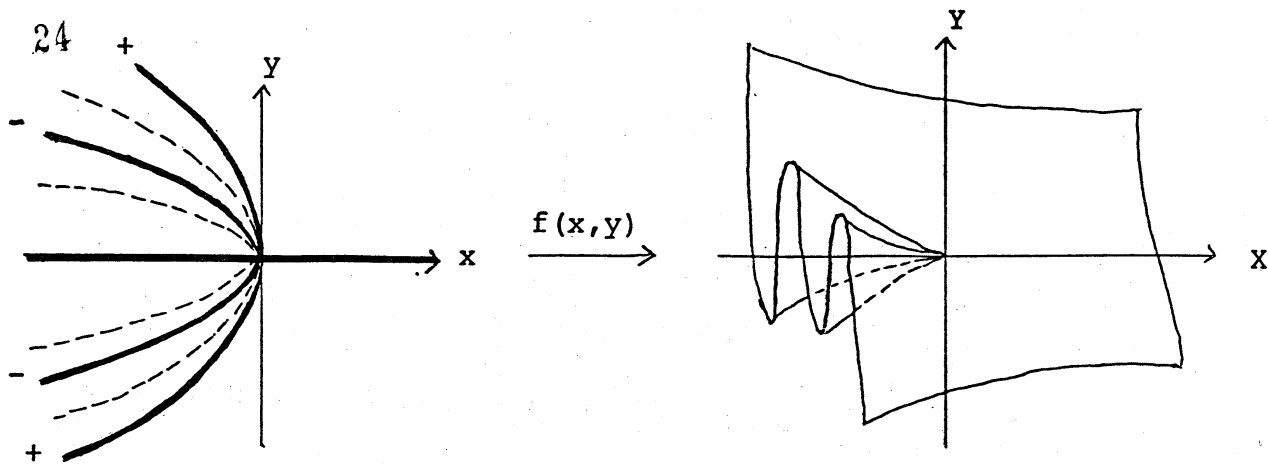

Figure 9.

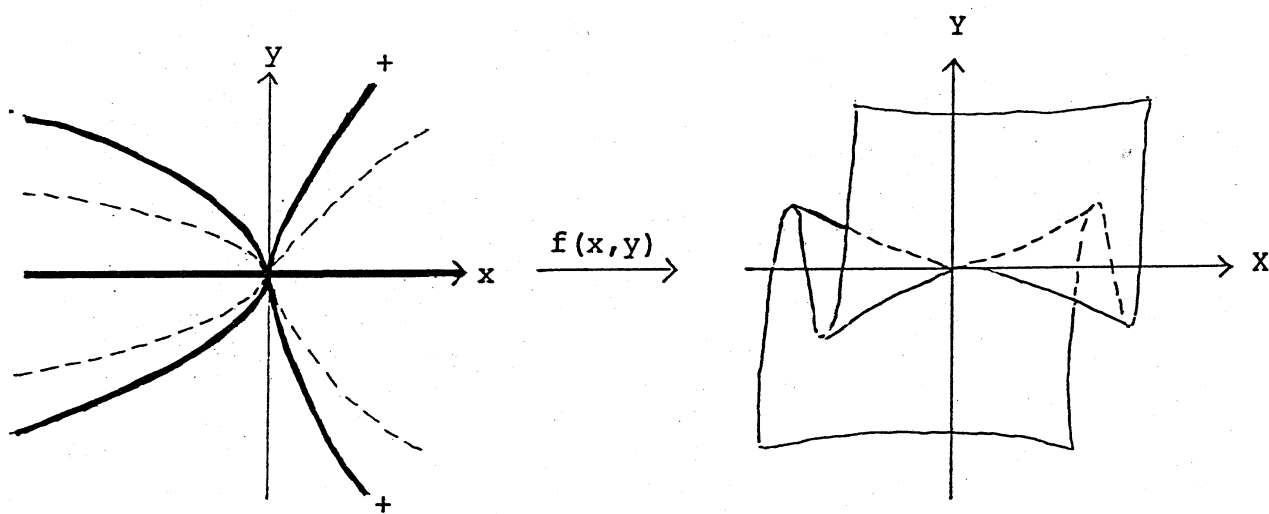

Figure 10.

In the case (b), if $b_t > 0$ then $\sum_{r \geq t} b_r y^{r-1} > 0$ for $y > 0$ and $\sum_{r \geq t} b_r y^{r-1} < 0$ for $y < 0$. Thus for small $y > 0$, $\sqrt{\Delta_1(y)} < |h(y)|$ and $-h(y) + \sqrt{\Delta_1(y)} < 0$. For small $y < 0$, $\sqrt{\Delta_1(y)} > |h(y)|$ and $-h(y) + \sqrt{\Delta_1(y)} > 0$. Therefore we obtain the topological picture of $f(x,y)$ which is given by Figure 11. The case $b_t < 0$ can be reduced to the case $b_t > 0$ by the transformations of coordinates such that $(x,y) \rightarrow (x,-y)$ and $(X,Y) \rightarrow (X,-Y)$.

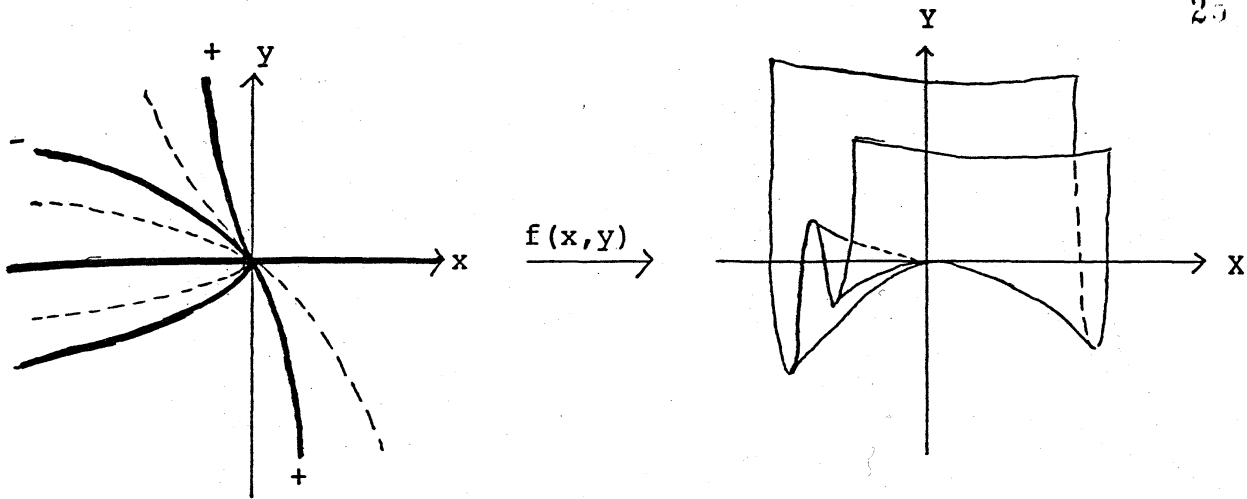

Figure 11.

In the case (c), if $b_t > 0$ then $\sum_{r=t} b_r y^{r-1} > 0$ for small $y \neq 0$.

Hence, $\sqrt{\Delta_1(y)} < |h(y)|$ and $-h(y) + \sqrt{\Delta_1(y)} < 0$ for small $y > 0$ and $-h(y) - \sqrt{\Delta_1(y)} > 0$ for small $y < 0$. From the facts that

$x = -h(y)$ and $x = \sum_{r=t} b_r y^{r-1}$ have the same topological types

as $x = -a_s y^{s-2}$ and $x = b_t y^{t-1}$, we obtain Figure 12. If $b_t < 0$,

then $\sum_{r=t} b_r y^{r-1} < 0$ for small $y \neq 0$. Hence $\sqrt{\Delta_1(y)} > |h(y)|$

and $-h(y) + \sqrt{\Delta_1(y)} > 0$ and $-h(y) - \sqrt{\Delta_1(y)} < 0$ for small $y \neq 0$.

Thus we obtain Figure 12'.

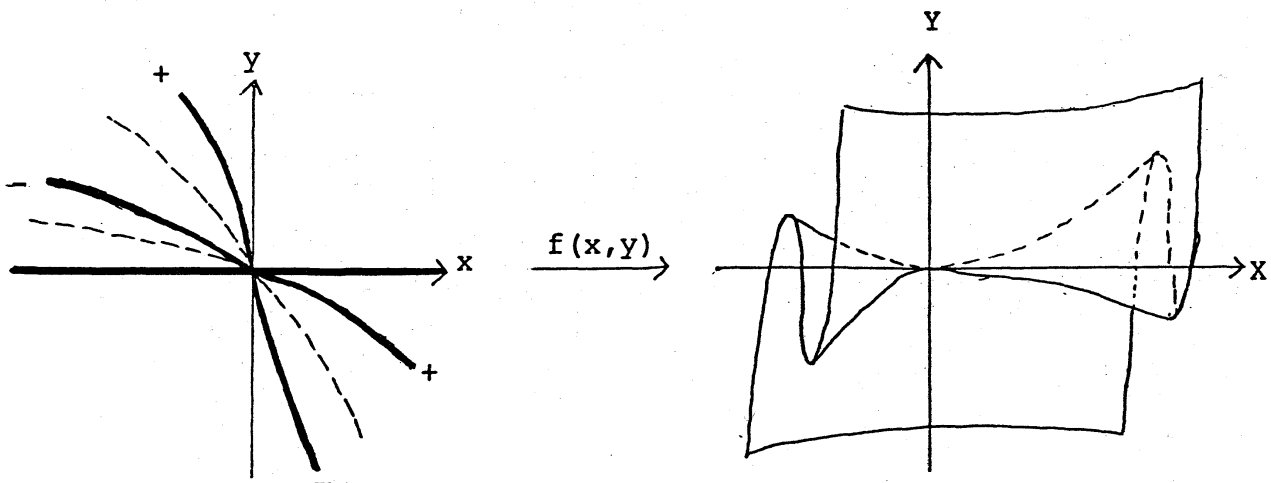

Figure 12.

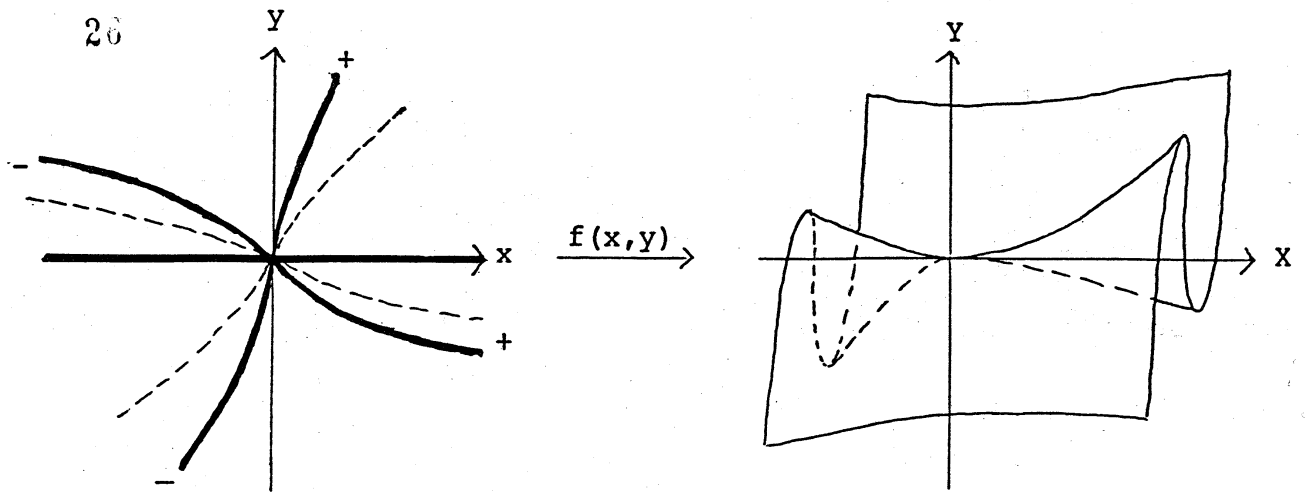

Figure 12'.

In the case (d), if $b_t > 0$ then $\sum_{r \geq t} b_r y^{r-1} > 0$ for $y > 0$

and $\sum_{r \geq t} b_r y^{r-1} < 0$ for $y < 0$. Thus for small $y > 0$, $\sqrt{\Delta_1(y)} <$

$|h(y)|$ and $-h(y) + \sqrt{\Delta_1(y)} < 0$. For small $y < 0$, $\sqrt{\Delta_1(y)} > |h(y)|$ and $-h(y) - \sqrt{\Delta_1(y)} < 0$. Therefore we obtain Figure 13. The case

$b_t < 0$ can be reduced to the case $b_t > 0$ by the transformations of coordinates such that $(x, y) \rightarrow (-x, -y)$ and $(X, Y) \rightarrow (-X, -Y)$. This completes the proof.

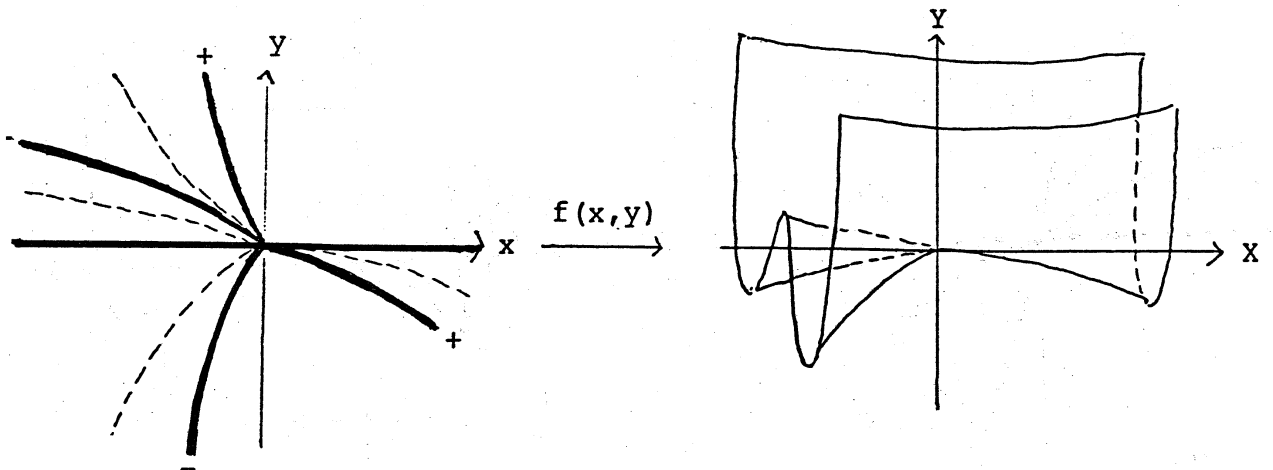

Figure 13.

References

- [1] A.A. du Plessis, On the determinacy of smooth map-germs, *Invent. Math.*, 58 (1980), 107-160.
- [2] T.C. Kuo, On C^0 -sufficiency of jets of potential functions, *Topology*, 8 (1969), 167-171.
- [3] T.C. Kuo, Characterizations of V -sufficiency of jets, *Topology*, 11 (1972), 115-131.
- [4] J. Mather, Stability of C^∞ -mappings III : finitely determined map-germs, *Publ. Math. I.H.E.S.*, 35 (1969), 127-156.
- [5] F. Takens, Singularities of vector fields, *Publ. Math. I.H.E.S.*, 43 (1973), 47-100.
- [6] C.T.C. Wall, Finite determinacy of smooth map-germs, *Bull. London Math. Soc.*, 13 (1981), 481-539.

Present Address:

DEPARTMENT OF MATHEMATICS

FACULTY OF SCIENCES

TOKYO METROPOLITAN UNIVERSITY

FUKAZAWA, SETAGAYA-KU TOKYO 158